



Smart Lighting. Sustainable Living

STREET LIGHTING

20million

STREET LIFE POINTS

More than
200,000
Smart Connected
Street Light Points

More than
1 MILLION
Street Light
Poles

More than
50,000
kms of
streets illuminated.

9 Decades
of
Legacy

 Inhouse
R&D and
Manufacturing
Facilities

 Concept
to
Care



BETTER LIFE

Brighter streets mean safer neighborhoods, vibrant communities, and enhanced quality of life. From bolstering public safety to fostering a sense of belonging, well-lit streets pave the way for improved social interactions and economic growth.

SAFER ROADS/ SECURE OUTDOORS

- Enhanced visibility for motorists and pedestrians reduce accidents making roads safer.
- Decreases antisocial acts, enhancing security for both public and private property.



EASY LIVABLE LIFE

Street lighting transforms the night, making every corner of our community inviting and accessible. With well-lit streets, evening strolls become serene, errands become effortless, and the sense of security blossoms.

It's not just about illumination; it's about crafting a lifestyle where ease and comfort intertwine with every step you take.

CITY BEAUTIFICATION

- Beyond just the functionality, street lights now have become an integral part of urban infrastructures aesthetics.
- Street lighting create more lively spaces at nights adding a charming ambiance to city streets, creating a welcoming atmosphere while enhancing the visual appeal of the cityscape.
- The city beams with pride, because of the glow of streetlights, it makes the city seem majestic and truly special.



LIGHT WITHOUT POLLUTION

There are growing concerns about light pollution and its impact on the night sky. Well designed Street lighting helps to minimize light pollution by directing light downward, minimizes glare, skyglow, clutter and light trespass to enhance the health of residents, reduce harm to the environment and to decrease energy consumption.

PROTECT ECOSYSTEM & WILDLIFE

- Reducing insect swarming nuisance
- Maintaining ecological balance
- Lowering cleaning costs for development authorities



LOWER TOTAL COST OF OWNERSHIP

Achieving optimized cost of ownership while adhering to aspects of safety & security is a challenge for every city manager. Well engineered Street lighting solutions with highest efficacy, precision optics, high durability and reliability can significantly contribute to bring down the overall cost of the installation.

FIT & FORGET

- Longer & maintenance free service life

COST OPTIMISATION

- Superior optics & design capabilities, helps reduction in overall project cost

HIGHER ENERGY SAVING

- Higher efficacy & precision optics ensures higher energy saving.

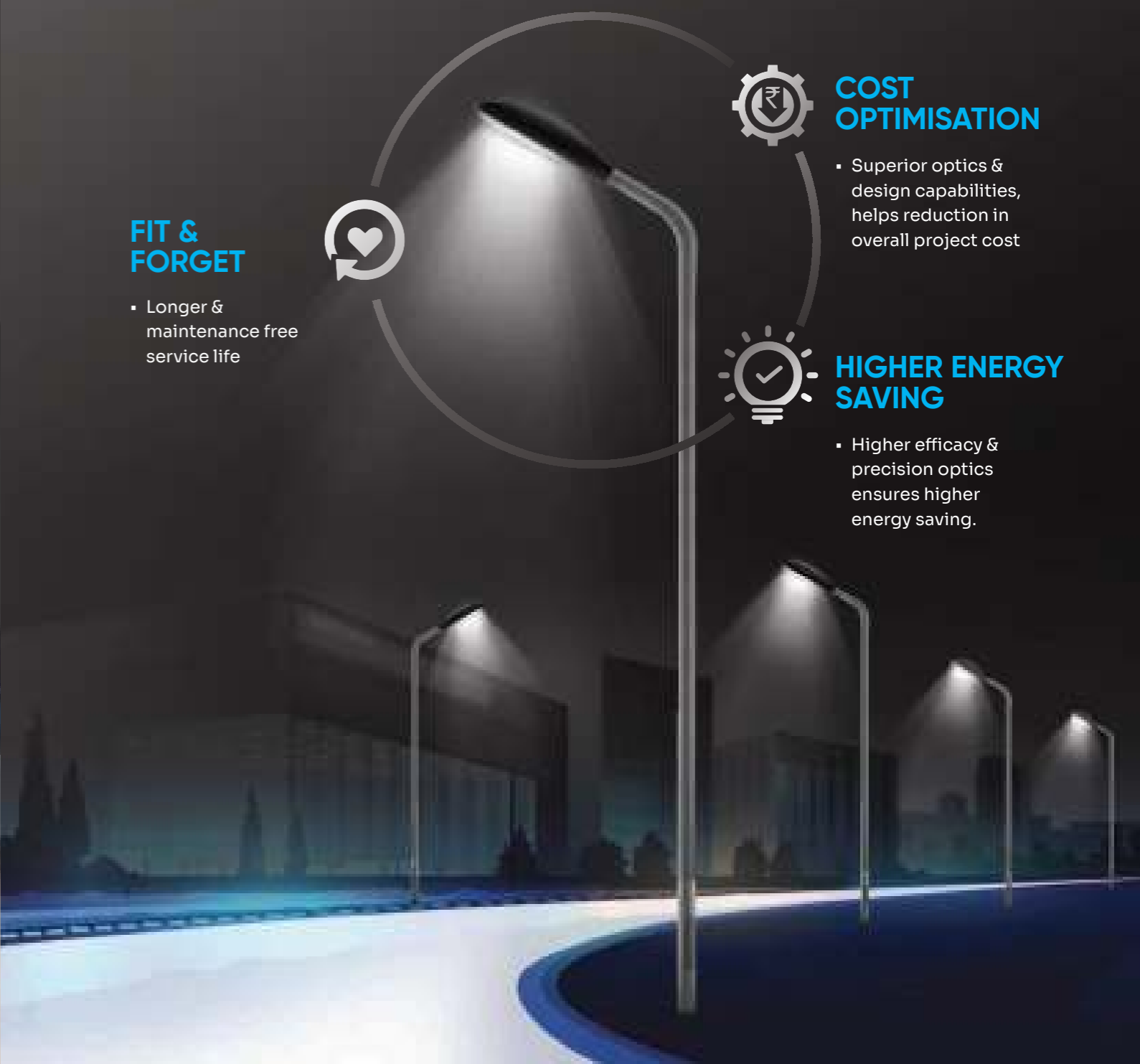

OUR PRODUCT DESIGN PHILOSOPHY

We create street lights that not only fulfill their primary function of illumination but also contribute positively to the urban environment in terms of energy efficiency, sustainability, aesthetics, safety, and inclusivity.



QUALITY OF LIGHT

Engineered for brilliance, our lights offer optimal brightness, clarity, and uniformity through precision optics tailor made for different types of roads ensuring safer & more inviting streets.

It also helps minimize light pollution while meeting standards like National Lighting Code (NLC) SP 72: 2010, Dark Sky Compliance, BUG Ratings.



HIGH ENERGY EFFICIENCY & LOW CARBON FOOTPRINT

Use of high efficacy LED chip combined with high quality electronics ensures maximum energy efficiency and low carbon footprint.



RELIABILITY & DURABILITY

Well engineered & robust construction of our street lights helps them withstand harsh weather conditions and environmental factors resulting in long-term savings by reducing the need for frequent replacements and repairs.



SMART & FUTURE READY

Our smart street lights provide enhanced control and comfort to city authorities. Their future-ready design ensures compatibility and integration with the latest solutions.



SUSTAINABLE

Use materials and manufacturing processes that minimize environmental impact. Recyclability, use of renewable resources, and reduction of carbon footprint throughout the product lifecycle. Additionally, prioritize longevity and durability to minimize maintenance requirements and extend the lifespan of street lights.

PATHWAY TO SMART LIVING THROUGH CONNECTIVITY





SMART LIGHTING MANAGEMENT SOLUTION

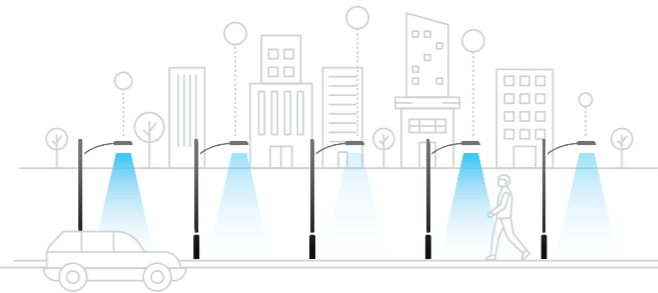

KEY FEATURES



Group Control



Group Dimming



Individual Control



Command Control Solutions



Technology - Agnostic Solutions

SOLUTION FEATURES

CitiSol offers various control options to its users which thereby have an impact on the experience of the end user – the citizens.



DIMMING PROFILE SETTING

Based on natural light conditions or traffic density on the road has never been smoother.

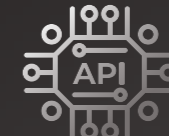

CENTRAL COMMAND CENTRE INTEGRATION

CitiSol provides full remote management for your entire lighting infrastructure. Open architecture and Open API allow secure integration to any of your preferred 3rd party application.



ON DEMAND

Let there be light when its needed the most, and that control needs to be executed at the click of a button. CitiSol has on demand, and near real time control of switching street lights on and off.



SCHEDULING

Keeping energy efficiency and maintenance efficiency as the uber goal of the platform solution, CitiSol assures schedule configuration as per customer needs.



ALERTS AND NOTIFICATIONS

CitiSol offers proactive and customizable notifications to help take time critical decisions. CitiSol is designed for the local asset management & maintenance crews, the Alerts tool offers near real-time status information of every individual or group of luminaires. Faults and outages are automatically registered, and notifications are sent to the assigned person to undertake action.



REPORTS AND CHARTS

The CitiSol platform has a central dashboard that helps you to track your city's lighting performance, status, energy consumption and savings over different locations and customizable periods of time. For example, grid voltage, current, power factor, can be tracked over a period. Device network analytics is also an integral part of this tool.

Solog

Smart Control Panels

ILLUMINATE YOUR CONTROL WITH BAJAJ CITISOL'S FEATURE BRILLIANCE

In the realm of street lighting, Bajaj CitiSol SoloG Group control panel stands tall as a cabinet-based solution tailored for the meticulous needs of road authorities, specifically medium to large municipalities and highway authorities. This robust system offers a reliable and efficient control mechanism for monitoring road and street-lights.



KEY FEATURES



Versatile
Compatibility



Connectivity
Options



Effortless
Deployment



Enterprise-Hosted
Software

Smart IoT RTU

Bajaj SoloG / ClusterG Cabinet Controller

Interfaces like the switch, the RS485 and the current are built in the RTU. External modules may be required based on a case-to-case basis.



1 To 3-phase Mains Input



Cabinet Door Monitoring



Mains Voltage Monitoring



Photocell Input



Integrated GPRS



**DISCOVER THE
RANGE OF
STREET LIGHTING
LUMINAIRES**



HEXO GRAND

Engineered Brilliance

Experience the epitome of state-of-the-art design and unparalleled performance with the Bajaj Hexo Grand high wattage LED streetlight. This exceptional lighting solution is tailor-made for prestigious applications such as National & State highways and Expressways elevating the overall safety and security.



Superior & appealing aesthetics

Epoxy powder coated pressure die-cast aluminium housing.



Best in Class System Efficacy

with upto 150 lumens per watt



Ease of maintenance

Specially designed clamps ensure Tool-less access to driver. Hinged back cover for easy maintenance.



Superior Optical Performance

with Non-yellowing polycarbonate secondary optics



Smart Ready

Provision for NEMA/ZHAGA adopter



IP66
IK08



4kV
Internal Surge
Protection -
10kV External SPD



THD<10%
PF>0.95



Tilt mounting flexibility at site

Applications:
Suitable for A1 Roads



Highway



Expressway

Product Diagram

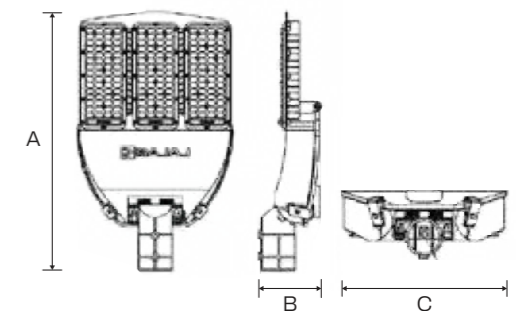

Polar Curves Specifications & Dimensions



| Wattages | Product Description | Voltage | CCT | System Current (Amp.) | Dimension A | Dimension B | Dimension C | Pole Dia Max (Ø) mm |
|----------|---------------------------|---------|-------|-----------------------|-------------|-------------|-------------|---------------------|
| 300W | HEXO P 435L WH HW PC SD G | 240 | 5700K | 1.32A | 600 | 137 | 345 | 65 |
| 350W | HEXO P 508L WH HW PC SG G | 240 | 5700K | 1.53A | 600 | 137 | 345 | 65 |





HEXO

The Highway champion

Hexo is a high performance street light for Highways with a dash of elegant design.



Superior & appealing aesthetics

Epoxy powder coated pressure die-cast aluminium housing with appealing aesthetics.



Best in Class System Efficacy

with upto 145 lumens per watt



Superior Optical Performance

with Non-yellowing polycarbonate secondary optics



High Performance Driver

Potted driver with inbuilt surge, voltage, open/short circuit protection for long & maintenance free service life.



IP66
IK08



4kV
Internal Surge
Protection -
10kV External SPD



THD<10%
PF>0.95

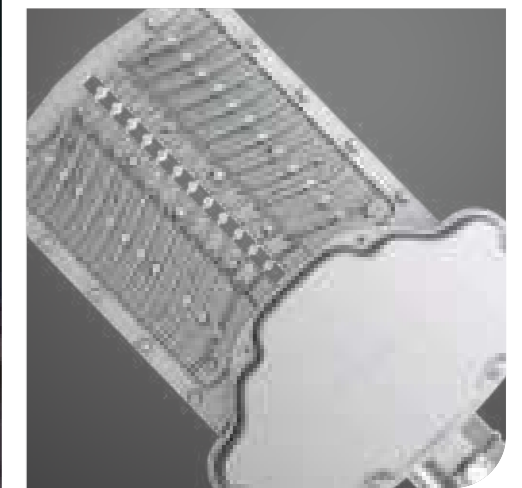

Applications:
Suitable for A1 & A2 Roads



Highway



Expressway

Product Diagram

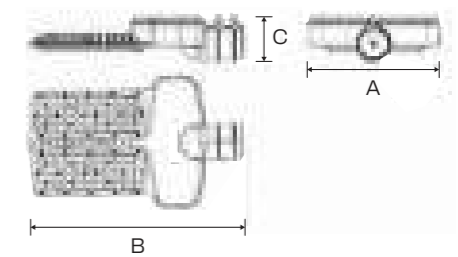

Polar Curves Specifications & Dimensions



| Wattages | Product Description | Voltage | CCT | System Current (Amp.) | Dimension | | | Pole Dia Max (Ø) mm |
|----------|---------------------------|---------|-------|-----------------------|-----------|-----|-----|---------------------|
| | | | | | A | B | C | |
| 150W | HEXO P 202L WH HW PC SD J | 240 | 5700K | 0.66A | 272 | 400 | 88 | 60 |
| 180W | HEXO P 243L WH HW PC SD J | 240 | 5700K | 0.79A | 272 | 400 | 88 | 60 |
| 210W | HEXO P 284L WH HW PC SD | 240 | 5700K | 0.90A | 296 | 482 | 100 | 60 |
| 250W | HEXO P 338L WH HW PC SD | 240 | 5700K | 1.1A | 296 | 482 | 100 | 60 |



EDGE NXT PC TG

Empowering Cities with Advanced Street Lighting Solutions

Crafted with precision & durability in mind, Edge NXT range ensures longevity and reliability even in the harshest conditions ensuring unparalleled clarity and brightness, illuminating roads with unmatched precision and visibility



Robust construction
Epoxy powder coated pressure die-cast aluminium housing



Best in Class System Efficacy
with upto 120 lumens per watt



Superior Optical Performance
LEDs are provided with non-yellowing secondary lens optics and toughened glass



High Performance Driver
Potted driver with inbuilt surge, voltage, open/short circuit protection for long & maintenance free service life.



IP66 IK07



4kV
Internal Surge Protection -
10kV External SPD



THD<10%
PF>0.95



Polar Curves

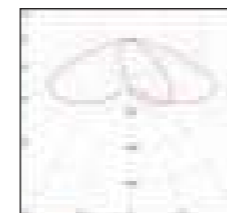

PO Optics

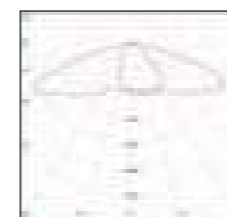

CR Optics

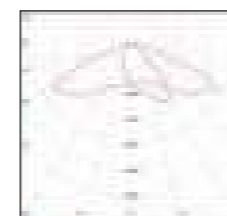

HW Optics

Applications: Suitable for A1 & A2 Roads



City Roads



Service Roads



Commercial Spaces

Product Diagram

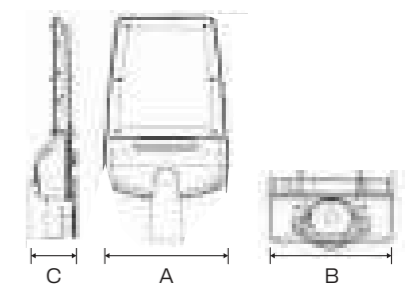

Specifications & Dimensions

| Wattages | Product Description | Voltage | CCT | System Current (Amp.) | Dimension | | | Pole Dia Max (Ø) mm |
|----------|-------------------------|---------|-------|-----------------------|-----------|-----|-----|---------------------|
| | | | | | A | B | C | |
| 90W | ENXT P 108L WH PO TG SD | 270 | 5700K | 0.39A | 448 | 255 | 96 | 60 |
| 120W | ENXT P 144L WH PO TG SD | 270 | 5700K | 0.52A | 448 | 255 | 96 | 60 |
| 150W | ENXT P 180L WH PO TG SD | 270 | 5700K | 0.65A | 448 | 255 | 96 | 60 |
| 210W | ENXT P 252L WH PO TG SD | 270 | 5700K | 0.90A | 548 | 306 | 115 | 60 |
| 250W | ENXT P 300L WH CR TG SD | 270 | 5700K | 1.07A | 548 | 306 | 115 | 65 |

Replace 'PO' with 'CR' in the product description for City Road optics

Replace 'PO' with 'HW' in the product description for Highway optics





EDGE NXT PC

Empowering Cities with Advanced Street Lighting Solutions

Crafted with precision & durability in mind, Edge NXT range ensures longevity and reliability even in the harshest city conditions. Our LEDs deliver unparalleled clarity and brightness, illuminating roads with unmatched precision and visibility

- 

Robust construction
Epoxy powder coated pressure die-cast aluminium housing
- 

Best in Class System Efficacy
with upto 120 lumens per watt
- 

Superior Optical Performance
LEDs are provided with non-yellowing secondary lens optics
- 

High Performance Driver
Potted driver with inbuilt surge, voltage, open/short circuit protection for long & maintenance free service life.



**IP66
IK08**



4kV
Internal Surge Protection -
10kV External SPD



THD<10%
PF>0.95



Applications: Suitable for B1 & B2 Roads

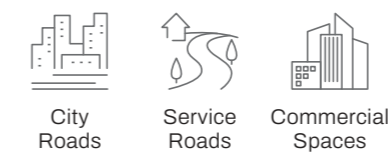

Product Diagram

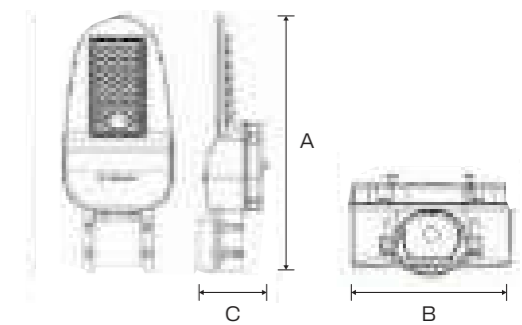

Polar Curves Specifications & Dimensions

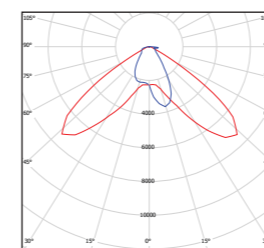

| Wattages | Product Description | Voltage | CCT | System Current (Amp.) | Dimension A | Dimension B | Dimension C | Pole Dia Max (Ø) mm |
|----------|------------------------|---------|-------|-----------------------|-------------|-------------|-------------|---------------------|
| 20W | ENXT P 20L WH PO PC SD | 270 | 5700K | 0.09A | 265 | 110 | 55 | 38 |
| 25W | ENXT P 25L WH PO PC SD | 270 | 5700K | 0.11A | 265 | 110 | 55 | 38 |
| 30W | ENXT P 30L WH PO PC SD | 270 | 5700K | 0.13A | 265 | 110 | 55 | 38 |
| 35W | ENXT P 35L WH PO PC SD | 270 | 5700K | 0.15A | 265 | 110 | 55 | 38 |
| 36W | ENXT P 36L WH PO PC SD | 270 | 5700K | 0.16A | 265 | 110 | 55 | 38 |
| 45W | ENXT P 54L WH PO PC SD | 270 | 5700K | 0.20A | 335 | 147 | 88 | 55 |
| 60W | ENXT P 72L WH PO PC SD | 270 | 5700K | 0.26A | 335 | 147 | 88 | 55 |
| 70W | ENXT P 84L WH PO PC SD | 270 | 5700K | 0.31A | 335 | 147 | 88 | 55 |

#External 10kV SPD available 45W and above



EDGE NXT-AON

Always ON street light

Bajaj Edge Nxt-AON is a battery Backup LED street light. In case of power failure, luminaire is provided with power supply backed up with battery which is inbuilt. It comes with Real Time Clock ensuring that the Luminaire will be functional from 6pm to 6am only. (timing is pre-set)



Robust Design
Epoxy powder coated pressure die-cast aluminium.



Best in Class System Efficacy
with upto 110 lumens per watt



High Performance Hybrid Driver
with built-in surge, over voltage, open/short circuit protection for longer service life



Battery In-built
4 hours battery backup



IP66
Ingress Protection



4kV
Internal Surge Protection -
10kV External SPD



THD<10%
PF>0.95

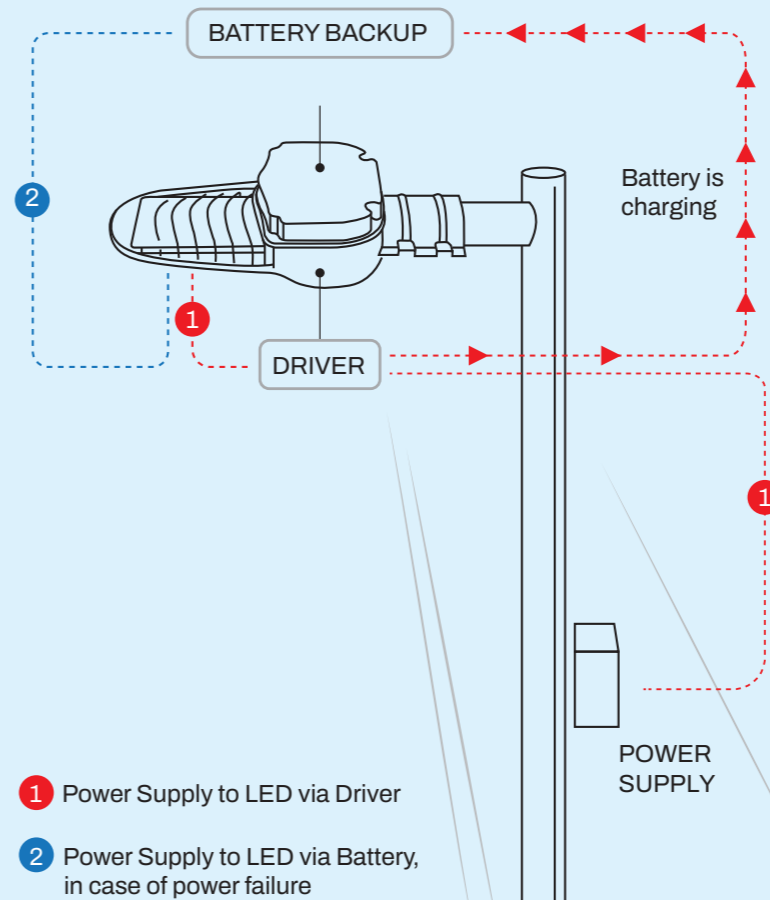

- 1 Power Supply to LED via Driver
- 2 Power Supply to LED via Battery, in case of power failure



Applications:
Suitable for B1 Roads



Service Roads



Commercial Spaces



Parks

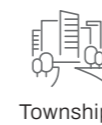

Townships

Product Diagram

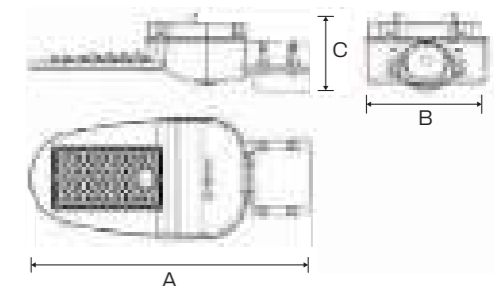

Polar Curves Specifications & Dimensions



| Wattages | Product Description | Voltage | CCT | System Current (Amp.) | Dimension | | | Pole Dia Max (Ø) mm |
|----------|-------------------------|---------|-------|-----------------------|-----------|-----|----|---------------------|
| | | | | | A | B | C | |
| 30W | ENXT P 30W WH PO PC INV | 240 | 5700K | 0.13A | 201 | 375 | 59 | 55 |



DOLPHIN

A cutting-edge street light

Introducing cutting-edge street lighting solutions designed to meet the demanding needs of modern urban environments. With external surge protection for added safety and top maintenance accessibility, our solutions redefine street lighting excellence.



Superior & appealing aesthetics

Unique & elegant design adds to the overall character of the space



Best in Class System Efficacy

with upto 120 lumens per watt



Superior Optical Performance

with non-yellowing secondary lens optics and toughened glass



High Performance Driver

Potted driver with inbuilt surge, voltage, open/short circuit protection for long & maintenance free service life.



IP66
IK07



4kV
Internal Surge
Protection -
10kV External SPD



THD<10%
PF>0.95



Applications:
Suitable for A2 & B2 Roads



City
Roads



Service
Roads



Commercial
Spaces

Product Diagram

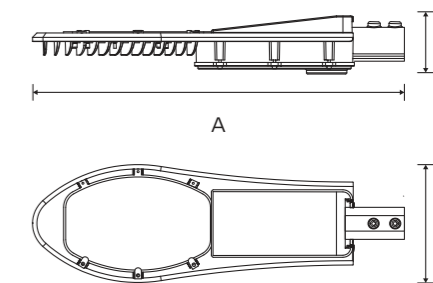

Polar Curves Specifications & Dimensions

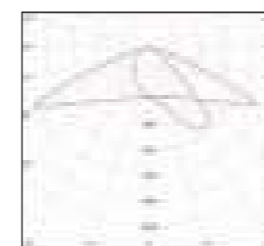

| Wattages | Product Description | Voltage | CCT | System Current (Amp.) | Dimension | | | Pole Dia Max (Ø) mm |
|----------|----------------------------|---------|-------|-----------------------|-----------|-----|----|---------------------|
| | | | | | A | B | C | |
| 90W | DOLPHIN P 90W WH HW TG SD | 270 | 5700K | 0.39A | 608 | 192 | 95 | 50 |
| 120W | DOLPHIN P 120W WH HW TG SD | 270 | 5700K | 0.52A | 608 | 192 | 95 | 50 |



ZELA

Optimum Performance

Zela is an aesthetic mid power street light range with robust construction & optimum performance.



Superior & appealing aesthetics

Pressure die-cast aluminium housing with sleek & aesthetic design



Best in Class System Efficacy

with upto 120 lumens per watt



Superior Optical Performance

with Non-yellowing polycarbonate secondary optics and toughened glass



High Performance Driver

Potted driver with inbuilt surge, voltage, open/short circuit protection for long & maintenance free service life.



**IP66
IK07**



4kV
Internal Surge
Protection -
10kV External SPD



THD<10%
PF>0.95

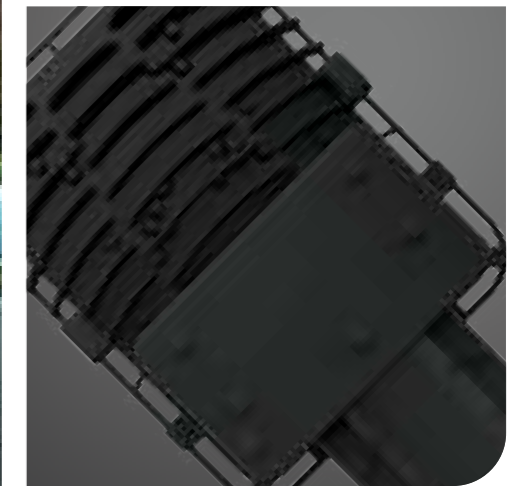

Applications: Suitable for A2 & B2 Roads



City
Roads



Service
Roads



Parks



Factory
Campus

Product Diagram

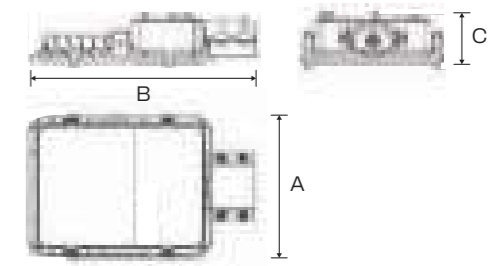

Polar Curves Specifications & Dimensions

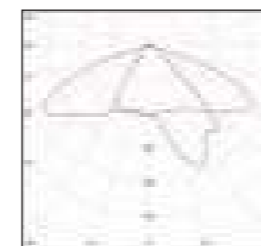

| Wattages | Product Description | Voltage | CCT | System Current (Amp.) | Dimension A | Dimension B | Dimension C | Pole Dia Max (Ø) mm |
|----------|------------------------|---------|-------|-----------------------|-------------|-------------|-------------|---------------------|
| 80W | ZELA P96L WH PO TG SD | 240 | 5700K | 0.34A | 188 | 298 | 70 | 55 |
| 90W | ZELA P108L WH PO TG SD | 240 | 5700K | 0.39A | 188 | 298 | 70 | 55 |
| 100W | ZELA P120L WH PO TG SD | 240 | 5700K | 0.44A | 188 | 298 | 70 | 55 |
| 120W | ZELA P144L WH PO TG SD | 240 | 5700K | 0.52A | 188 | 298 | 70 | 55 |





ZELA JAKE

Design and performance

Bajaj Zela Jake adds style, character and functionality to urban spaces. While street lights enhance public safety and security they has also establishe an artistic element of our urban landscape. Zela Jake comes to you as the perfect amalgamation of performance and aesthetics.



Superior & appealing aesthetics

Unique design provides a high aesthetic value and makes it more robust & durable



Best in Class System Efficacy

with upto 120 lumens per watt



Superior Optical Performance

with Non-yellowing polycarbonate secondary optics & toughened glass



Adjustable Mounting Clamp

makes installation easy for a variety of pole diameters



Higher Performance driver

Potted driver with inbuilt surge, voltage, open/short circuit protection for long & maintenance free service life.



IP66
IK07



4kV
Internal Surge
Protection -
10kV External SPD



THD<10%
PF>0.95



Applications: Suitable for A2 & B1 Roads



City Roads



Service Roads



Commercial Spaces



Parks



Factory Campus



Townships

Product Diagram

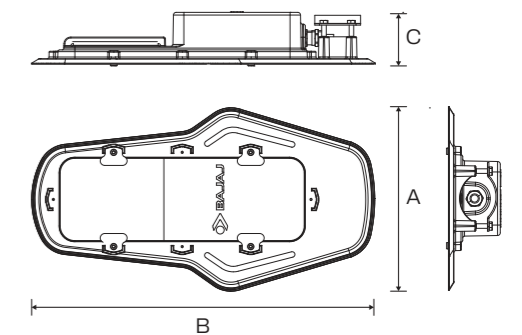

Polar Curves Specifications & Dimensions

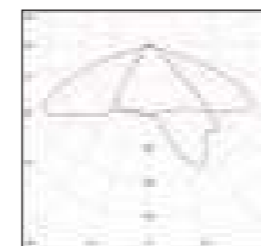

| Wattages | Product Description | Voltage | CCT | System Current (Amp.) | Dimension A | Dimension B | Dimension C | Pole Dia Max (Ø) mm |
|----------|--------------------------|---------|-------|-----------------------|-------------|-------------|-------------|---------------------|
| 45W | ZELA P 54L WH PO TG SD J | 240 | 5700K | 0.20A | 201 | 375 | 59 | 50 |
| 60W | ZELA P 72L WH PO TG SD J | 240 | 5700K | 0.26A | 201 | 375 | 59 | 50 |
| 72W | ZELA P 86L WH PO TG SD J | 240 | 5700K | 0.30A | 201 | 375 | 59 | 50 |



NEXO

A perfect urban companion

The Bajaj Nexo range caters to a wide range of low and mid-wattage applications providing flexibility & versatility in its usage, from illuminating campuses to lighting up city streets.

- 
Superior & appealing aesthetics
 Epoxy powder coated pressure die-cast aluminium housing.
- 
Best in Class System Efficacy
 with upto 120 lumens per watt
- 
Superior Optical Performance
 with Non-yellowing polycarbonate secondary optics
- 
High Performance Driver
 with built-in surge, over voltage, open/short circuit protection for longer service life



**IP66
IK08**



4kV
Internal Surge Protection -
#10kV External SPD



THD<10%
PF>0.90



Applications: Suitable for C, B2 & B1 Roads

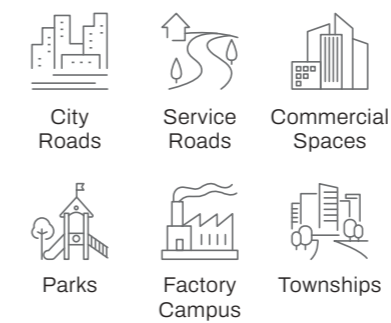

Product Diagram

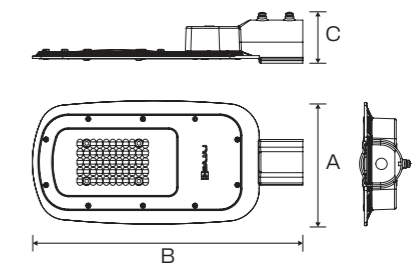

Specifications & Dimensions

| Wattages | Product Description | Voltage | CCT | System Current (Amp.) | Dimension A | Dimension B | Dimension C | Pole Dia Max D (Ø) mm |
|----------|-----------------------|---------|-------|-----------------------|-------------|-------------|-------------|-----------------------|
| 25W | NEXO 30L WH PO PC SD | 240 | 5700K | 0.07A | 117 | 260 | 48 | 42 40 |
| 30W | NEXO 36L WH PO PC SD | 240 | 5700K | 0.11A | 117 | 260 | 48 | 42 40 |
| 35W | NEXO 42L WH PO PC SD | 240 | 5700K | 0.15A | 136 | 298 | 51 | 42 40 |
| 45W | NEXO 54L WH PO PC SD | 240 | 5700K | 0.19A | 171 | 346 | 51 | 42 40 |
| 60W | NEXO 72L WH PO PC SD | 240 | 5700K | 0.26A | 171 | 346 | 51 | 42 40 |
| 70W | NEXO 84L WH PO PC SD | 240 | 5700K | 0.30A | 200 | 386 | 61 | 47 40 |
| 90W | NEXO 108L WH PO PC SD | 240 | 5700K | 0.39A | 200 | 386 | 61 | 47 45 |
| 100W | NEXO 120L WH PO PC SD | 240 | 5700K | 0.44A | 200 | 386 | 61 | 47 45 |
| 120W | NEXO 144L WH PO PC SD | 240 | 5700K | 0.52A | 200 | 386 | 61 | 47 45 |

#External 10kV SPD available 60W & above



ILLUMINATING NATION

From Panchayats, ULBs,
Municipal Corporations to
National Highways and
Expressways!!

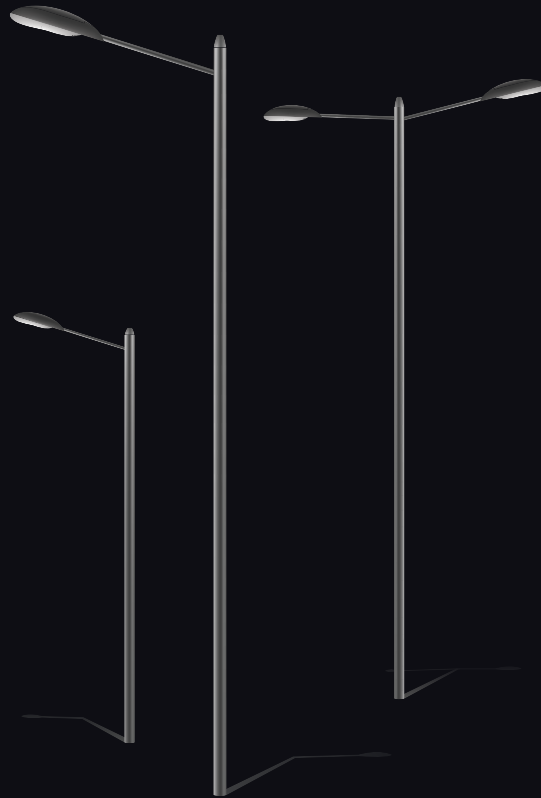

Electricals



27th Floor, One Unity Center (Erstwhile One International Center), Tower 4,
Senapati Bapat Marg, Prabhadevi (West), Mumbai – 400013 | Tel.: 022-2406 4400
Email: illumination@bajajelectricals.com | www.bajajelectricals.com

[f/BajajElecBiz](#) [x/BajajElecBiz](#) [@/bajajelecbiz](#) [in/BajajElectricals](#)

* Images of the products shown are for representation purpose only and the actual colour/size may vary.