

We touch
your **electricity**
everyday!

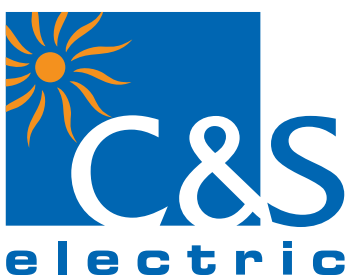

PRICE LIST

w.e.f 4th July, 2025

LV Components & Solutions

We touch your **electricity** everyday!



- Air Circuit Breakers
- Moulded Case Circuit Breakers
- Automatic Transfer Switch
- Motor Protection Circuit Breakers
- Power Contactors
- Control & Signalling Devices
- Meters
- Surge Protection Devices



INDUSTRIAL ELECTRICITY

- Air Circuit Breakers
- Moulded Case Circuit Breakers
- Power Contactors
- DC Energy Meters



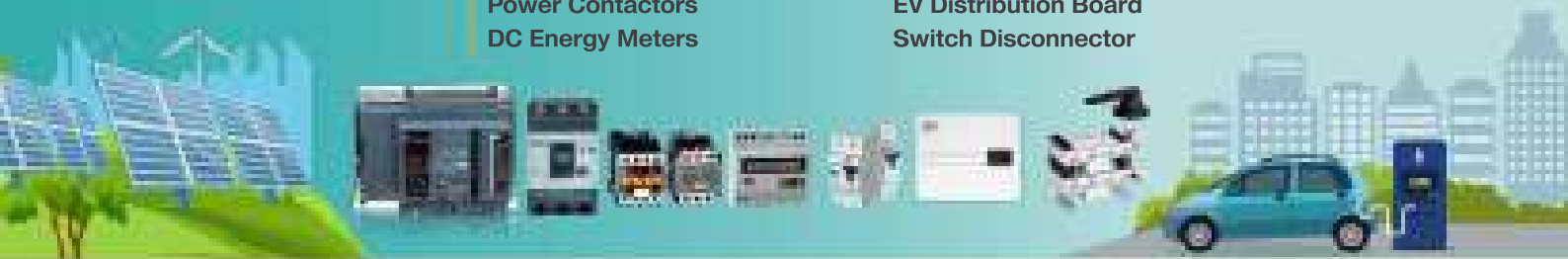

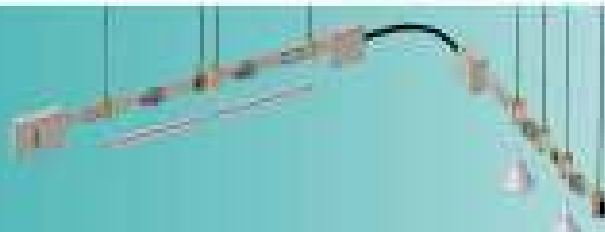

- Residual Current Circuit Breakers
- Miniature Circuit Breaker - DC & AC
- EV Distribution Board
- Switch Disconnecter



- Miniature Circuit Breakers
- Residual Current Circuit Breakers
- Distribution Boards
- RCBO
- Modular Switches



Lighting Trunking

Power Distribution Components	
WiNmaster3 ACB	6 ~ 10
WiNmaster2 ACB	11 ~ 14
AH/AHA ACB	15 ~ 23
WiNbreak1 MCCB	24 ~ 30
WiNbreak2 MCCB	31 ~ 34
WiNbreak MCCB - CSC Series	35
Switch Disconnecter Fuse Unit	36 ~ 38
Switch Disconnecter	39 ~ 41
On Load Changeover Switch	42
Bypass Switch	43 ~ 44
Switch Disconnecter Fuse Changeover	45
Automatic Transfer Switch	46 ~ 47
Fusegear	48 ~ 49
Lighting Trunking	50 ~ 51
Power Control Components	
Motor Protection Circuit Breaker (MPCB)	53 ~ 55
robusTa2 Contactor	56 ~ 57
Exceed M-Range Contactor	58 ~ 59
Exceed Contactor	60 ~ 61
robusTa Power Contactor	62 ~ 65
Capacitor Duty Contactor	66
robusTa Overload Relay	67
Accessories - robusTa & Exceed Contactor	68 ~ 69
D Range Contactor, Overload Relay & Accessories	70 ~ 71
4 Pole & 2 Pole Contactor & Overload Relay	72
Exceed Definite Purpose Contactor	73
Definite Purpose Contactor	74
Industrial Plug & Socket	75 ~ 76
Control & Signalling Device	77 ~ 85
Motor Starters	86 ~ 92
Protection, Measurement & Control Devices	
Surge Protection Device 	94
Meter 	95 ~ 96
Power Quality Device 	97 ~ 102
Electronic Overload Relay	103~105
Electronic Motor Protection Relay	106
ELR - Earth Leakage Relay	107
DG AMF / Synchronizing Controller	108
Voltage & Current Monitoring Relay & Timer	108
Temperature Sensor 	109
Final Power Distribution Components	
Miniature Circuit Breaker, Isolator & MCB Type Changeover Switch	111 ~ 118
RCBO	119 ~ 120
Residual Current Circuit Breaker	121 ~ 122
ACCL	123
EV - Distribution Board 	124
MIVAN - Distribution Board 	125
Distribution Board	126 ~ 131
Plug & Socket DB	132
Wiring Accessories	
Modular Switches - ELUSIO	134 ~ 135
Modular Switches - DIVINO	136 ~ 140
Weather Proof Enclosure - COMBI	141
Accessories	142
Modular Switches - PRIMO Plus	143 ~ 147
Modular Switches - PRIMO	148 ~ 150
Modular Switches - BRIDGG 	151 ~ 153
Type 2 Co-ordination Charts	154
Central Customer Care (CCC)	



General Terms & Conditions

Maximum Retail Price are subject to revision without prior notice and will be applicable as prevailing at the time of dispatch.

- This Price List supercedes all previous Price Lists.
- All prices are on Maximum Retail Price basis inclusive of all Duties, GST and any other Tax as applicable.
- All Prices are in Indian Rupees.
- All prices indicated are for unit quantity. In case of ordering products with standard packaging defined, Kindly multiply by unit rate.

WARRANTY CLAUSE

All our products carry a standard warranty against manufacturing defects for a period of 18 months from the date of invoicing or 12 months from the date of installation, whichever is earlier, subject to it's usages in normal recommended operating conditions. The Company's liability shall be limited to exchange or repair of the defective product sold, at its discretion, provided that such defective product are returned to nearest sales office. In the event of failure to return the defective product within 30 days to the location of origin of invoice, a debit note / invoice will be raised against the advance replacement material at the original supply price +5% penalty.

CENTRAL CUSTOMER CARE (CCC)

Single stop Customer Support for all service needs, please contact:

Toll Free Number: 1800 572 2012

E-mail: customercare@cselectric.co.in

POR - Price on request

Products have been classified as Stockable & Non Stockable items.

Non Stockable items has been marked as 

HSN Code denoted as below:

[HSN Code 8536] GST@18%*

[HSN Code 8537] GST@18%*

[HSN Code 8538] GST@18%*

*Subject to change as per Government of India notification

Power Distribution Components



- Air Circuit Breakers
- Moulded Case Circuit Breakers
- Switch Disconnecter Fuses
- Switch Disconnectors
- Changeover & Bypass Switches
- Automatic / Motorized Transfer Switches
- HRC Fuse Links, Fuse Bases & Fuse Holders

Efficient Partner in Power Distribution & Protection



 **RoHS**
Compliant

WiNmaster 3

Air Circuit Breaker

- Rated Operational Voltage upto 800V
- Breaking Capacity upto 100kA
- **Optimized Size** - Uniform Height & Depth across the Frame
- **Quick** - Fastest Opening & Closing Time
- **Truly Modular** - Front Accessible Accessories & SIC
- ***Universal Termination** - Terminal orientation convertible as Horizontal / Vertical on site
- No Derating upto 50 C
- Intelligent Micropro3 Release Family
- Multiple Parameter Measurement
- **Condition Monitoring** - Contact Wear Indication, 20 Trip History

INTELLIGENT RELEASE



Micropro Series

- LSIG; Neutral & Advance Protection
- MCR & HSISC Protection
- Thermal Memory for LT & ST
- LCD Display
- Self Diagnostics in Test Mode
- Modbus Protocol, ZSI and Breaker Failure Protection
- Contact wear Indication, Total no of Operations & Operating time
- ACB ID Assignment
- Bar Representation for Input Current and Voltage on Home Screen



WiNmaster3 Air Circuit Breakers - Operational Voltage upto 690V

- Range 630A to 4000A
- ACB with Universal Termination*
- Microprocessor release with Individual Fault Annunciation LEDs

Price on Request

[HSN Code: 8536]

3 Pole *MDO Winmaster3 Air Circuit Breakers with Micropro3- 3.1 Release with LSING Protection, Icu=Ics

Rating (Amps)	N (50kA @ 415V AC)	S (65kA @ 415V AC)	L (80kA @ 415V AC)	H (100kA @ 415V AC)
630A	WX306N3P1MDOA(S)	WX306S3P1MDOA(S)	WX306L3P1MDOA(S)	-
800A	WX308N3P1MDOA(S)	WX308S3P1MDOA(S)	WX308L3P1MDOA(S)	WX308H3P2MDOA(S)
1000A	WX310N3P1MDOA(S)	WX310S3P1MDOA(S)	WX310L3P1MDOA(S)	WX310H3P2MDOA(S)
1250A	WX312N3P1MDOA(S)	WX312S3P1MDOA(S)	WX312L3P1MDOA(S)	WX312H3P2MDOA(S)
1600A	-	WX316S3P1MDOA(S)	WX316L3P1MDOA(S)	WX316H3P2MDOA(S)
2000A	-	-	WX320L3P1MDOA(S)	WX320H3P2MDOA(S)
2500A	-	-	WX325L3P1MDOA(S)	WX325H3P2MDOA(S)
3200A	-	-	-	WX332H3P2MDOA(S)
4000A	-	-	-	WX340H3P2MDOA(S)

4 Pole *MDO Winmaster3 Air Circuit Breakers with Micropro3- 3.1 Release with LSING Protection, Icu=Ics

Rating (Amps)	N (50kA @ 415V AC)	S (65kA @ 415V AC)	L (80kA @ 415V AC)	H (100kA @ 415V AC)
630A	WX306N4P1MDOA(S)	WX306S4P1MDOA(S)	WX306L4P1MDOA(S)	-
800A	WX308N4P1MDOA(S)	WX308S4P1MDOA(S)	WX308L4P1MDOA(S)	WX308H4P2MDOA(S)
1000A	WX310N4P1MDOA(S)	WX310S4P1MDOA(S)	WX310L4P1MDOA(S)	WX310H4P2MDOA(S)
1250A	WX312N4P1MDOA(S)	WX312S4P1MDOA(S)	WX312L4P1MDOA(S)	WX312H4P2MDOA(S)
1600A	-	WX316S4P1MDOA(S)	WX316L4P1MDOA(S)	WX316H4P2MDOA(S)
2000A	-	-	WX320L4P1MDOA(S)	WX320H4P2MDOA(S)
2500A	-	-	WX325L4P1MDOA(S)	WX325H4P2MDOA(S)
3200A	-	-	-	WX332H4P2MDOA(S)
4000A	-	-	-	WX340H4P2MDOA(S)

3 Pole *MF Winmaster3 Air Circuit Breakers with Micropro3- 3.1 Release with LSING Protection, Icu=Ics

Rating (Amps)	N (50kA @ 415V AC)	S (65kA @ 415V AC)	L (80kA @ 415V AC)	H (100kA @ 415V AC)
630A	WX306N3P1MFA(S)	WX306S3P1MFA(S)	WX306L3P1MFA(S)	-
800A	WX308N3P1MFA(S)	WX308S3P1MFA(S)	WX308L3P1MFA(S)	WX308H3P2MFA(S)
1000A	WX310N3P1MFA(S)	WX310S3P1MFA(S)	WX310L3P1MFA(S)	WX310H3P2MFA(S)
1250A	WX312N3P1MFA(S)	WX312S3P1MFA(S)	WX312L3P1MFA(S)	WX312H3P2MFA(S)
1600A	-	WX316S3P1MFA(S)	WX316L3P1MFA(S)	WX316H3P2MFA(S)
2000A	-	-	WX320L3P1MFA(S)	WX320H3P2MFA(S)
2500A	-	-	WX325L3P1MFA(S)	WX325H3P2MFA(S)
3200A	-	-	-	WX332H3P2MFA(S)
4000A	-	-	-	WX340H3P2MFA(S)

4 Pole *MF Winmaster3 Air Circuit Breakers with Micropro3- 3.1 Release with LSING Protection, Icu=Ics

Rating (Amps)	N (50kA @ 415V AC)	S (65kA @ 415V AC)	L (80kA @ 415V AC)	H (100kA @ 415V AC)
630A	WX306N4P1MFA(S)	WX306S4P1MFA(S)	WX306L4P1MFA(S)	-
800A	WX308N4P1MFA(S)	WX308S4P1MFA(S)	WX308L4P1MFA(S)	WX308H4P2MFA(S)
1000A	WX310N4P1MFA(S)	WX310S4P1MFA(S)	WX310L4P1MFA(S)	WX310H4P2MFA(S)
1250A	WX312N4P1MFA(S)	WX312S4P1MFA(S)	WX312L4P1MFA(S)	WX312H4P2MFA(S)
1600A	-	WX316S4P1MFA(S)	WX316L4P1MFA(S)	WX316H4P2MFA(S)
2000A	-	-	WX320L4P1MFA(S)	WX320H4P2MFA(S)
2500A	-	-	WX325L4P1MFA(S)	WX325H4P2MFA(S)
3200A	-	-	-	WX332H4P2MFA(S)
4000A	-	-	-	WX340H4P2MFA(S)

NOTE:

*Universal termination option available upto 3200A

For ordering EDO ACB replace MDO by EDO in the above reference code.

For ordering EF ACB replace MF by EF in the above reference code.



Air Circuit Breaker

Winmaster3 Air Circuit Breakers - Operational Voltage 800V

- Range 630A to 4000A
- ACB with Universal Termination*
- Microprocessor release with Individual Fault Annunciation LEDs

Price on Request

[HSN Code: 8536]

3 Pole MDO Winmaster3 Air Circuit Breakers with Micropro3- 3.1 Release with LSING Protection, Icu=Ics

Rating (Amps)	MC (42kA @ 800V AC)	NC (50kA @ 800V AC)
630A	WX306MC3P1MDOA(S)	-
800A	WX308MC3P1MDOA(S)	WX308NC3P2MDOA(S)
1000A	WX310MC3P1MDOA(S)	WX310NC3P2MDOA(S)
1250A	WX312MC3P1MDOA(S)	WX312NC3P2MDOA(S)
1600A	WX316MC3P1MDOA(S)	WX316NC3P2MDOA(S)
2000A	WX320MC3P1MDOA(S)	WX320NC3P2MDOA(S)
2500A	WX325MC3P1MDOA(S)	WX325NC3P2MDOA(S)
3200A	-	WX332NC3P2MDOA(S)
4000A	-	WX340NC3P2MDOA(S)

4 Pole MDO Winmaster3 Air Circuit Breakers with Micropro3- 3.1 Release with LSING Protection, Icu=Ics

Rating (Amps)	MC (42kA @ 800V AC)	NC (50kA @ 800V AC)
630A	WX306MC4P1MDOA(S)	-
800A	WX308MC4P1MDOA(S)	WX308NC4P2MDOA(S)
1000A	WX310MC4P1MDOA(S)	WX310NC4P2MDOA(S)
1250A	WX312MC4P1MDOA(S)	WX312NC4P2MDOA(S)
1600A	WX316MC4P1MDOA(S)	WX316NC4P2MDOA(S)
2000A	WX320MC4P1MDOA(S)	WX320NC4P2MDOA(S)
2500A	WX325MC4P1MDOA(S)	WX325NC4P2MDOA(S)
3200A	-	WX332NC4P2MDOA(S)
4000A	-	WX340NC4P2MDOA(S)

3 Pole MF Winmaster3 Air Circuit Breakers with Micropro3- 3.1 Release with LSING Protection, Icu=Ics

Rating (Amps)	MC (42kA @ 800V AC)	NC (50kA @ 800V AC)
630A	WX306MC3P1MFA(S)	-
800A	WX308MC3P1MFA(S)	WX308NC3P2MFA(S)
1000A	WX310MC3P1MFA(S)	WX310NC3P2MFA(S)
1250A	WX312MC3P1MFA(S)	WX312NC3P2MFA(S)
1600A	WX316MC3P1MFA(S)	WX316NC3P2MFA(S)
2000A	WX320MC3P1MFA(S)	WX320NC3P2MFA(S)
2500A	WX325MC3P1MFA(S)	WX325NC3P2MFA(S)
3200A	-	WX332NC3P2MFA(S)
4000A	-	WX340NC3P2MFA(S)

4 Pole MF Winmaster3 Air Circuit Breakers with Micropro3- 3.1 Release with LSING Protection, Icu=Ics

Rating (Amps)	MC (42kA @ 800V AC)	NC (50kA @ 800V AC)
630A	WX306MC4P1MFA(S)	-
800A	WX308MC4P1MFA(S)	WX308NC4P2MFA(S)
1000A	WX310MC4P1MFA(S)	WX310NC4P2MFA(S)
1250A	WX312MC4P1MFA(S)	WX312NC4P2MFA(S)
1600A	WX316MC4P1MFA(S)	WX316NC4P2MFA(S)
2000A	WX320MC4P1MFA(S)	WX320NC4P2MFA(S)
2500A	WX325MC4P1MFA(S)	WX325NC4P2MFA(S)
3200A	-	WX332NC4P2MFA(S)
4000A	-	WX340NC4P2MFA(S)

MRP & Reference Code changes for ACB with Neutral CT MRP (₹)

For ACB with NCT add to the above price of 3 Pole ACB with MP3-3.1	ADD	10730
--	-----	-------

MRP & Reference Code changes as per the release modification Ordering Code MRP (₹)

Without release ACB	WR	POR
MicroPro3 3.1 (LSING)	A	
MicroPro3 4.1 (LSING, LED Display, Current Measurement, Trip History)	B	
MicroPro3 5.1 (LSING, 2 LED Display, Current + Voltage + Power Measurement, Trip History,	C	
MicroPro3 7.1 (LSING + Advanced Protections, LCD Display, Current + Voltage + Power + Harmonics Measurement, Trip History, ZSI, Communication, Maintenance Indicator)	D	

NOTE: For Winmaster3 MRP please connect with nearest branch office.

ACB Winmaster3 - Ordering Information

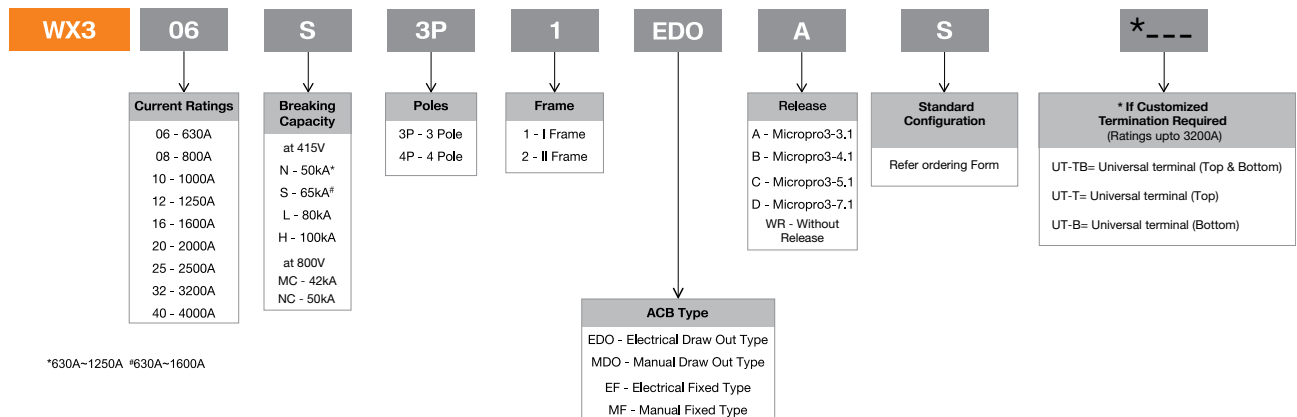



Winmaster3 ACB Order Form

Please fill separate sheet for each type of ACB, Tick the box in front of each appropriate item and fill in the blanks.

Customer Name	Order No. & Date	Delivery Date	End User/ Panel Builder Name & Ph. No.

Frame1 ACB	<input type="checkbox"/> 630A	<input type="checkbox"/> 1000A	<input type="checkbox"/> 1600A	<input type="checkbox"/> 2500A	Product Code
	<input type="checkbox"/> 800A	<input type="checkbox"/> 1250A	<input type="checkbox"/> 2000A		
Breaking Capacity	630A - 1250A		630A - 1600A		630A - 2500A
	<input type="checkbox"/> 50kA 415V / 36kA 690V		<input type="checkbox"/> 65kA 415V / 42kA 690V		<input type="checkbox"/> 80kA 415V / 50kA 690V <input type="checkbox"/> 42kA 800V

Frame2 ACB	<input type="checkbox"/> 800A	<input type="checkbox"/> 1250A	<input type="checkbox"/> 2000A	<input type="checkbox"/> 3200A	Qty.
	<input type="checkbox"/> 1000A	<input type="checkbox"/> 1600A	<input type="checkbox"/> 2500A	<input type="checkbox"/> 4000A	
Breaking Capacity	<input type="checkbox"/> 100kA, 415V AC / 65kA 690V <input type="checkbox"/> 50kA, 800V AC				

Variant	<input type="checkbox"/> 3 Pole	<input type="checkbox"/> 4 Pole	<input type="checkbox"/> Manual	<input type="checkbox"/> Electrical	<input type="checkbox"/> Fixed	<input type="checkbox"/> Drawout
---------	---------------------------------	---------------------------------	---------------------------------	-------------------------------------	--------------------------------	----------------------------------

Standard Configuration	Manual Fixed (MF)	Electrical Fixed (EF)	Manual Drawn Out (MDO)	Electrical Drawn Out (EDO)
	Microprocessor Release	Microprocessor Release	Microprocessor Release	Microprocessor Release
	60 Ways SIC (6NO+6NC available on site)	60 Ways SIC (6NO+6NC available on site)	60 Ways SIC (6NO+6NC available on site)	60 Ways SIC (6NO+6NC available on site)
		Charging Motor		Charging Motor
		Shunt Release		Shunt Release
		Closing Coil		Closing Coil
		RTC & Spring charge indication		RTC & Spring charge indication

Customized Termination - 630A to 3200A (Termination of 4000A is vertical only)

- Top Universal Termination
- Bottom Universal Terminal
- Top Flat Terminal
- Bottom Flat Terminal
- Phase Barriers
(Mandatory in case of Horizontal orientation of terminal / busbar)

Note: In case of customized termination please confirm for Top and Bottom

Closing Coil

110V AC/DC	220V AC/DC	415V AC
24V DC	48V DC	

Shunt Trip Coil

110V AC/DC	220V AC/DC	415V AC
24V DC	48V DC	

Charging Motor

110V AC/DC	220V AC/DC	415V AC
------------	------------	---------

UVT

100-130V AC	220-250V AC	380-440V AC
110V DC	220V DC	
Without Time Delay		With Time Delay

Release	<input type="checkbox"/> MicroPro3-3.1	<input type="checkbox"/> MicroPro3-4.1	<input type="checkbox"/> MicroPro3-5.1	<input type="checkbox"/> MicroPro3-7.1*
	<input type="checkbox"/> Without Release			
#(Control Voltage)	<input type="checkbox"/> 220V AC	<input type="checkbox"/> 110-220V DC	<input type="checkbox"/> 415V AC	<input type="checkbox"/> 24V DC

<input type="checkbox"/> Door Interlock	<input type="checkbox"/> Mechanical Interlock Cable Type	<input type="checkbox"/> Mechanical Counter
<input type="checkbox"/> Key Interlock	<input type="checkbox"/> Electrical Position Indication	<input type="checkbox"/> Neutral CT
<input type="checkbox"/> 1 ACB	<input type="checkbox"/> IP 54 Protection (For Drawout ACB Only)	
<input type="checkbox"/> 2 ACB	<input type="checkbox"/> Spring charge Ind.(Elec. Only)	
<input type="checkbox"/> 3 ACB		

Special Requirement if any

Notes:

- (1) Please refer to catalogue / Price list for further details of MicroPro3 release
- (2) Neutral CT is required along with Micropro3 release in case ground fault protection is required with 3P ACB and needs to be connected with solid Neutral Link.
- (3) Trip indication switch shall be available by default with ACB equipped with microprocessor release.

*Only for 220V AC



WiNmaster2

Breaker with intelligence

WiNmaster2 Power Circuit Breakers are a new generation of Air Circuit Breakers having modular construction to offer a truly global product platform meeting IEC, ANSI and UL standards.



 **RoHS**
Compliant

Range

630A~2500A

Single frame
for
complete
range

Poles

3P & 4P

Versions

Fixed & Drawout
(Mechanical
& Electrical)

$I_{cs}=I_{cu}=I_{cw}$
(for 1 sec)
at 50kA

Intelligent releases

Micropro2 3.1

Micropro2 4.1

Micropro2 7.1

Measurement

Trip
History

ZSI

Fault
LED retention

Short Circuit
Protection

Communication

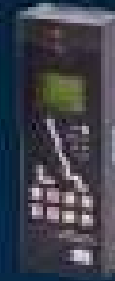
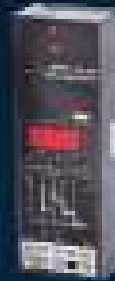



Air Circuit Breaker

WiNmaster2 Air Circuit Breaker

630A-2500A

Features:

- LSING Protection
- Digital Display
- Communication through RS 485 Port
- True RMS Sensing
- Current, Voltage, Power Measurement with Maximeter
- Thermal Memory
- Trip History
- Fault Indication
- Zone Selectivity
- Harmonics



WiNmaster2 Breakers fitted with standard accessories, tabulated below, are included in the Prices mentioned in subsequent tables.

Manual Fixed (MF)	Electrical Fixed (EF)	Manual Drawout (MDO)	Electrical Drawout (EDO)
<ul style="list-style-type: none"> - Microprocessor Release - Auxiliary Switch 6NO+6NC - Main CTs - Terminal Type - Horizontal 	<ul style="list-style-type: none"> - Microprocessor Release - Auxiliary Switch 6NO+6NC - Main CTs - AC/DC Charging Motor - Closing Coil - Shunt Trip - Terminal Type - Horizontal 	<ul style="list-style-type: none"> - Microprocessor Release - Auxiliary Switch 6NO+6NC - Main CTs - Safety Shutter - 60 Way auxiliary isolating contacts - Terminal Type - Horizontal 	<ul style="list-style-type: none"> - Microprocessor Release - Auxiliary Switch 6NO+6NC - Main CTs - Safety Shutter - 60 Way auxiliary isolating contacts - AC/DC Charging Motor - Closing Coil - Shunt Trip - Terminal Type - Horizontal

Air Circuit Breaker with Intelligent Release Micropro2-3.1

Fixed 3 Pole			[HSN Code: 8536]	
Rating (Amps)	Breaking Capacity Icu=Ics=Icw (1sec)	Reference	MRP (₹)	
			*MF	*EF
630	50kA	WX06N3P*A(S)	197150	263820
800	50kA	WX08N3P*A(S)	197150	263820
1000	50kA	WX10N3P*A(S)	207550	276970
1250	50kA	WX12N3P*A(S)	240850	311240
1600	50kA	WX16N3P*A(S)	269930	337990
2000	50kA	WX20N3P*A(S)	317020	384450
2500	50kA	WX25N3P*A(S)	355080	436460

Air Circuit Breaker with Intelligent Release Micropro2-3.1

Fixed 4 Pole			[HSN Code: 8536]	
Rating (Amps)	Breaking Capacity Icu=Ics=Icw (1sec)	Reference	MRP (₹)	
			*MF	*EF
630	50kA	WX06N4P*A(S)	248270	313800
800	50kA	WX08N4P*A(S)	248270	313800
1000	50kA	WX10N4P*A(S)	259270	325380
1250	50kA	WX12N4P*A(S)	303830	371880
1600	50kA	WX16N4P*A(S)	345600	413010
2000	50kA	WX20N4P*A(S)	414340	486370
2500	50kA	WX25N4P*A(S)	439190	510700

Drawout 3 Pole			[HSN Code: 8536]	
Rating (Amps)	Breaking Capacity Icu=Ics=Icw (1sec)	Reference	MRP (₹)	
			*MDO	*EDO
630	50kA	WX06N3P*A(S)	274280	333500
800	50kA	WX08N3P*A(S)	274280	333500
1000	50kA	WX10N3P*A(S)	285500	346850
1250	50kA	WX12N3P*A(S)	308960	378310
1600	50kA	WX16N3P*A(S)	354440	420510
2000	50kA	WX20N3P*A(S)	433220	502560
2500	50kA	WX25N3P*A(S)	530570	604930

Drawout 4 Pole			[HSN Code: 8536]	
Rating (Amps)	Breaking Capacity Icu=Ics=Icw (1sec)	Reference	MRP (₹)	
			*MDO	*EDO
630	50kA	WX06N4P*A(S)	325450	393400
800	50kA	WX08N4P*A(S)	325450	397150
1000	50kA	WX10N4P*A(S)	344090	412820
1250	50kA	WX12N4P*A(S)	366740	454050
1600	50kA	WX16N4P*A(S)	424470	493200
2000	50kA	WX20N4P*A(S)	522080	590130
2500	50kA	WX25N4P*A(S)	620390	686510

List Price & Reference Code changes for ACB with Neutral CT

For ACB with NCT add to the above price of 3 Pole ACB with MP2 3.1		ADD	10460
With NCT ordering Code will be	Existing Code	New Code	
	WX06N3PMFA(S)	WX06N3PNMFA(S)	
	WX06N3PNEFA(S)	WX06N3PNEFA(S)	
	WX06N3PNEDOA(S)	WX06N3PNEDOA(S)	
	WX06N3PNMDOA(S)	WX06N3PNMDOA(S)	

#Price Changes for ACB with high end release w.r.t MicroPro2 3.1 ACB

Release	Description	MRP (₹)	Ordering Code
MicroPro2 3.1	LSIG	As mentioned above in Reference	A
MicroPro2 4.1	LSING, Thermal Memory, Last Fault Trip History & current display	Add 7310	B
MicroPro2 7.1	LSING, Earth Leakage Protection, Trip History, Over & under voltage/ Frequency, voltage imbalance, current imbalance, Reverse power, Phase Sequence, Leakage Alarm, Current imbalance Protection, Fault Indication, current, voltage and power display with maximeter feature with inbuilt communication	Add 54900	C
Without Release	For ordering ACB without release (Reduce from MRP of ACB with Micropro2 - 3.1 release)	Reduce 6660	WR

NOTES:

- 1) While ordering an ACB, the complete catalogue reference by replacing '*' with ACB type: MF-Manual Fixed, EF-Electrical Fixed, MDO-Manual Drawout, EDO-Electrical Drawout
- 2) In TP ACB, if earth fault facility required. Please add Price of neutral CT to ACB Price as mentioned above.
- 3) Other options of terminals are available on request.
- 4) #For ordering replace A with B or C, as per requirement.
- 5) All configurable products are non stockable.



WiNmaster2/3 Air Circuit Breaker Accessories

Main Accessories (Please specify ACB rating & type while placing order)

1. Under Voltage Trip Device [HSN Code: 8538]

Sl. No.	Compatible with	Description	Reference	MRP (₹)
1.1	WM2/ WM3	Without Delay Common for 630A~4000A	CS-WM2-AUH-V-ABC-**	10220
1.2	WM2/ WM3	With Delay Common for 630A~4000A	CS-WM2-AUH-D-ABC-**	11170

2. Continuous rated Shunt Trip and Closing Coil [HSN Code: 8538]

Sl. No.	Compatible with	Description	Reference	MRP (₹)
2.1	WM2/ WM3	Shunt Coil Common for 630A~4000A	CS-WM2-AVH-SC-ABC-**	5110
2.2	WM2/ WM3	Closing Coil Common for 630A~4000A	CS-WM2-AVH-CC-ABC-**	5110

3. Accessories [HSN Code: 8538]

Sl. No.	Compatible with	Description	Reference	MRP (₹)
3.1	WM2 / WM3	Universal Charging Motor-Common for 630A-2500A (for 220VAC/DC)	CS-WM2-AMH-AV-A-M	45290
3.2	WM2 / WM3	Universal Charging Motor-Common for 630A-2500A (for 415VAC)	CS-WM2-AMH-AU-A1-N	45290
3.3	WM2 / WM3	Universal Charging Motor-Common for 630A-2500A (for 110VAC/DC)	CS-WM2-AMH-AS-A1-F	45290
3.4	WM3	Universal Charging Motor for Frame2, Common for 800A-4000A (for 220VAC/DC)	CS-WM3-AMH-AV-A2-M	45290
3.5	WM3	Universal Charging Motor for Frame2, Common for 800A-4000A (for 415VAC)	CS-WM3-AMH-AU-A2-N	45290
3.6	WM3	Universal Charging Motor for Frame2, Common for 800A-4000A (for 110VAC/DC)	CS-WM3-AMH-AS-A2-F	45290
3.7	WM2 / WM3	LIFTER	LIFTER (580x600)*	189910
			LIFTER-SPL (690x570)*	208800
3.8	WM2 / WM3	Mismatch Prevention Device	CS-WM2-MIP-AB	2040
3.9	WM2	Panel Door Interlock (Drawout)	CS-WM2-PDL-AB	2920
3.10	WM2 / WM3	Mechanical interlock for interlocking 2 ACBs (Drawout)	CS-WM2-MIL-HD	48100
3.11	WM2 / WM3	Mechanical interlock for interlocking 2 ACBs (Fixed)	CS-WM2-MIL-HF	41100
3.12	WM2 / WM3	Key Lock (1 Lock + 1 Key)	CS-WM2-AKI-AB	8220
3.13	WM2 / WM3	Key Lock (3 Lock + 2 Key)	CS-WM2-AKI-1-AB	8590
3.14	WM2 / WM3	Key Lock (2 Lock + 1 Key)	CS-WM2-AKI-2-AB	6560
3.15	WM2 / WM3	Mechanical operation counter	CS-WM2-ASC-ABC	3760
3.16	WM2 / WM3	Ready to close contact	CS-WM2-RTC-ABC	2040
3.17	WM2 / WM3	Phase Barrier - 3 Pole (Drawout)	CS-WM2-PB-3P	2580
3.18	WM2 / WM3	Phase Barrier - 4 Pole (Drawout)	CS-WM2-PB-4P	3620
3.19	WM2 / WM3	Mechanical Interlock for 1 to 3 ACBs-Drawout (Cable Interlock)	CS-WM2-MIL3-HD	57550
3.20	WM2 / WM3	Mechanical Interlock for 1 to 3 ACBs - Fixed (Cable Interlock)	CS-WM2-MIL3-HF	62290
3.21	WM2 / WM3	Panel Door Interlock (Fixed)	CS-WM2-PDLF-AB	2710
3.22	WM2 / WM3	Phase Barrier- 3Pole (Fixed)	CS-WM2-PBF-3P	2870
3.23	WM2 / WM3	Phase Barrier- 4Pole (Fixed)	CS-WM2-PBF-4P	4070
3.24	WM2 / WM3	Position Indication Switch	CS-WM2-ALB-AB	6100
3.25	WM2 / WM3	Auxiliary Switch (6NO+6NC)	CS-WM2-AXH-6A6B	5800
3.26	WM2 / WM3	IP54 cover for Drawout ACB- Frame-1	CS-WM3-CVRIP54-FR1	14320
3.27	WM3	IP54 cover for Drawout ACB- Frame-2	CS-WM3-CVRIP54-FR2	18250
3.28	WM3	Panel Door Lock (Drawout)	CS-WM3-DOOR-INT-DRAB	1250

* in (mm)

**Options for Coil Voltage

Description	AC Control Voltage			DC Control Voltage			
	110V	220-250V	380-440V	24V	48V	110V	220V
UVT	FA	MA	NA	-	-	FD	MD
Shunt & Closing Coil	100/130V AC/DC		220-250V AC/DC	380V AC	24V DC	28V DC	
	F		M	N	BD	ED	

NOTES: All configurable products are non stockable.

Air Circuit Breaker AH / AHA

Temperature Monitoring Protection



Extended Lifespan | Safety | Preventive Maintenance | Choice of Selection

INTELLIGENT RELEASE

The AH/ AHA series circuit breakers are robust circuit breakers complying to IEC 60947-2 & are equipped with unique 'Slow Close Operation of Contacts'. Equipped with smart features of advance Micropro*

Intelligent Protection Releases

- Power & Current Measurement
- Individual Fault Annunciation
- ZSI
- 100 Event Records
- Advance Protection
- SCADA Compatibility - RS485 Port
- Data Uploading to PC / Laptop through USB port





Air Circuit Breaker

Air Circuit Breaker AH / AHA

630A-6300A

(I) ACB with Intelligent Release MicroPro 3.1

Features:

- LSIG Protection
- True RMS Sensing
- Fault Indication

(For standard configuration, please refer AH / AHA ACB Order Form)



LT Air Circuit Breaker fitted with Intelligent Release MicroPro 3.1

Fixed 3 Pole [HSN Code: 8536]

Rating (Amps)	Breaking Capacity Icu=Ics=Icw (1sec)	Reference	MRP (₹)	
			*MF	*EF
630	50kA	AHA06N3P*MP3.1(S)	158530	217100
800	50kA	AHA08N3P*MP3.1(S)	158530	217100
1000	50kA	AHA10N3P*MP3.1(S)	164020	224760
1250	50kA	AHA12N3P*MP3.1(S)	196620	264970
1600	50kA	AHA16N3P*MP3.1(S)	207910	267160
2000	50kA	AHA20N3P*MP3.1(S)	256020	347800
2500	50kA	AHA25N3P*MP3.1(S)	308390	374790
3200	65kA	AH30DCSMP3.1*(S)	461670	541630
4000	85kA	AH40DCSMP3.1*(S)	743800	810190

Fixed 4 Pole [HSN Code: 8536]

Rating (Amps)	Breaking Capacity Icu=Ics=Icw (1sec)	Reference	MRP (₹)	
			*MF	*EF
630	50kA	AHA06N4P*MP3.1(S)	197810	255130
800	50kA	AHA08N4P*MP3.1(S)	197810	255130
1000	50kA	AHA10N4P*MP3.1(S)	202630	262980
1250	50kA	AHA12N4P*MP3.1(S)	246980	310810
1600	50kA	AHA16N4P*MP3.1(S)	282450	337420
2000	50kA	AHA20N4P*MP3.1(S)	338420	427330
2500	50kA	AHA25N4P*MP3.1(S)	385290	464300
3200	65kA	AH30D4CSMP3.1*(S)	612540	684970
4000	85kA	AH40D4CSMP3.1*(S)	887140	1013860

Drawout 3 Pole [HSN Code: 8536]

Rating (Amps)	Breaking Capacity Icu=Ics=Icw (1sec)	Reference	MRP (₹)	
			*MD	*ED
630	50kA	AHA06N3P*MP3.1(S)	240200	294870
800	50kA	AHA08N3P*MP3.1(S)	240200	294870
1000	50kA	AHA10N3P*MP3.1(S)	251500	306170
1250	50kA	AHA12N3P*MP3.1(S)	290590	337400
1600	50kA	AHA16N3P*MP3.1(S)	308810	379670
2000	50kA	AHA20N3P*MP3.1(S)	392300	450860
2500	50kA	AHA25N3P*MP3.1(S)	473890	532590
3200	65kA	AHA30S3P*MP3.1(S)	605890	664910
4000	65kA	AHA40S3P*MP3.1(S)	755200	796770
4000	85kA	AH40DCSMP3.1*(S)	786050	822260
5000	85kA	AH50CCSMP3.1*(S)	POR	POR
6300	100kA	AH60CCSMP3.1*(S)	POR	POR

Drawout 4 Pole [HSN Code: 8536]

Rating (Amps)	Breaking Capacity Icu=Ics=Icw (1sec)	Reference	MRP (₹)	
			*MD	*ED
630	50kA	AHA06N4P*MP3.1(S)	310720	371340
800	50kA	AHA08N4P*MP3.1(S)	310720	371340
1000	50kA	AHA10N4P*MP3.1(S)	317650	384480
1250	50kA	AHA12N4P*MP3.1(S)	374740	410510
1600	50kA	AHA16N4P*MP3.1(S)	401090	454710
2000	50kA	AHA20N4P*MP3.1(S)	509600	553630
2500	50kA	AHA25N4P*MP3.1(S)	598870	647030
3200	65kA	AHA30S4P*MP3.1(S)	705670	792530
4000	65kA	AHA40S4P*MP3.1(S)	1006570	1018610
4000	85kA	AH40D4CSMP3.1*(S)	1020410	1033730
5000	85kA	AH50C4CSMP3.1*(S)	POR	POR
6300	100kA	AH60C4CSMP3.1*(S)	POR	POR

NOTES: All configurable products are non stockable.



Air Circuit Breaker

Air Circuit Breaker AH / AHA

630A-6300A

(III) ACB with Thermal Magnetic Release

(For standard configuration, please refer AH / AHA ACB Order Form)

LT Air Circuit Breaker fitted with Thermal Magnetic Release and Standard Accessories, as applicable.

Fixed 3 Pole [HSN Code: 8536]

Rating (Amps)	Breaking Capacity Icu=Ics=Icw (1sec)	Reference	MRP (₹)	
			*MF	*EF
630	50kA	AHA06N3P*TM(S)	127450	177570
800	50kA	AHA08N3P*TM(S)	136560	197150
1000	50kA	AHA10N3P*TM(S)	139340	198320
1250	50kA	AHA12N3P*TM(S)	185560	241370
1600	50kA	AHA16N3P*TM(S)	192470	259070
2000	50kA	AHA20N3P*TM(S)	221070	308170
2500	50kA	AHA25N3P*TM(S)	247830	356390
3200	65kA	AH30DCSTM*(S)	414590	498230
4000	85kA	AH40DCSTM*(S)	642040	724610

Fixed 4 Pole [HSN Code: 8536]

Rating (Amps)	Breaking Capacity Icu=Ics=Icw (1sec)	Reference	MRP (₹)	
			*MF	*EF
630	50kA	AHA06N4P*TM(S)	170640	219750
800	50kA	AHA08N4P*TM(S)	181070	230490
1000	50kA	AHA10N4P*TM(S)	184240	240550
1250	50kA	AHA12N4P*TM(S)	230330	290610
1600	50kA	AHA16N4P*TM(S)	249450	318020
2000	50kA	AHA20N4P*TM(S)	302330	368840
2500	50kA	AHA25N4P*TM(S)	357260	423010
3200	65kA	AH30D4CSTM*(S)	518500	594630
4000	85kA	AH40D4CSTM*(S)	760450	881910

Drawout 3 Pole [HSN Code: 8536]

Rating (Amps)	Breaking Capacity Icu=Ics=Icw (1sec)	Reference	MRP (₹)	
			*MD	*ED
630	50kA	AHA06N3P*TM(S)	203470	262750
800	50kA	AHA08N3P*TM(S)	205680	270660
1000	50kA	AHA10N3P*TM(S)	211300	274080
1250	50kA	AHA12N3P*TM(S)	254880	309330
1600	50kA	AHA16N3P*TM(S)	294420	347050
2000	50kA	AHA20N3P*TM(S)	348370	399960
2500	50kA	AHA25N3P*TM(S)	420290	475280
3200	65kA	AHA30S3P*TM(S)	529550	585240
4000	65kA	AHA40S3P*TM(S)	701370	756010
4000	85kA	AH40DCSTM*(S)	736990	802240

Drawout 4 Pole [HSN Code: 8536]

Rating (Amps)	Breaking Capacity Icu=Ics=Icw (1sec)	Reference	MRP (₹)	
			*MD	*ED
630	50kA	AHA06N4P*TM(S)	255440	324540
800	50kA	AHA08N4P*TM(S)	261000	336920
1000	50kA	AHA10N4P*TM(S)	269600	341110
1250	50kA	AHA12N4P*TM(S)	326990	380860
1600	50kA	AHA16N4P*TM(S)	359210	413870
2000	50kA	AHA20N4P*TM(S)	454210	481950
2500	50kA	AHA25N4P*TM(S)	538880	582720
3200	65kA	AHA30S4P*TM(S)	660770	717570
4000	65kA	AHA40S4P*TM(S)	891100	916000
4000	85kA	AH40D4CSTM*(S)	899210	958060

NOTES: All configurable products are non stockable.



Air Circuit Breaker

AHA ACB – ORDERING INFORMATION

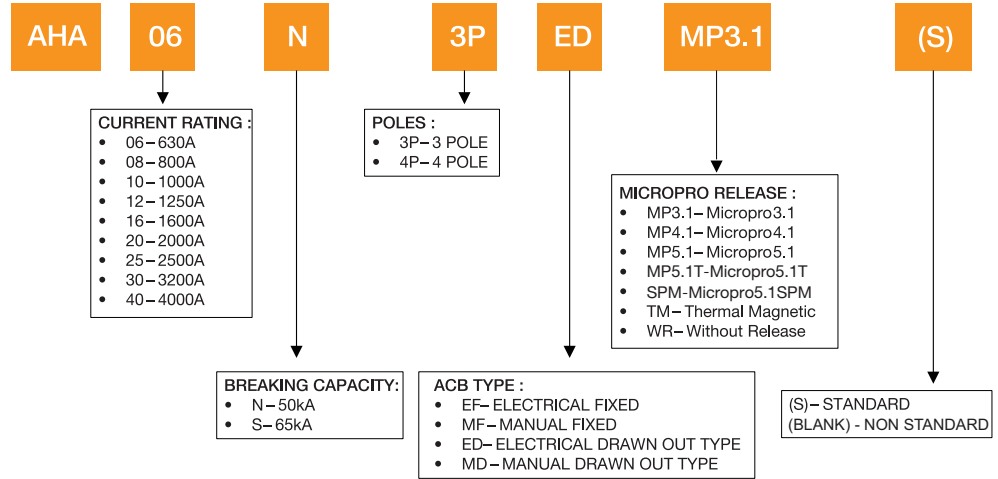

Price & Reference changes as per the release modification	Ordering Code	MRP (₹)
MicroPro 4.1 (LSING, Display, Current Measurement, Trip History, Communication) add to the price of ACB with MP3.1	ADD	19440
MicroPro5.1 (LSING, Display, Current Measurement, Trip History, ZSI, Communication) add to the price of ACB with MP3.1	ADD	29220
MicroPro5.1 SPM (LSING, Display, Current Measurement, Trip History, ZSI, Communication, Power, Motor Protection) add to the price of ACB with MP3.1	ADD	42290
MicroPro5.1T (LSING, Display, Current Measurement, Trip History, ZSI, Temperature Sensing) add to the price of ACB with MP3.1	ADD	54340

NOTES:

- 1) In TP ACB if Earth Fault facility is required, add price of Neutral CTs from table no. 4.1 on page 20.
- 2) Drawout type ACB with vertical terminal (factory fitted only) is available in ratings 8D-16D/06N-20S (AHA)
- 3) Fixed type ACB with vertical terminal adapter option is available in rating 8D-16D/06N-20S (AHA).
- 4) All configurable products are non stockable.

For ordering ACB without Release following price needs to be reduced as per the rating from the price of ACB with Thermal Magnetic Release.	Remarks	MRP (₹)
630A-1600A	Reduce	6610
2000A	Reduce	8270
2500A-3200A	Reduce	10710
4000A	Reduce	12870

NOTES:

- In TP ACB if Earth Fault facility is required, add prices of Earth Fault Relay from item no. 2 on page 18 & item No. 4.2 on page 19
- Drawout type ACB with vertical terminal (factory fitted only) is available in ratings 6D-16D/08N-20S(AHA)



Air Circuit Breaker (B-Type)

630A-2000A

- Auxiliary Switch 1NO*
- Main CTs
- Shunt Trip

*Auxiliary Switch with other combination is also available. See item No. 6.1 & 6.2 only on page 20.

Manual Fixed, 3 Pole (with Thermal Magnetic Release) [HSN Code: 8536]

Rating (Amps)	Breaking Capacity Icu=Ics=Icw (1sec)	Reference	MRP (₹)
			MF
630	50kA	AH06BCSTM*(S)	118690
800	50kA	AH08BCSTM*(S)	119290
1000	50kA	AH10BCSTM*(S)	120360
1250	50kA	AH12BCSTM*(S)	136110
1600	50kA	AH16BCSTM*(S)	163700
2000	50kA	AH20BCSTM*(S)	180080

Manual Fixed, 3 Pole (with Intelligent Release MicroPro 3.1) [HSN Code: 8536]

Rating (Amps)	Breaking Capacity Icu=Ics=Icw (1sec)	Reference	MRP (₹)
			MF
630	50kA	AH06BCSMP3.1*(S)	126040
800	50kA	AH08BCSMP3.1*(S)	131240
1000	50kA	AH10BCSMP3.1*(S)	139960
1250	50kA	AH12BCSMP3.1*(S)	179430
1600	50kA	AH16BCSMP3.1*(S)	204800
2000	50kA	AH20BCSMP3.1*(S)	223320

1. Main Accessories-AH / AHA (Please specify ACB rating & type while placing order) [HSN Code: 8538]

Sl. No.	Description	Reference	MRP (₹)
1.0	Earth Fault Relay for 6D-60C / 06N-40S	CS-EFR	8680

2. Earth Fault Relay (for ACB with thermal release) [HSN Code: 8538]

Sl. No.	EFR with NCT and Wiring Bunch for 3P Breaker			EFR with Wiring Bunch for 4P Breaker	
	Description	Reference	MRP (₹)	Reference	MRP (₹)
2.1	06D/06N	CS-EFR-06D3P	11490	CS-EFR-06D4P	8330
2.2	08D/08N	CS-EFR-08D3P	11490	CS-EFR-08D4P	8330
2.3	10D/10N	CS-EFR-10D3P	11490	CS-EFR-10D4P	8330
2.4	12D/12N	CS-EFR-12D3P	11490	CS-EFR-12D4P	8330
2.5	16D/16N	CS-EFR-16D3P	11490	CS-EFR-16D4P	8330
2.6	20N/20S	CS-EFR-20N3P	11490	CS-EFR-20N4P	8330
2.7	20D	CS-EFR-20D3P	13370	CS-EFR-20D4P	8690
2.8	25D/25N	CS-EFR-25D3P	13370	CS-EFR-25D4P	8690
2.9	30S	CS-EFR-30S3P	13370	CS-EFR-30S4P	8690
2.10	30D	CS-EFR-30D3P	13370	CS-EFR-30D4P	10000
2.11	40S	CS-EFR-40S3P	13370	CS-EFR-40S4P	10000
2.12	40D	CS-EFR-40D3P	18210	CS-EFR-40D4P	10000
2.13	50C	CS-EFR-50C3P	POR	CS-EFR-50C4P	POR
2.14	60C	CS-EFR-60C3P	POR	CS-EFR-60C4P	POR

NOTES: All configurable products are non stockable.



Main Accessories For "AH/AHA" ACB

(Please specify ACB rating & type while placing orders)

[HSN Code: 8538]

3.1 Single Phase Resin Cast CTs for "AH/AHA" ACB for MicroPro 3.1, 4.1 & 5.1 Release

1CT per pole is required. In TP ACB, one additional CT will be required if, Ground Fault Protection is selected.

Sl. No.	Type	Description	Phase CT	Neutral CT	MRP (₹)
4.1.1	-	100/0.2A	CS-WMCT-014	CS-ATBWM-010	4360
4.1.2	-	200/0.2A	CS-WMCT-02	CS-ATBWM-02	4360
4.1.3	-	250/0.2A	CS-WMCT-024	CS-ATBWM-024	4360
4.1.4	-	300/0.2A	CS-WMCT-034	CS-ATBWM-030	4360
4.1.5	-	400/0.2A	CS-WMCT-044	CS-ATBWM-040	4360
4.1.6	6D / 06N	630/0.2A	CS-WMCT-064	CS-ATBWM-060	4360
4.1.7	8D/08N	800/0.2A	CS-WMCT-084	CS-ATBWM-080	4360
4.1.8	10D/10N	1000/0.2A	CS-WMCT-104	CS-ATBWM-110	4590
4.1.9	12D / 12N	1250/0.2A	CS-WMCT-124	CS-ATBWM-120	4590
4.1.10	16D / 16N	1600/0.2A	CS-WMCT-164	CS-ATBWM-160	4590
4.1.11	20N/20S	2000/0.2A	CS-WMCT-220	CS-ATBWM-220	6140
4.1.12	20D	2000/0.2A	CS-ATBWM-220	CS-ATBWM-220	6140
4.1.13	25D / 25N	2500/0.2A	CS-ATBWM-225	CS-ATBWM-225	6140
4.1.14	30S	3200/0.2A	CS-ATBWM-2532	CS-ATBWM-332	7660
4.1.15	30D	3200/0.2A	CS-ATBWM-332	CS-ATBWM-332	7660
4.1.16	40S / 40D	4000/0.2A	CS-ATBWM-440	CS-ATBWM-440	10960
4.1.17	50C	5000/0.2A	CS-ATBWM-550	CS-ATBWM-554	13040
4.1.18	60C	6300/0.2A	CS-ATBWM-660	CS-ATBWM-664	13040

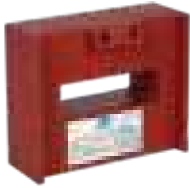

3.2 Single Phase Resin Cast CTs for "AH/AHA" ACB for Thermal release

1 CT per pole is required. In TP ACB, one additional CT will be required if, Ground Fault Protection is selected.

Sl. No.	Type	Description	Phase CT	Neutral CT	MRP (₹)
4.2.1		100/5A	CS-ATB-014	CS-ATB-010	4050
4.2.2		200/5A	CS-ATB-020	CS-ATB-020N	4050
4.2.2	-	250/5A	CS-ATB-024	CS-ATB-020	4050
4.2.4		300/5A	CS-ATB-034	CS-ATB-030	4050
4.2.5	-	400/5A	CS-ATB-044	CS-ATB-040	4050
4.2.6	6D / 06N	630/5A	CS-ATB-064	CS-ATB-060	4050
4.2.7	8D/08N	800/5A	CS-ATB-084	CS-ATB-080	4050
4.2.8	10D/10N	1000/5A	CS-ATB-104	CS-ATB-110	4160
4.2.9	12D / 12N	1250/5A	CS-ATB-134	CS-ATB-120	4270
4.2.10	16D / 16N	1600/5A	CS-ATB-164	CS-ATB-160	4820
4.2.11	20N/20S	2000/5A	CS-ATB-220	CS-ATB-220	5460
4.2.12	20D	2000/5A	CS-ATB-220	CS-ATB-220	5460
4.2.13	25D / 25N	2500/5A	CS-ATB-225	CS-ATB-225	6140
4.2.14	30S	3200/5A	CS-ATB-2532	CS-ATB-332	7110
4.2.15	30D	3200/5A	CS-ATB-332	CS-ATB-332	7110
4.2.16	40S / 40D	4000/5A	CS-ATB-440	CS-ATB-440	10180
4.2.17	50C	5000/5A	CS-ATB-554	CS-ATB-550	12820
4.2.18	60C	5000/5A	CS-ATB-664	CS-ATB-660	12820

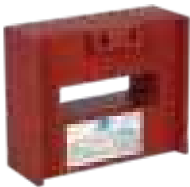

NOTES: All configurable products are non stockable.



Air Circuit Breaker

Main Accessories For "AH/AHA" ACB

(Please specify ACB rating & type while placing orders)

4. Auxiliary Switch

[HSN Code: 8538]

Sl. No.	Description	Reference	MRP (₹)	
4.1	5 way (3NO+2NC)	6D-16D/06N-20S	CS-AXH-3A2B-116	2140
		20D-40D/25N-40S	CS-AXH-3A2B-220	2140
4.2	10 way (5NO+5NC)	6D-16D/08N-20S	CS-AXH-5A5B-116	3230
		20D-40D/25N-40S / 50C-60C	CS-AXH-5A5B-220	3230
4.3	14 way (7NO+7NC)	6D-16D/06N-20S	CS-AXH-7A7B-116	5270
		20D-40D/25N-40S / 50C-60C	CS-AXH-7A7B-220	5270

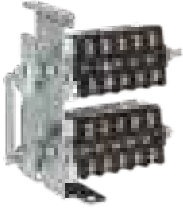

5. UVT Device

[HSN Code: 8538]

Sl. No.	Description	Reference	MRP (₹)
5.1	Compact UVT Coil 6D-16D/06N-20S	CS-AUH-V-A-**	7390
5.2	20D-40D/25N-40S / 50C-60C	CS-AUH-V-B-**	7390

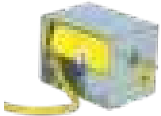

6. Shunt Trip and Closing Coil

[HSN Code: 8538]

Sl. No.	Description	Reference	MRP (₹)
6.1	Shunt Trip 6D-16D/06N-20S	CS-AVH-S-116-**	4110
	20D-40D/25N-40S/50C-60C	CS-AVH-S-220-**	4110
6.2	Closing Coil 6D-16D/06N-20S	CS-AVH-C-116-**	4110
	20D-40D/25N-40S/ 50C-60C	CS-AVH-C-220-**	4110



**Please specify voltage while ordering

**Options for Coils Voltage

Description	AC Control Voltage			DC Control Voltage			
	100~130V	220~250V	380~440V	24V	48V	100~130V	220~250V
UVT	FA	MA	NA	-	-	FD	MD
SHUNT	FA	MA	NA	BD	ED	FD	MD
Closing Coil	FA	MA	NA	BD	ED	FD	MD

[HSN Code: 8538]

Sl. No.	Description	Suitable for ACB frame size / rating			
		6D-16D / 06N-20S Reference	MRP (₹)	20D-40D/25S-40S / 50C-60C Reference	MRP (₹)
7	OCR (Fault) Alarm Switch (for fault indication in ACB with MP & TM release)	ALA-1	1240	ALA-2	1240
8	Trip Indication Switch (For both manual and Fault indication in ACB)	CS-TIS-1	1240	CS-TIS-2	1240
9	Spring Charged Indication Switch	SCIS-M	1630	SCIS-M2	1630
10	Position Indication Switch (Right side)	ALB-4P-1	4060	ALB-IP-2	4060
11	Position Indication Switch (Left side)	ALB-FR-1-L	4060	ALB-FR-2-L	4060
12	Mechanical operation counter	ASC-1	3760	ASC-2	3760
13	Key Lock (One lock + One key)	AKI-116D	2850	AKI-2D	2850
14	Castle Key Lock-3 Pole	CKI-116 (3P)	8750	CKI-220 (3P)	8750
	Castle Key Lock-4 Pole	CKI-116 (4P)	8750	CKI-220 (4P)	8750
15	Key Interlock (Consisting of 3-Key Locks with 2 Keys (same No.) fitted on 3 ACBs)	AKI-1-1	7770	AKI-1-2	7770
16	Key Interlock (Consisting of 2-Key Locks with 1 Key (same No.) fitted on 2 ACBs)	AKI-2-1	5950	AKI-2-2	5950
17	Short Circuit Contact for Shunting Auxiliary Isolating Contacts when ACB withdrawn	SCC	700	SCC	700
18	Rectifier Unit input 240V AC / output 24V DC, used for Fault LED Retention	CS-ARO-1BMA	4060	CS-ARO-1BMA	4060
19	Mal Insertion Preventor	MIP-NPCIL	POR	MPI-2-NPCL	POR



NOTES: All configurable products are non stockable.



AH / AHA ACB Order Form

Please fill separate sheet for each type of ACB Tick the box in front of each appropriate item and fill in the blanks.

AH/AHA ACB ORDER FORM																								
Customer Name		Order No & Date		Delivery Date		End User/Panel Builder Name & Phone no.			Qty. (NOS.)															
PRODUCT REFERENCE		AH <input type="checkbox"/>		AHA <input type="checkbox"/>																				
RATING OF ACB REQUIRED	630A <input type="checkbox"/>		800A <input type="checkbox"/>		1000A <input type="checkbox"/>		1250A <input type="checkbox"/>		1600A <input type="checkbox"/>		2000A <input type="checkbox"/>													
	2500A <input type="checkbox"/>		3200A <input type="checkbox"/>		4000A <input type="checkbox"/>		5000A <input type="checkbox"/>		6300A <input type="checkbox"/>															
NO. OF POLES	3 POLE <input type="checkbox"/>		4 POLE <input type="checkbox"/>		BREAKING CAPACITY : AH : D C (Only for 50C & 60C)																			
					AHA : N S																			
STANDARD CONFIGURATION	MF		EF		MDO		EDO																	
	Release		Release		Release		Release																	
	Power Supply Module (ac/dc)		Power Supply Module (ac/dc)		Power Supply Module (ac/dc)		Power Supply Module (ac/dc)																	
	Aux Switch 4NO + 4NC		Aux Switch 3NO + 4NC		Aux Switch 4NO + 4NC		Aux Switch 4NO + 4NC																	
	Main CTs		Main CTs		Main CTs		Main CT s																	
			Charging Motor		Safety shutter		Charging Motor																	
			Shunt Trip		36 Way Aux Isolating Contacts		Shunt Trip																	
			Closing Coil				Closing Coil																	
			Anti Pumping Relay				Anti Pumping Relay																	
							Safety shutter																	
							36 Way Aux Isolating Contacts																	
	MF		EF		MDO		EDO																	
	Thermal Magnetic Release		Thermal Magnetic Release		Thermal Magnetic Release		Thermal Magnetic Release																	
	Aux Switch 4NO + 4NC		Aux Switch 3NO + 4NC		Aux Switch 3NO + 3NC		Aux Switch 5NO + 6NC																	
	Main CTs		Charging Motor		Main CTs		Main CT s																	
	Shunt Trip		Main CTs		Shunt Trip		Safety shutter																	
			Shunt Trip		Safety shutter		Charging Motor																	
			Closing Coil		24 Way Aux Isolating Contacts		Closing Coil																	
			Anti Pumping Relay				Shunt Trip																	
							Anti Pumping Relay																	
						36 Way Aux Isolating Contacts																		
VOLTAGE RATING	Motor --->		<table border="1" style="display: inline-table; border-collapse: collapse;"> <tr><td>110V</td><td>AC</td><td>DC</td></tr> <tr><td>220V</td><td>AC</td><td>DC</td></tr> </table>		110V	AC	DC	220V	AC	DC	Closing Coil -->		<table border="1" style="display: inline-table; border-collapse: collapse;"> <tr><td>100-130V AC</td><td>220-250V AC</td><td>380-440V AC</td></tr> <tr><td>24V DC</td><td>48V DC</td><td>110V DC</td><td>220V DC</td></tr> </table>		100-130V AC	220-250V AC	380-440V AC	24V DC	48V DC	110V DC	220V DC			
	110V	AC	DC																					
220V	AC	DC																						
100-130V AC	220-250V AC	380-440V AC																						
24V DC	48V DC	110V DC	220V DC																					
UVT ----> (W/O time delay)		<table border="1" style="display: inline-table; border-collapse: collapse;"> <tr><td>100-130V AC</td><td>220-250V AC</td><td>380-440V AC</td></tr> <tr><td>110V DC</td><td>220V DC</td><td></td></tr> </table>		100-130V AC	220-250V AC	380-440V AC	110V DC	220V DC		Shunt trip coil -->		<table border="1" style="display: inline-table; border-collapse: collapse;"> <tr><td>100-130V AC</td><td>220-250V AC</td><td>380-440V AC</td></tr> <tr><td>24V DC</td><td>48V DC</td><td>110V DC</td><td>220V DC</td></tr> </table>		100-130V AC	220-250V AC	380-440V AC	24V DC	48V DC	110V DC	220V DC				
100-130V AC	220-250V AC	380-440V AC																						
110V DC	220V DC																							
100-130V AC	220-250V AC	380-440V AC																						
24V DC	48V DC	110V DC	220V DC																					
ACCESSORIES	Without Release <input type="checkbox"/>		CT Rating _____ A		Thermal Magnetic : Earth Fault : Req'd. <input type="checkbox"/> Not Req'd. <input type="checkbox"/> CT Rating <input type="checkbox"/> NCT Rating <input type="checkbox"/> Setting of non-adj. Mag. Inst. Trip _____																			
	Thermal Magnetic Release <input type="checkbox"/>		Overload _____ A																					
	MicroPro 3.1 <input type="checkbox"/>		Ground Fault _____ A																					
	MicroPro 4.1 <input type="checkbox"/>		Short Circuit _____ A																					
	MicroPro 5.1 <input type="checkbox"/>		Instantaneous _____ A																					
	Communication Module* (Modbus Protocol) <input type="checkbox"/>		Neutral _____ A																					
ACCESSORIES	Trip Ind. Switch <input type="checkbox"/>		Spring charge Ind. Switch <input type="checkbox"/>		Castle Key Interlock** <input type="checkbox"/>																			
	Position Ind. Switch <input type="checkbox"/>		Mech. Operation Counter <input type="checkbox"/>		Key Interlock : 2 ACB <input type="checkbox"/>		3 ACB <input type="checkbox"/>																	
	Key Lock** <input type="checkbox"/>		Door Interlock <input type="checkbox"/>		Neutral CT <input type="checkbox"/>																			
	OCR Alarm Switch <input type="checkbox"/>		Mechanical Interlock : Hor. <input type="checkbox"/> Ver. <input type="checkbox"/>																					
Special Requirements, If any																								
NOTES:	(1) Neutral CT is required alongwith MicroPro Release having Ground-Fault Protection for 3P ACB, used for 3 phase 3 wire system. This has to be mounted on Earth / NeutralBusbar of Panel.																							
	(2) 220V AC Shunt/Closing.Coil/Motor is provided as standard.																							
	(3) Castle lock is not available for C-type Breaker.																							
(4) For WR ACB, Aux contact shall be 4NO+4NC for MF and 3NO+4NC for EF &3NO + 3 NC for MDO and 5NO+6NC for EDO.																								
** (Breaker will be fitted either with Key lock or with Castle key interlock)																								
* (220V AC input is required)																								

NOTE: For thermal magnetic EDO ACB with EFR, Aux Contact shall be 4NO+6NC

MCCB with Enhanced Monitoring and Control



Communicable

Real Time Data

Remote Control
& Monitoring

Data Driven
Decision Making



RoHS
Compliant

- Complying to IEC 60947-2
- Unique 'Reserve Trip Assembly'
- Suitable for voltage up to 690V / Ui 1000V AC
- Suitable for Motor loads, Capacitor switching
- 100% Ics value ensuring high performance
- Total Selectivity
- Multiple trip units offering variety of choice for the user
- Available with a 'Single Pole' variant MCCB
- Inbuilt Current Measurement & last trip history
- Communication option available



WiNbreak1 MCCB



- Conforms to IS/IEC 60947-2
- Ics=100% Icu, 75% Icu
- Range: 16A-630A, 3 & 4 Pole
- Breaking capacity: 10kA to 55kA Max.
- Positive Isolation
- Trip free mechanism
- Neutral with 100% rated current
- Bounce free contact structure
- Wide range of Internal & External Accessories
- SS Enclosure available
- Standard packing includes insulating phase barrier and hardware

FMU (Thermal Magnetic) Release • Adjustable Overload 80-100% • Fixed short circuit [HSN Code: 8536]

Size	Rated Current (Amps)	Breaking capacity Icu at 415V AC	3 Pole Reference	MRP (₹)	4 Pole Reference	MRP (₹)
Frame 1	16, 20, 25, 32, 40, 50	25kA	CSE1M125FMU3P-*	8840	CSE1M125FMU4P-*	11360
	16, 20, 25, 32, 40, 50	36kA	CSE1NN125FMU3P-*	11340	CSE1NN125FMU4P-*	13820

ATM (Thermal Magnetic) Release • Adjustable Overload 80-100% • Adjustable Short Circuit 5-10 In

Size	Rated Current (Amps)	Breaking capacity Icu at 415V AC	3 Pole Reference	MRP (₹)	4 Pole Reference	MRP (₹)	
Frame 1	63, 80, 100	25kA	CSE1M125ATM3P-*	9440	CSE1M125ATM4P-*	12470	
	125		CSE1M125ATM3P-*	12930	CSE1M125ATM4P-*	14540	
	160		CSE2M250ATM3P-*	16880	CSE2M250ATM4P-*	20230	
Frame 2	200		CSE2M250ATM3P-*	21310	CSE2M250ATM4P-*	24300	
	250		CSE2M250ATM3P-*	25230	CSE2M250ATM4P-*	28690	
Frame 3	320		CSE3M400ATM3P-*	32160	CSE3M400ATM4P-*	37570	
	350		CSE3M400ATM3P-*	32160	CSE3M400ATM4P-*	37570	
	400		CSE3M400ATM3P-*	32640	CSE3M400ATM4P-*	39660	
Frame 1	63, 80, 100		36kA	CSE1NN125ATM3P-*	11340	CSE1NN125ATM4P-*	14230
	125			CSE1NN125ATM3P-*	13250	CSE1NN125ATM4P-*	15460
Frame 2	160			CSE2NN250ATM3P-*	19540	CSE2NN250ATM4P-*	24830
	200			CSE2NN250ATM3P-*	23730	CSE2NN250ATM4P-*	26730
Frame 3	320	CSE3NN400ATM3P-*		32380	CSE3NN400ATM4P-*	37990	
	350	CSE3NN400ATM3P-*		32380	CSE3NN400ATM4P-*	37990	
	400	CSE3NN400ATM3P-*		32810	CSE3NN400ATM4P-*	40090	
Frame 4	500	CSE4NN630ATM3P-*		36790	CSE4NN630ATM4P-*	46140	
	630	CSE4NN630ATM3P-*		36790	CSE4NN630ATM4P-*	46140	
Frame 1	63, 80, 100	50kA		CSE1S125ATM3P-*	15100	CSE1S125ATM4P-*	18320
	125			CSE1S125ATM3P-*	17700	CSE1S125ATM4P-*	22160
Frame 2	160			CSE2S250ATM3P-*	23390	CSE2S250ATM4P-*	29980
	200			CSE2S250ATM3P-*	26480	CSE2S250ATM4P-*	32210
	250			#CSE2SX250ATM3P-*	27070	#CSE2SX250ATM4P-*	33500
Frame 3	250			CSE2S250ATM3P-*	28340	CSE2S250ATM4P-*	35180
	320			CSE3S400ATM3P-*	34170	CSE3S400ATM4P-*	39490
	350			CSE3S400ATM3P-*	34170	CSE3S400ATM4P-*	39490
Frame 4	400			CSE3S400ATM3P-*	35550	CSE3S400ATM4P-*	40730
	500		CSE4S630ATM3P-*	46570	CSE4S630ATM4P-*	57230	
	630		CSE4S630ATM3P-*	46570	CSE4S630ATM4P-*	57230	

- NOTES :**
1. #Icu 50kA(Ics=75% Icu)
 2. While Ordering, Replace*** by Current Rating, followed by 'A' eg., 350A
 3. For spreader terminals reference code & MRP, please refer page no. 29
 4. For 55kA MCCB & 2 Pole version MCCB please contact to nearest Branch Office.

WiNbreak1 MCCB

Microprocessor Release 'MicroPro WB'

- Conforms to IS/IEC 60947-2
- Ics=100%Icu
- Range: 40A-630A, 3P & 4P
- Breaking capacity: 36kA & 50kA
- Communication*
- Trip History
- LCD: Indication of measurement and information
- Suitable for isolation
- Adjustable over load from 0.4-1.0In
- Adjustable short circuit from 2-12Ir
- Inbuilt ground fault protection available 20% to 100% of In
- Adjustable neutral overload protection available: 50% to 100% of Ir
- Adjustable current imbalance protection available: (30%-70%) of Ir
- Provision of thermal memory: ON/OFF
- View last trip information



ETM (with in-built Earth fault Protection) • Adjustable Overload 40 - 100%

[HSN Code: 8536]

• Adjustable shortcircuit 2-12 Ir

Size	Release Range (A)	Breaking Capacity Icu at 415V AC	3 Pole Reference	MRP (₹)	4 Pole Reference	MRP (₹)
Frame 1	16-40	36kA	CSE1NN125ETM3P-40A	23030	CSE1NN125ETM4P-40A	27070
	25-63		CSE1NN125ETM3P-63A	23030	CSE1NN125ETM4P-63A	27070
	40-100		CSE1NN125ETM3P-100A	24400	CSE1NN125ETM4P-100A	28420
	50-125		CSE1NN125ETM3P-125A	25200	CSE1NN125ETM4P-125A	30990
Frame 2	63-160		CSE2NN250ETM3P-160A	28920	CSE2NN250ETM4P-160A	34040
	80-200		CSE2NN250ETM3P-200A	34350	CSE2NN250ETM4P-200A	42290
Frame 3	160-400		CSE3NN400ETM3P-400A	51080	CSE3NN400ETM4P-400A	63720
Frame 4	250-630		CSE4NN630ETM3P-630A	54910	CSE4NN630ETM4P-630A	69540

ETM (with in-built Earth fault Protection) • Adjustable Overload 40-100%

[HSN Code: 8536]

• Adjustable short circuit 2-12 Ir • Ics=100%Icu

Size	Release Range (A)	Breaking Capacity Icu at 415V AC	3 Pole Reference	MRP (₹)	4 Pole Reference	MRP (₹)
Frame 1	16-40	50kA	CSE1S125ETM3P-40A	25490	CSE1S125ETM4P-40A	28450
	25-63		CSE1S125ETM3P-63A	25490	CSE1S125ETM4P-63A	28450
	40-100		CSE1S125ETM3P-100A	25490	CSE1S125ETM4P-100A	28450
	50-125		CSE1S125ETM3P-125A	26090	CSE1S125ETM4P-125A	34270
Frame 2	63-160		CSE2S250ETM3P-160A	32470	CSE2S250ETM4P-160A	40660
	80-200		CSE2S250ETM3P-200A	34830	CSE2S250ETM4P-200A	42950
	100-250		CSE2S250ETM3P-250A	34970	CSE2S250ETM4P-250A	51550
	100-250		#CSE2SX250ETM3P-250A	35360	#CSE2SX250ETM4P-250A	45160
Frame 3	160-400	CSE3S400ETM3P-400A	53590	CSE3S400ETM4P-400A	68450	
Frame 4	250-630	CSE4S630ETM3P-630A	64180	CSE4S630ETM4P-630A	84310	

NOTE: 1. #Icu 50kA(Ics=75% Icu)

2. While ordering, Replace "*" with Current rating

3. For spreader terminals reference code & MRP, please refer page no. 29

4. For 3 Pole ETM (Microprocessor) MCCB one Neutral CT will be required, if ground fault protection is required. For reference & price please refer page 30.

5. *For Communication Module details please contact nearest Branch Office.



WiNbreak1 MCCB - Frame 'S'



- Conforms to IS/IEC 60947-2
- Ics=100%Icu (for 10kA & 18kA), 75% & 50% for 10kA, 75% for 25kA
- Range: 16A-125A
- Breaking Capacity: 10kA, 18kA & 25kA
- Compact Size
- Quick free mechanism
- Precise settings
- Termination possibility for unprepared cables
- Flexibility for installation as Horizontal / Vertical
- Standard packing includes insulating phase barrier and hardware

FMU (Thermal Magnetic) Release • Adjustable Overload 80-100% [HSN Code: 8536]
• Fixed short circuit 10In*

Size	Rating Range (A)	Breaking Capacity Icu at 415V AC	3 Pole Reference	MRP (₹)	4 Pole Reference	MRP (₹)
Frame 'S'	16, 20, 25, 32, 40, 50	10kA	CSESK125FMU3P-*A	3730	CSESK125FMU4P-*A	4230
	63, 80, 100A		CSESK125FMU3P-*A	4500	CSESK125FMU4P-*A	6010
	125A		CSESK125FMU3P-*A	4910	CSESK125FMU4P-*A	6270
	16, 20, 25, 32, 40, 50	18kA	CSESL125FMU3P-*A	5820	CSESL125FMU4P-*A	7610
	63, 80, 100A		CSESL125FMU3P-*A	5970	CSESL125FMU4P-*A	7770
	125A		CSESL125FMU3P-*A	6400	CSESL125FMU4P-*A	8510
	16, 20, 25, 32, 40, 50	25kA*	CSESMX125FMU3P-*A	6310	CSESMX125FMU4P-*A	7760
	63, 80, 100A		CSESMX125FMU3P-*A	6570	CSESMX125FMU4P-*A	8140
	125A		CSESMX125FMU3P-*A	6890	CSESMX125FMU4P-*A	8540

- NOTES :**
1. While Ordering, Replace "*" by Current Rating.
 2. * Ics=75%Icu
 3. For accessories please refer page No. 29
 4. Frame 'S' MCCB with box type terminal is also available on request.
 5. *From 63-125A



Single Pole MCCB

- Conforms to IS/IEC 60947-2
- Ics=100%Icu
- Range: 16A-125A
- Breaking capacity: 10kA
- Standard packing does not includes Spreader terminals

FTM (Thermal Magnetic) Release • Fixed Overload • Fixed short circuit [HSN Code: 8536]

Size	Rating (A)	Breaking Capacity Icu at 240V AC	Reference	MRP (₹)
Frame 1	16, 20, 25, 32, 40	10kA	CSESK125FTM1P-16A	1580
			CSESK125FTM1P-20A	1580
			CSESK125FTM1P-25A	1580
			CSESK125FTM1P-32A	1580
			CSESK125FTM1P-40A	1580
			CSESK125FTM1P-50A	1750
	50, 63, 80, 100, 125		CSESK125FTM1P-63A	1750
			CSESK125FTM1P-80A	1750
			CSESK125FTM1P-100A	1750
			CSESK125FTM1P-125A	1750



WiNbreak1 MCCB

MCCB for Motor Protection

- Conforms to IS/IEC 60947-2
- Ics=100% Icu
- Range 20A~630A
- Breaking Capacity -50kA
- Upto 50A-Fixed Magnetic setting - Upto 17In
- Adjustable Magnetic setting 6~12In for rating above 50A
- Positive Isolation
- Trip Free mechanism
- Standard packing includes phase barriers and hardware

FMTU (Fixed Magnetic) Release • MTU (Adjustable Magnetic) Release [HSN Code: 8536]
• Adjustable short circuit upto 6~12In

Size	Breaking Capacity Icu at 415V AC	Rating (A)	3 Pole - Reference	MRP (₹)
Frame-1	50kA	20	CSE1S125FMTU3P-20A	10560
		32	CSE1S125FMTU3P-32A	10560
		50	CSE1S125FMTU3P-50A	10560
		63	CSE1S125MTU3P-63A	10740
		100	CSE1S125MTU3P-100A	10740
		125	CSE1S125MTU3P-125A	12050
Frame-2	50kA	160	CSE2S250MTU3P-160A	18660
		200	CSE2S250MTU3P-200A	24190
		220	CSE2S250MTU3P-220A	30080
		250	CSE2S250MTU3P-250A	30080
Frame-3	50kA	320	CSE3S400MTU3P-320A	35780
		350	CSE3S400MTU3P-350A	35780
		400	CSE3S400MTU3P-400A	35780
Frame-4	50kA	500	CSE4S630MTU3P-500A	36550
		630	CSE4S630MTU3P-630A	36550

ACCESSORIES - Suitable for use on WB1 MCCBs [HSN Code: 8538]

MCCB	Shunt Trip (SHT)	MRP (₹)	Under Voltage Trip (UVT)	MRP (₹)	Auxiliary Switch (AX)	MRP (₹)	Alarm Switch (AL)	MRP (₹)	Combination Switch (AX+AL)	MRP (₹)
CSES	STW1-S (...V)	1670	-	-	AXWS-L	1270	ALWS-L	1360	XLWS-L	2420
CSE1	STW1-(...V)	2840	UVTW1-(...V)	4920	AXW1-*	1480	ALW1-*	1480	XLW1-*	3510
CSE2							ALW1-2*	1480	XLW1-2*	3510
CSE3/CSE4	STW1-3(...V)	4210	UVTW1-3(...V)	5750	AXW1-3*	1880	ALW1-3*	1880	XLW1-3*	4210

NOTE:

1. Please replace "*" with L as MCCB Left hand side position & R as MCCB right hand position
2. Maximum Possibilities for Internal Accessories
 - a) 3 Pole, MCCB with Thermal Release, Any two accessories can be fitted at one time
 - b) 4 Pole, MCCB with Thermal Release, Any Three accessories can be fitted at one time
 - c) 3 Pole, MCCB with Microprocessor Release, Right hand seat is not available. Hence, one accessory can be fitted at one time
 - d) 4 Pole, MCCB with Microprocessor Release, Any two accessories can be fitted at one time; Right hand seat is not available
 - e) Alarm & combination switch can be fitted in left hand seat only on CSE3-4P Microprocessor Release MCCB
 - f) UVT can be fitted only in left hand seat
 - g) 3 & 4 Pole, CSES MCCB can have Shunttrip fitment only in Right Side pocket
3. For UVT of CSES Fame, please contact to nearest Branch Office
4. Please Replace (...) with voltage rating
5. For 24V & 48V Shunt, please contact to nearest Branch Office

Voltage Selection UVT & Shunt

Size	AC	DC	AC / DC Common
UVT			
CSE1/CSE2	220V, 415V	24V, 48V, 110V, 220V	-
CSE3/CSE4	220V, 415V		220V
Shunt			
CSES	110V, 220V, 415V	110V, 220V	-
CSE1/CSE2	220V, 415V		-
CSE3/CSE4	220V, 415V		24V, 48V, 110V



Winbreak1 MCCB

Extended Rotary Handle [HSN Code: 8538]

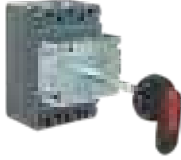

Suitable for use on WB1 MCCBs	Reference	MRP (₹)
CSES	EHW1-0T-125	2650
CSE1	EHW1-125	2950
CSE2	EHW1-250	3470
CSE3 / CSE4	EHW1-400-630	4150

Panel Door Mounted Key Lock for Extended Rotary Handle [HSN Code: 8538]



Suitable for use on WB1 MCCBs	Reference Code	MRP (₹)
CSE1	EXTKLWB1-125AF-T1	4800
CSE2	EXTKLWB1-250AF-T1	4800
CSE3 / CSE4	EXTKLWB1-400AF-T1	5640

Mechanical Interlock [HSN Code: 8538]

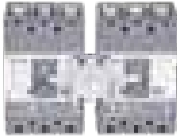

Suitable for use on WB1 MCCBs	Applied between two MCCBs			
	Reference 3 Pole	MRP (₹)	Reference 4 Pole	MRP (₹)
CSE1	MIW1-125-3P	3430	MIW1-125-4P	4250
CSE2	MIW1-250-3P	3730	MIW1-250-4P	4420

Note: For CSE3/CSE4 mechanical interlock, please contact with nearest Branch Office.

Locking Devices* [HSN Code: 8538]

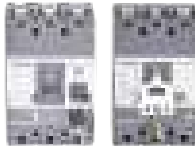

Suitable for use on MCCBs	Key Lock*		Padlocking	
	Reference	MRP (₹)	Reference	MRP (₹)
CSE1	KLW1-125	1920	PLW1-125	2010
CSE2	KLW1-250	2080	PLW1-250	2230
CSE3 / CSE4	-	-	PLW1-400	3890

* Factory fitted only

Spreader Terminals for WB1 MCCB [HSN Code: 8538]



Suitable for use on MCCBs		Current Rating (A)	Reference	MRP (₹)	MOQ
CSES	3 Pole	16 , 20, 25, 32, 40, 50, 63, 80, 90, 100, 125	CSET0033	220	Set of 3
	4 Pole		CSET0044	330	Set of 4
CSE1	3 Pole	16, 20, 32, 40, 50, 63	CSET1033	220	Set of 3
CSE1	3 Pole	80, 100, 125	CSET1033C	320	Set of 3
CSE1	4 Pole	16, 20, 32, 40, 50, 63	CSET1044	360	Set of 4
CSE1	4 Pole	80, 100, 125	CSET1044C	450	Set of 4
CSE2	3 Pole	160, 200	CSET2033	540	Set of 3
CSE2	3 Pole	250	CSET2503-ST	870	Set of 3
CSE2	4 Pole	160, 200	CSET2044	800	Set of 4
CSE2	4 Pole	250	CSET2504-ST	1130	Set of 4
CSE3	3 Pole	320, 350, 400	CSET3033	1960	Set of 3
CSE3	4 Pole	320, 350, 400	CSET3044	2710	Set of 4
CSE4	3 Pole	500, 630	CSET4033-WB1	4340	Set of 3
CSE4	4 Pole	500, 630	CSET4044-WB1	5900	Set of 4

SS Enclosure for WB1 MCCB [HSN Code: 8538]



Size	Suitable for WB1 MCCBs	Reference	MRP (₹)
FrameS	CSES	CSE-ENCL-125S-3P	2570
	CSES	CSE-ENCL-125S-4P	2570
Frame1	CSE1	CSE-ENCL-125-3P	2740
	CSE1	CSE-ENCL-125-4P	2740
Frame2	CSE2	CSE-ENCL-250-3P	4730
	CSE2	CSE-ENCL-250-4P	4730

NOTES:

- Reference Code is for Enclosure only (without MCCB)
- For Placing an order for MCCB along with Enclosure, please apply prefix E-before MCCB Reference Code. For Price, please contact nearest Branch Office.

Winbreak1 MCCB

Motor Operator for WB1		[HSN Code: 8538]
Description	Reference	MRP (₹)
CSE1MOP24VDC	Motor Operator For Winbreak1 (CSE1 24V DC)	28750
CSE1MOP110VAC/DC	Motor Operator For Winbreak1 (CSE1 110V AC/DC)	28750
CSE1MOP220VAC/DC	Motor Operator For Winbreak1 (CSE1 220V AC/DC)	28750
CSE1MOP400VAC	Motor Operator For Winbreak1 (CSE1 400V AC)	28750
CSE2MOP24VDC	Motor Operator For Winbreak1 (CSE2 24V DC)	32190
CSE2MOP110VAC/DC	Motor Operator For Winbreak1 (CSE2 110V AC/DC)	32190
CSE2MOP220VAC/DC	Motor Operator For Winbreak1 (CSE2 220V AC/DC)	32190
CSE2MOP400VAC	Motor Operator For Winbreak1 (CSE2 400V AC)	32190
CSE3/4MOP24VDC	Motor Operator For Winbreak1 (CSE3/4 24V DC)	47720
CSE3/4MOP110VAC/DC	Motor Operator For Winbreak1 (CSE3/4 110V AC/DC)	47720
CSE3/4MOP220VAC/DC	Motor Operator For Winbreak1 (CSE3/4 220V AC/DC)	47720
CSE3/4MOP400VAC	Motor Operator For Winbreak1 (CSE3/4 400V AC)	47720

Earth Fault Relay (Built in CBCT) Suitable for 3 Phase 3 wire distribution network		[HSN Code: 8538]
Rating (Amps)	Earth Fault Relay Setting Range	MRP (₹)
32A	3.2-32A	8100
40A	4-40A	8100
63A	6.3-63A	8100
80A	8-80A	8100
100A	10-100A	8100
125A	12.5-125A	8620
200A	20-200A	8620
250A	25-250A	9640
400A	40-400A	9640
630A	63-630A	11160
800A	80-800A	11160
1000A	100-1000A	17220
1250A	125-1250A	17220

Earth Fault Relay (with NCT) Suitable for 3 Phase 4 wire distribution network		
40A	4-40A	7500
100A	10-100A	7500
125A	12.5-125A	7970
200A	20-200A	7970
250A	25-250A	8890
400A	40-400A	8890
630A	63-630A	10240
800A	80-800A	10240
1000A	100-1000A	16880
1250A	125-1250A	16880

NCT Winbreak1 ETM (Microprocessor) 3 Pole MCCB if ground fault facility is required		
40	40/0.1A	2470
63	63/0.1A	2470
80	80/0.1A	2470
100	100/0.1A	2470
125	125/0.1A	2470
160	160/0.1A	3460
200	200/0.1A	3460
250	250/0.1A	3460
400	400/0.1A	4730



WiNbreak2

An Absolute solution for power distribution

C&S Electric offers innovative, intelligent,
integrated and intuitive solution



- Conforms to IS/IEC 60947-2
- $I_{cs} = 100\% I_{cu}$
- $I_{cw} = 25kA / 1s$
- Range: 800A to 1600A, 3P & 4P
- Breaking Capacity: 50kA, 70kA & 150kA
- U_i : 1000V
- U_{imp} : 8kV

N Type (Normal)





WiNbreak2 MCCB (1600AF)

Features:

- LSI Protection
- Thermal Memory
- Current, Voltage, Power, Energy, Frequency measurement
- Trip History
- Digital Display
- Fault recording
- Event Recording
- Communication
- Harmonics
- True RMS Sensing
- ZSI
- IDMTL Setting
- Self Power
- LED for Tripping Information
- RTC Timer
- Pre Trip Alarm

MCCB with Intelligent Release - N Type [HSN Code: 8536]

Size	Release Range (A)	Breaking Capacity @ 415VAC	3 Pole Reference	MRP (₹)	4 Pole Reference	MRP (₹)
Frame 5	400-800	50kA	CS1000NNG5800A3P	POR	CS1000NNG5800A4P	POR
	500-1000		CS1000NNG51000A3P		CS1000NNG51000A4P	
	625-1250		CS1250NNG51250A3P		CS1250NNG51250A4P	
	800-1600		CS1600NNG51600A3P		CS1600NNG51600A4P	
	400-800	70kA	CS1000HNG5800A3P	POR	CS1000HNG5800A4P	POR
	500-1000		CS1000HNG51000A3P		CS1000HNG51000A4P	
	625-1250		CS1250HNG51250A3P		CS1250HNG51250A4P	
	800-1600		CS1600HNG51600A3P		CS1600HNG51600A4P	

Internal Accessories [HSN Code: 8538]

WB2 MCCBs	Shunt Trip (SHT)	MRP (₹)	Under Voltage Trip (UVT)	MRP (₹)	Auxiliary Switch (AX)	MRP (₹)	Alarm Switch (AL)	MRP (₹)	Fault Alarm Switch (FAL)*	MRP (₹)
CS1000-1600	SHT5-T(...V)	POR	UVT5-T(...V)	POR	AX5-T	POR	AL5-T	POR	FAL5-T	POR

Voltage Selection UVT & Shunt

Size	AC	DC	AC / DC Common
UVT			
Frame 5	48V, 380-480V	24-30V, 48-60V	100-130V, 200-250V
Shunt			
Frame 5	48V, 380-480V	24-30V, 48-60V	100-130V, 200-250V

WB2 MCCBs	Direct Rotary Handle	MRP (₹)	Direct Rotary Handle with Keylock	MRP (₹)	Extended Rotary Handle	MRP (₹)
CS1000-1600	DH5-S	POR	DHK5-S	POR	EH5-S	POR

Mechanical Interlock [HSN Code: 8538]

WB2 MCCBs	Applied between two MCCBs			
	3 Pole		4 Pole	
	Reference	MRP (₹)	Reference	MRP (₹)
CS1000-1600	MIT53	POR	MIT54	POR

Padlocking Device [HSN Code: 8538]

WB2 MCCBs	Fixed Lock		Removable Lock	
	Reference	MRP (₹)	Reference	MRP (₹)
CS1000-1600	PHL5	POR	PL5	POR

NOTE : Above mentioned products are non stockable.



WiNbreak2 MCCB

Features:

- Conforms to IS/IEC 60947-2
- Ics = 100% Icu
- Range: 16A-1600A, 3P & 4P*
- Breaking capacity: 50kA, 65kA, 70kA, 85kA & 150kA*
- Positive Isolation
- Trip Free Mechanism
- Double contact structure
- Communication compatible
- No Line-load Bias
- Neutral with 100% rated current
- Tripping by pressure
- Current limiting
- Manual, Rotary or Motorized available
- Wide range of internal & external accessories
- Standard packing includes spreaders terminals, insulating phase barriers and hardware



FMU (Thermal Magnetic) Release ● Adjustable Overload 80-100% [HSN Code: 8536]
● Fixed short circuit 10 In

Size	Rated Current (Amps)	Breaking capacity Icu at 415V AC	3 Pole Reference	MRP (₹)	4 Pole Reference	MRP (₹)
Frame 4	800	65kA	CS800NFMU*3P	85070	CS800NFMU*4P	113830

ATU (Thermal Magnetic) Release ● Adjustable Overload 80 - 100% [HSN Code: 8536]
● Adjustable Short circuit 5 - 10 In

Frame 4	800	65kA	CS800NATU*3P	95440	CS800NATU*4P	118340
---------	-----	------	--------------	-------	--------------	--------

ETS (Microprocessor based) Release ● Adjustable Overload 40 - 100% [HSN Code: 8536]
● Adjustable shortcircuit 1.5 - 10 In

Frame 4	800	65kA	CS800NETS*3P	102680	CS800NETS*4P	131010
---------	-----	------	--------------	--------	--------------	--------

ATU - *Rated Current (Amp) 300, 500 for 3 Pole & 4 Pole are non stockable items.

ETM (Microprocessor Release with in-built Earth fault Protection) [HSN Code: 8536]
● Adjustable Overload 40 - 100% ● Adjustable shortcircuit 1.5 - 10 In

Frame 4	800	65kA	CS800NE M43800A3PE	168580	CS800NETM43800A4PE	210730
---------	-----	------	--------------------	--------	--------------------	--------

NOTE :

1. While ordering replace *** by Current Rating
2. Spreader Terminals are not included MCCBs upto 63A
3. For 3 Pole ETM (Microprocessor) MCCB one Neutral CT will be required, if ground fault protection is required, for reference & MRP Please refer page 34.
4. MCCB with Ammeter, ZSI & communication feature is also available. For reference & MRP contact nearest Branch Office.
5. MCCB for Motor Backup Protection is also available. For prices contact nearest Branch Office.
6. *For other ratings contact nearest Branch Office.

Accessories [HSN Code: 8536]

Suitable for use on WB2 MCCBs	Shunt Trip (SHT)	MRP (₹)	Under Voltage Trip (UVT)	MRP (₹)	Auxiliary Switch (AX)	MRP (₹)	Alarm Switch (AL)	MRP (₹)	Fault Alarm Switch (FAL)*	MRP (₹)
CS800	ST-T(..V)	4990	UVT-T(..V)	6810	AX-T	2150	AL-T	2150	FAL-T	2150

NOTE :

1. FAL (Fault Alarm Switch)* It can be applied to only circuit breakers with electronic trip units
2. Maximum Possibilities for Internal Accessories

Voltage Selection UVT & Shunt

Size	AC	DC	AC / DC Common
UVT			
Frame 4	380~440V, 440~480V	-	24V, 48V, 110~130V, 200~240VAC/ 250VDC
Shunt			
Frame4	380~500V	12V	24V, 48V, 110~130V, 200~240VAC / 250VDC

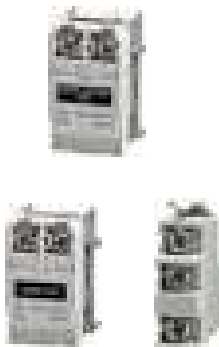

	Accessory	CS800
Left	AX	3
	AL	-
	SHT / UVT	1
Right	AX	-
	AL	2
	FAL	1

WiNbreak2 MCCB



Rotary Handle [HSN Code: 8538]

Suitable for use on WB2 MCCBs	Direct Rotary Handle	MRP (₹)	Direct Rotary Handle with Keylock	MRP (₹)	Extended Rotary Handle	MRP (₹)
CS800	<input checked="" type="checkbox"/> DH4-S	6870	<input checked="" type="checkbox"/> DHK4-S	8140	EH4-S	8900



Mechanical Interlock (Used to prevent mechanically closing together) [HSN Code: 8538]

Suitable for use on WB2 MCCBs	3 Pole Reference	MRP (₹)	4 Pole Reference	MRP (₹)
CS800	MIT43	17730	MIT44	18100



Motor Operator - For remote "ON/OFF" operation only [HSN Code: 8538]

Suitable for MCCB Type	Control Voltage	Reference	MRP (₹)
CS800	<input checked="" type="checkbox"/> 24V DC	MOP4(..V)	77800
	<input checked="" type="checkbox"/> AC110V/DC110V		
	AC230V/DC220V		

*Replace (...V) by require voltage.



Padlocking Device [HSN Code: 8538]

Suitable for use on WB2 MCCBs	Fixed Lock		Removable Lock	
	Reference	MRP (₹)	Reference	MRP (₹)
CS800	<input checked="" type="checkbox"/> PHL 4	3940	<input checked="" type="checkbox"/> PL 4	2090

NCT for WiNbreak2 ETM-Microprocessor (3 Pole MCCB if ground fault facility is required) [HSN Code: 8538]

Description	Reference	MRP (₹)
800/0.1A	NCT-WB2-080	11190

non stockable items.



WiNbreak MCCB - CSC Series

- Conforms to IS/IEC 60947-2
- Ics=100%Icu
- Range: 15A-1200A, 2, 3 & 4 Pole*
- Breaking capacity: 18kA, 26kA, 37kA, 50kA, 65kA & 85kA*
- Positive Isolation
- Trip free mechanism
- Wide range of Internal & External Accessories
- SS Enclosure available
- Standard packing includes insulating phase barriers and hardware



FTM (Thermal Magnetic) Release • Fixed Overload • Fixed short circuit [HSN Code: 8536]

Size	Rated Current (Amps)	Breaking capacity Icu at 415V AC	2 Pole Reference	MRP (₹)	3 Pole Reference	MRP (₹)	4 Pole Reference	MRP (₹)
Frame 5	700, 800	37kA	-	-	CSC6N3*	71970	☒CSC6N4*	85940
Frame 5	700, 800	65kA	-	-	CSC6S3*	77980	CSC6S4*	98700
Frame 5	700, 800	85kA	-	-	CSC6L3*	166020	CSC6L4*	186760

FTM (Thermal Magnetic) Release • Fixed Overload • Fixed short circuit • Ics=50%Icu [HSN Code: 8536]

Size	Rated Current (Amps)	Breaking capacity Icu at 415V AC	2 Pole Reference	MRP (₹)	3 Pole Reference	MRP (₹)	4 Pole Reference	MRP (₹)
Frame 6	1000◆	65kA	-	-	CSC7S3*	197470	☒CSC7S4*	247190
	1200◆		-	-	CSC8S3*	209910	CSC8S4*	250400
Frame 6	1000◆	85kA	-	-	CSC7L3*	252320	CSC7L4*	302310
	1200◆		-	-	CSC8L3*	293580	CSC8L4*	353340

- NOTES :**
1. While Ordering, Replace "*" by Current rating.
 2. ◆Spreader Terminals are included as standard packing.
 3. # For other ratings contact to nearest Branch Office.

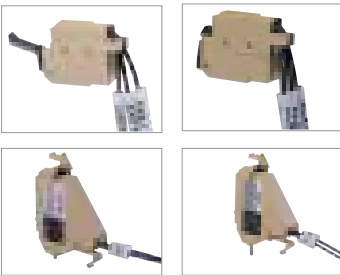

Accessories [HSN Code: 8538]

Suitable for use on WB-CSC MCCBs	Shunt Trip (SHT)	MRP (₹)	Under Voltage Trip (UVT)	MRP (₹)	Auxiliary Switch (AX)	MRP (₹)	Alarm Switch (AL)	MRP (₹)	Combination Switch (AX + AL)	MRP (₹)
CSC7, CSC8	ST-7A(...V)	14910	UVT-7A(...V)	14910	ASW-7A	5280	ALSW-7A	5050	-	-

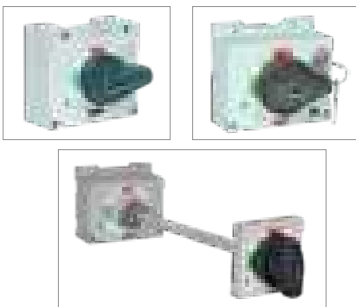

Rotary Handle [HSN Code: 8538]

Suitable for use on WB-CSC MCCBs	Direct Rotary Handle	MRP (₹)	Direct Rotary Handle with Key Lock	MRP (₹)	Extended Rotary Handle	MRP (₹)
CSC6		-		-	E80U	7680

- NOTES:**
1. Please replace "*" with R as MCCB left hand side position & T as MCCB right hand position.
 2. Left Hand seat is not available in 2 Pole MCCB in Frame 1 & Frame 2
 3. Rotary Handle for 2 Pole Frame 1 & Frame 2 is not available.

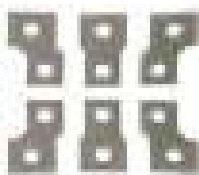

Spreader Terminals [HSN Code: 8538]

Suitable for use on MCCBs	Pole	Current Rating (A)	Reference	MRP (₹)	MOQ
CSC6	3 Pole	700, 800	CSET8033	3860	Set of 3
CSC6	4 Pole	700, 800	CSET8044	4710	Set of 4

SS Enclosure for WB MCCB [HSN Code: 8538]

Size	Suitable for use on MCCBs	3 Pole Reference*	4 Pole Reference*	MRP (₹)
Frame 6	CSC7, CSC8	☒CS-CNM0100204	-	13200

- NOTES:**
- 1) *Reference code is for Enclosure only (without MCCB)
 - 2) For placing an order for MCCB along with Enclosure, please apply Prefix E- before MCCB Reference Code. For Price please contact nearest Branch Office.

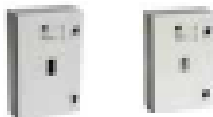



Switch Disconnectors at a Glance

NON MODULAR RANGE



D Type



K Type



NM Type



DM Type



K Type



P Type

MODULAR RANGE



Switch Disconnecter Fuse Unit

Switch Disconnecter Fuse Unit (without Fuse Links)

- Conforms to IS/IEC 60947-3
- Range: 32-800A, 415V AC 50Hz
- Door Interlock and Padlock facility
- Version: 2P / TP / TPN / 4P
- Modular Construction
- Positive Isolation
- Suitable for DIN & Bolted HRC Fuse Links



[HSN Code: 8537]

Size	Rating Amps	Pole	CSSDF in Open Execution				CSSDF in Sheet Steel Enclosure				Recommended Fuse Links Type (IEC Size)	
			Reference	MRP (₹)	Reference	MRP (₹)	Reference	MRP (₹)	Reference	MRP (₹)	DIN	BS
			DIN		BS		DIN		BS			
Frame 1	32A	2P	CSSDF32D2	2830	CSSDF32B2	3430					CDFL00 32	CTIA-32(A2)
		TP	CSSDF32D3	3380	CSSDF32B3	3520	☒E-CSSDF32D3	6480	E-CSSDF32B3	6730		
		TPN	CSSDF32D3N	3610	CSSDF32B3N	3620	E-CSSDF32D3N	6730	E-CSSDF32B3N	6860		
		4P	☒CSSDF32D4FN	4160	☒CSSDF32B4FN	3920	E-CSSDF32D4FN	7330	☒E-CSSDF32B4FN	7440		
Frame 1	63A	2P	CSSDF63D2	4160	CSSDF63B2	3990					CDFL00 63	CSTIS-63(A3)
		TP	CSSDF63D3	4340	CSSDF63B3	4280	☒E-CSSDF63D3	7660	E-CSSDF63B3	7730		
		TPN	CSSDF63D3N	4410	CSSDF63B3N	4600	E-CSSDF63D3N	8280	E-CSSDF63B3N	8410		
		4P	CSSDF63D4FN	4840	CSSDF63B4FN	5000	E-CSSDF63D4FN	8620	☒E-CSSDF63B4FN	8640		
Frame 2	100A	2P	CSSDF100D2	7210	CSSDF100B2	8330					CDFL00 100	CTCP-100(A4)
		TP	CSSDF100D3	8730	CSSDF100B3	9610	E-CSSDF100D3	12830	E-CSSDF100B3	13130		
		TPN	CSSDF100D3N	9330	CSSDF100B3N	9780	E-CSSDF100D3N	13630	E-CSSDF100B3N	13240		
		4P	CSSDF100D4FN	10990	☒CSSDF100B4FN	11620	E-CSSDF100D4FN	15510	☒E-CSSDF100B4FN	16180		
Frame 2	125A	2P	CSSDF125D2	8740	CSSDF125B2	8880					CDFL00 125	CTCP-125(A4)
		TP	CSSDF125D3	9330	☒CSSDF125B3	9690	☒E-CSSDF125D3	14720	E-CSSDF125B3	14530		
		TPN	CSSDF125D3N	10260	CSSDF125B3N	10480	E-CSSDF125D3N	15300	E-CSSDF125B3N	16370		
		4P	CSSDF125D4FN	12730	CSSDF125B4FN	12720	☒E-CSSDF125D4FN	16730	☒E-CSSDF125B4FN	17360		
Frame 2	160A	2P	☒CSSDF160D2	10650	CSSDF160B2	10990					CDFL00 160	CTF-160(B2)
		TP	CSSDF160D3	11840	☒CSSDF160B3	12230	E-CSSDF160D3	16650	E-CSSDF160B3	16850		
		TPN	CSSDF160D3N	12050	CSSDF160B3N	13490	E-CSSDF160D3N	17940	☒E-CSSDF160B3N	18580		
		4P	☒CSSDF160D4FN	14360	☒CSSDF160B4FN	15900	E-CSSDF160D4FN	22300	E-CSSDF160B4FN	24600		
Frame 3	200A	2P	CSSDF200D2	13000	CSSDF200B2	13680					CDFL1 200 / CSDFL1 200	CTF-200(B2)
		TP	CSSDF200D3	14080	☒CSSDF200B3	14750	☒E-CSSDF200D3	19190	E-CSSDF200B3	22840		
		TPN	CSSDF200D3N	15830	CSSDF200B3N	15830	E-CSSDF200D3N	20770	E-CSSDF200B3N	24040		
		4P	CSSDF200D4FN	16820	CSSDF200B4FN	18110	☒E-CSSDF200D4FN	24020	E-CSSDF200B4FN	25260		
Frame 3	250A	2P	CSSDF250D2	14760	☒CSSDF250B2	15220					CDFL1 250/ CSDFL1 250	CTKF250(B3)
		TP	CSSDF250D3	17090	CSSDF250B3	17550	☒E-CSSDF250D3	22290	E-CSSDF250B3	24040		
		TPN	CSSDF250D3N	17160	CSSDF250B3N	17760	E-CSSDF250D3N	23190	E-CSSDF250B3N	24750		
		4P	CSSDF250D4FN	19260	CSSDF250B4FN	19750	☒E-CSSDF250D4FN	26980	E-CSSDF250B4FN	27580		
Frame 3	315A	2P	CSSDF315D2	17360	CSSDF315B2	18210					CDFL2 315/ CSDFL2 315	CTKF-315(B3)
		TP	CSSDF315D3	22180	CSSDF315B3	22460	E-CSSDF315D3	27720	E-CSSDF315B3	29130		
		TPN	CSSDF315D3N	22840	CSSDF315B3N	22920	E-CSSDF315D3N	28020	E-CSSDF315B3N	29370		
		4P	CSSDF315D4FN	26340	CSSDF315B4FN	24900	☒E-CSSDF315D4FN	36700	E-CSSDF315B4FN	39640		
Frame 3	400A	2P	☒CSSDF400D2	22380	CSSDF400B2	23240					CDFL2 400/ CSDFL2 400	CTMF-400(B4)
		TP	CSSDF400D3	26550	☒CSSDF400B3	27890	☒E-CSSDF400D3	33890	E-CSSDF400B3	35340		
		TPN	CSSDF400D3N	27350	CSSDF400B3N	28210	E-CSSDF400D3N	34140	E-CSSDF400B3N	35580		
		4P	CSSDF400D4FN	30520	CSSDF400B4FN	33060	☒E-CSSDF400D4FN	38690	E-CSSDF400B4FN	42610		
Frame 4	630A	2P	CSSDF630D2	37890	☒CSSDF630B2	33740					CDFL3 630	CTTM-630(C2)
		TP	CSSDF630D3	46540	☒CSSDF630B3	47880	E-CSSDF630D3	49860	E-CSSDF630B3	55300		
		TPN	CSSDF630D3N	48080	CSSDF630B3N	48480	E-CSSDF630D3N	52420	☒E-CSSDF630B3N	59710		
		4P	CSSDF630D4FN	53250	CSSDF630B4FN	57130	☒E-CSSDF630D4FN	63890	E-CSSDF630B4FN	67980		
Frame 4	800A	2P	CSSDF800D2	50580	CSSDF800B2	47060					-	CTLM-800(C3)
		TP	☒CSSDF800D3	55070	CSSDF800B3	59620	E-CSSDF800D3	POR	E-CSSDF800B3	POR		
		TPN	CSSDF800D3N	56490	CSSDF800B3N	62510	☒E-CSSDF800D3N		☒E-CSSDF800B3N			
		4P	☒CSSDF800D4FN	64820	CSSDF800B4FN	70620	E-CSSDF800D4FN					

☒ non stockable items.

Accessories Switch Disconnectors Fuse Unit



Key Interlocks (3 Locks - 2 Keys)		[HSN Code: 8538]
For Switch Type	Reference	MRP (₹)
CSSDF 32A - 160A	<input checked="" type="checkbox"/> CSSDFZW-16	5690
CSSDF 200A - 800A	CSSDFZW-5	6380



Castle Key Locks		[HSN Code: 8538]
CSSDF 32A - 160A	CSSDFZW-15	7290
CSSDF 200A - 800A	CSSDFZW-4	7670



Auxiliary Contacts		[HSN Code: 8538]
1 NO + 1 NC CSSDF 32A - 63A for 3P	CSSDFZX46	970
2 NO + 2 NC CSSDF 32A - 63A for 3P	CSSDFZX32	1780
1 NO + 1 NC CSSDF 32A - 63A for 2P & 4P	CSSDFZX46B	970
2 NO + 2 NC CSSDF 32A - 63A for 2P & 4P	<input checked="" type="checkbox"/> CSSDFZX32B	1780
1 NO + 1 NC CSSDF 100A - 160A	CSSDFZX1	970
2 NO + 2 NC CSSDF 100A - 160A	<input checked="" type="checkbox"/> CSSDFZX16	1780
1 NO + 1 NC CSSDF 200A - 400A	CSSDFZX33	1170
2 NO + 2 NC CSSDF 200A - 400A	CSSDFZX34	2160
1 NO + 1 NC CSSDF 630A - 800A	CSSDFZX35	1170
2 NO + 2 NC CSSDF 630A - 800A	<input checked="" type="checkbox"/> CSSDFZX36	1780



Handle Mounting Kit (for independent mounting of O/E Switches)		[HSN Code: 8538]
CSSDF 200A - 400A	HMK-1-2	2480
CSSDF 630A - 800A	HMK-3-2	2620



Extended Terminals						[HSN Code: 8538]
32A-63A	TPN	ET-323	640	4P	ET-324	770
100A-160A	TPN	ET-327	1600	4P	ET-328	2280
200A-400A	TPN	ET-329	4670	4P	ET-330	5690

non stockable items.



Switch Disconnecter

Switch Disconnectors (Load Break Switches)

- Conforms to IS/IEC 60947-3
- Range: 25A-400A, 415V AC 50Hz
- Version: TP / 4P
- Compact Construction
- Door Interlock and Padlock facility
- Positive Isolation



[HSN Code: 8536]

Size	Rating Amps	Pole	CSSD In Open Execution		In Sheet Steel Enclosure	
			Reference	MRP (₹)	Reference	MRP (₹)
D-Series	25	3	CSSD25D3	2430	☒E-CSSD25D3	5290
		4	☒CSSD25D4	3210	E-CSSD25D4	5760
	40	3	CSSD40D3	2600	E-CSSD40D3	6090
		4	CSSD40D4	5040	☒E-CSSD40D4	6650
	63	3	CSSD63K3	3450	☒E-CSSD63K3	7260
	63	4	CSSD63D4	5510	☒E-CSSD63D4	8720
NM-Series	125	3	CSSD125D3	7740	E-CSSD125D3	12180
		4	CSSD125D4	9410	☒E-CSSD125D4	13520
	125	3	CSSD125NM3	9080	E-CSSD125NM3	13410
		4	CSSD125NM4	11190	E-CSSD125NM4	16560
	160	3	☒CSSD160NM3	10120	E-CSSD160NM3	14970
		4	☒CSSD160NM4	12040	E-CSSD160NM4	17850
	200	3	☒CSSD200NM3	12930	E-CSSD200NM3	16790
		4	CSSD200NM4	16760	E-CSSD200NM4	21790
	250	3	CSSD250NM3	13080	E-CSSD250NM3	19350
		4	CSSD250NM4	18130	☒E-CSSD250NM4	26870
315	3	CSSD315NM3	17040	E-CSSD315NM3	POR	
	4	CSSD315NM4	18390	E-CSSD315NM4	POR	
400	3	CSSD400NM3	20420	E-CSSD400NM3	POR	
	4	CSSD400NM4	24780	E-CSSD400NM4	POR	

NOTE:

- Rotary Handle with door defeat Mechanism handle is available only for 25-125A (D&K Type).
- Pistol Handle is available for complete range.
- Switch Disconnecter with Direct Handle and Extended Terminals are also available. Please contact nearest Branch Office for prices.
- Handle Colour: Red knob & yellow base is available on request for rotary switches upto 125A.



Switch Disconnecter

Switch Disconnectors (Load Break Switches)

- Conforms to IS/IEC 60947-3
- Range: 125A-3150A, 415V, 50Hz
- Version: 2P, 3P, 4P
- Modular construction
- Positive Isolation
- Door Interlock and Padlock facility ■



Size	Rating Amps	Pole	CSSD In Open Execution [HSN Code: 8536]		In Sheet Steel Enclosure [HSN Code: 8536]		
			Reference	MRP (₹)	Reference	MRP (₹)	
DM-Series	125	3	CSSD125DM3	10170	E-CSSD125DM3	13740	
		4	CSSD125DM4	12600	☒E-CSSD125DM4	17010	
	160	3	CSSD160DM3	11640	E-CSSD160DM3	15380	
		4	CSSD160DM4	13460	E-CSSD160DM4	18490	
	200	3	CSSD200DM3	14430	E-CSSD200DM3	19630	
		4	CSSD200DM4	21440	E-CSSD200DM4	25520	
	250	3	CSSD250DM3	17590	E-CSSD250DM3	23190	
		4	CSSD250DM4	21750	E-CSSD250DM4	27120	
	315	3	CSSD315DM3	20420	E-CSSD315DM3	25370	
		4	CSSD315DM4	24830	E-CSSD315DM4	29490	
	400	3	CSSD400DM3	24750	E-CSSD400DM3	30070	
		4	CSSD400DM4	28870	E-CSSD400DM4	35620	
	K-Series	630	3	CSSD630K3	36680	E-CSSD630K3	42940
			4	CSSD630K4	43020	E-CSSD630K4	49890
800		3	CSSD800K3	43300	E-CSSD800K3	50220	
		4	CSSD800K4	47740	E-CSSD800K4	60420	
P-Series	1000	3	CSSD1000SB3	44250	E-CSSD1000SB3	72750	
		4	CSSD1000SB4	63090	E-CSSD1000SB4	95700	
	1000	3	☒CSSD1000P3	49380	E-CSSD1000P3	81170	
		4	☒CSSD1000P4	70390	E-CSSD1000P4	106780	
	1250	3	☒CSSD1250P3	73160	E-CSSD1250P3	99490	
		4	☒CSSD1250P4	96680	E-CSSD1250P4	130870	
	1600	3	☒CSSD1600P3	91620	E-CSSD1600P3	124600	
		4	☒CSSD1600P4	122150	E-CSSD1600P4	166130	
	2000	3	CSSD2000P3	183330	E-CSSD2000P3	240580	
		4	CSSD2000P4	208270	E-CSSD2000P4	268730	
	2500	3	CSSD2500P3	205050	E-CSSD2500P3	266990	
		4	CSSD2500P4	233020	E-CSSD2500P4	298270	
	3150	3	CSSD3150P3	258760	E-CSSD3150P3	358040	
		4	CSSD3150P4	294040	E-CSSD3150P4	415770	

NOTES:

'K' series from 1000A to 3150A in open execution & with enclosure is also available on special request for retrofit orders only. For price, please contact nearest Branch Office.

☒ non stockable items.



Switch Disconnecter

Switch Disconnectors (Moulded Construction)



Accessories							[HSN Code: 8538]	
For Switch Type			Reference		MRP (₹)			
Key Interlocks (3 Locks - 2 Keys)								
CSSD 125A-160A			CSSDZW - 16		7650			
CSSD 200A-3150A			CSSDZW - 5					
Castle Key Locks								
CSSD 25A-160A			CSSDZW - 15		6440			
CSSD 200A-3150A			CSSDZW - 4					
Auxiliary Contacts			Pole	Reference				
1 NO+1 NC CSSD 25A-40A			3P	☒CSSDZX49	1000			
2 NO+2 NC CSSD 25A-40A			3P	☒CSSDZX50	1890			
1 NO+1 NC CSSD 25A-40A			4P	CSSDZX87	1000			
2 NO+2 NC CSSD 25A-40A			4P	☒CSSDZX88	1890			
1 NO+1 NC CSSD 63A (K Type)			3P	☒CSSDZX79	1000			
2 NO+2 NC CSSD 63A (K Type)			3P	☒CSSDZX80	1890			
1 NO+1 NC CSSD 63~125A (D Type)			3P	☒CSSDZX52	1000			
2 NO+2 NC CSSD 63~125A (D Type)			3P	☒CSSDZX53	1890			
1 NO+1 NC CSSD 63A-125A			4P	☒CSSDZX55	1000			
2 NO+2 NC CSSD 63A-125A			4P	☒CSSDZX56	1890			
1 NO+1 NC CSSD 125A-160A (DM)			3/4P	☒CSSDZX1	1890			
2 NO+2 NC CSSD 125A-160A (DM)			3/4P	CSSDZX16				
1 NO+1 NC CSSD 200A-400A (DM)			3/4P	CSSDZX37				
2 NO+2 NC CSSD 200A-400A (DM)			3/4P	CSSDZX38				
1 NO+1 NC CSSD 630A-800A			3/4P	☒CSSDZX33				
2 NO+2 NC CSSD 630A-800A			3/4P	☒CSSDZX34				
1 NO+1 NC CSSD 1000A-3150A			3/4P	CSSDZX35				
2 NO+2 NC CSSD 1000A-3150A			3/4P	☒CSSDZX36				
Handle Mounting Kit (for independent mounting of O/E Switches)								
CSSD 200A-400A (DM Type)			HMK-2				2490	
CSSD 630A-800A			HMK-1-1		2520			
CSSD 1000A-1600A			HMK-3-1		2690			
Extended Terminals	Pole	Reference	MRP (₹)	Pole	Reference	MRP (₹)		
125A	3P	ET-325	900	4P	ET-326	970		
100A-160A	3P	ET-327	1600	4P	ET-328	2280		
200A-400A	3P	ET-329	4670	4P	ET-330	5690		
Rotary Knob Handles								
CSSD 25A-125A (Moulded-Red/Yellow)			☒CSSDZX108		620			
CSSD 25A-125A (Moulded-Black)			CSSDZX111BL					
Switch Handles								
CSSD 400A-800A (K Type)			CSWH145S12		1760			
CSSD 1000A-1600A (Moulded)			CSWH220S12		2250			
CSSD 2500A-3150A (Metallic)			CSDA8		2650			
CSSD 125A-160A (DM Type)			CSWH80S6		1020			
CSSD 200A-400A (DM Type)			☒CSWH80S8					
Switch Handle Shaft								
CSSD 25A-125A			☒CSP5X70		700			
CSSD 125A-160A (DM)			CAP6X165		450			
CSSD 200A-400A (DM)			☒CSP8X240					
CSSD 630A-1600A			CSP12X255		790			
CSSD 2500A-3150A			CSP12X325		960			



Changeover Switch

On Load Changeover Switches

- Conforms to IS/IEC 60947-3
- Range: 63A–3150A, 415V, 50Hz
- Version: 4P
- Modular construction
- Positive Isolation
- Door Interlock and Padlock facility ■



In Open Execution

[HSN Code: 8536]

Size	Rating (Amps)	Pole	Reference	MRP (₹)	
NM-Series	Frame 1	63	4	CSCS63NM4CO	8560
	Frame 1	100	4	CSCS100NM4CO	11370
	Frame 2	125	4	CSCS125NM4CO	16610
	Frame 2	160	4	CSCS160NM4CO	18260
	Frame 2	200	4	CSCS200NM4CO	21960
	Frame 2	250	4	CSCS250NM4CO	32960
DM-Series	Frame 2	315	4	CSCS315DM4CO	34350
	Frame 2	400	4	CSCS400DM4CO	50340
K-Series	Frame 3	630	4	CSCS630K4CO	58740
	Frame 3	800	4	CSCS800K4CO	83570
P-Series	Frame 4	1000	4	CSCS1000SB4CO	133060
	Frame 4	1000	4	CSCS1000P4CO	148460
	Frame 4	1250	4	CSCS1250P4CO	200710
	Frame 4	1600	4	CSCS1600P4CO	254200
	Frame 5	2000	4	CSCS2000P4CO	367330
	Frame 5	2500	4	CSCS2500P4CO	486630
	Frame 5	3150	4	CSCS3150P4CO	670660

In Sheet Steel Enclosure

[HSN Code: 8536]

Size	Rating (Amps)	Pole	Reference	MRP (₹)	
NM-Series	Frame 1	63	4	E-CSCS63NM4CO	12040
	Frame 1	100	4	E-CSCS100NM4CO	15150
	Frame 2	125	4	E-CSCS125NM4CO	22100
	Frame 2	160	4	E-CSCS160NM4CO	24050
	Frame 2	200	4	E-CSCS200NM4CO	27830
	Frame 2	250	4	E-CSCS250NM4CO	42090
DM-Series	Frame 2	315	4	E-CSCS315DM4CO	43480
	Frame 2	400	4	E-CSCS400DM4CO	64030
K-Series	Frame 3	630	4	E-CSCS630K4CO	73720
	Frame 3	800	4	E-CSCS800K4CO	109950
P-Series	Frame 4	1000	4	E-CSCS1000SB4CO	171680
	Frame 4	1000	4	E-CSCS1000P4CO	191560
	Frame 4	1250	4	E-CSCS1250P4CO	248550
	Frame 4	1600	4	E-CSCS1600P4CO	323250
	Frame 5	2000	4	E-CSCS2000P4CO	456280
	Frame 5	2500	4	E-CSCS2500P4CO	583850
	Frame 5	3150	4	E-CSCS3150P4CO	791380

NOTES:

1. 'K' series from 1000A to 3150A in open execution & with enclosure is also available on special request for retrofit orders only. For price, please contact nearest Branch Office. ■ Upto 800A
2. NM Series is of non-modular type.

ACCESSORIES

Auxiliary Contacts for NM Type Changeover

Description	Reference	MRP (₹)
1NO +1NC for 63–100A	CSCONM1AUX10	860
1NO +1NC for 125–250A	CSCONM2AUX10	

non stockable items.

Bypass Switches

LT Bypass Switch complete with Handle Assembly having Door Interlock and Padlocking arrangement.

In Open Execution				[HSN Code: 8536]
Size	Rating (Amps)	Pole	Reference	MRP (₹)
Frame 1	63	4	CSBS63DM4	23030
	80	4	CSBS80DM4	28120
	100	4	CSBS100DM4	29330
	125	4	CSBS125DM4	32270
	160	4	CSBS160DM4	38150
Frame 2	200	4	CSBS200DM4	38990
	250	4	CSBS250DM4	59350
	315	4	CSBS315DM4	61600
	400	4	CSBS400DM4	87000
Frame 3	630	4	CSBS630K4	104090
	800	4	CSBS800K4	130560
Frame 4	1000	4	CSBS1000P4	243500
	1250	4	CSBS1250P4	334420
	1600	4	CSBS1600P4	448710

In Sheet Steel Enclosure				[HSN Code: 8536]
Size	Rating (Amps)	Pole	Reference	MRP (₹)
Frame 1	63	4	E-CSBS63DM4	32780
	80	4	E-CSBS80DM4	35100
	100	4	E-CSBS100DM4	36020
	125	4	E-CSBS125DM4	41040
	160	4	E-CSBS160DM4	44290
Frame 2	200	4	E-CSBS200DM4	50090
	250	4	E-CSBS250DM4	72000
	315	4	E-CSBS315DM4	77030
	400	4	E-CSBS400K4	107780
Frame 3	630	4	E-CSBS630K4	123230
	800	4	E-CSBS800K4	182550
Frame 4	1000	4	E-CSBS1000P4	300690
	1250	4	E-CSBS1250P4	405950
	1600	4	E-CSBS1600P4	546230

NOTES:

'K' series from 1000A to 1600A is also available on request for retrofit only. For price, please contact nearest Branch Office. Door interlock & Pad locking arrangements are available upto 800A

Bypass Switches

LT Bypass Switch complete with Handle Assembly having Door Interlock and Padlocking arrangement.

Accessories for Changeover -Type DM/K/P

Auxiliary Contacts				[HSN Code: 8538]
Contacts Configuration	For Switch Type	Qty./Switch	Reference	MRP (₹)
1NO+1NC	CSCS/CSBS 63A-160A Upper CSCF 125A-160A	1	☒CSCSZX1-U	950
1NO+1NC	CSCS/CSBS 63A-160A Lower CSCF 125A-160A	1	☒CSCSZX1-L	950
2NO+2NC	CSCS/CSBS 63A-160A Upper CSCF 125A-160A	1	☒CSCSZX3-U	1850
2NO+2NC	CSCS/CSBS 63A-160A Lower CSCF 125A-160A	1	CSCSZX3-L	1850
1NO+1NC	CSCS/CSBS 200A-1600A CSCF 200A-800A	2	CSCSZX2	1900
2NO+2NC	CSCS/CSBS 200A-1600A CSCF 200A-800A	2	CSCSZX4	3680

Bypass Switch application

Table of Operation

Handle	Switch-I	Switch-II	Switch-III	Remarks
Position-I	ON	OFF	ON	Regulated Supply to Load
Position-O	OFF	OFF	OFF	No Supply, Load as well as Regulator Isolated form incoming source
Position-II	OFF	ON	OFF	Direct Supply, Regulator By-passed & Isolated

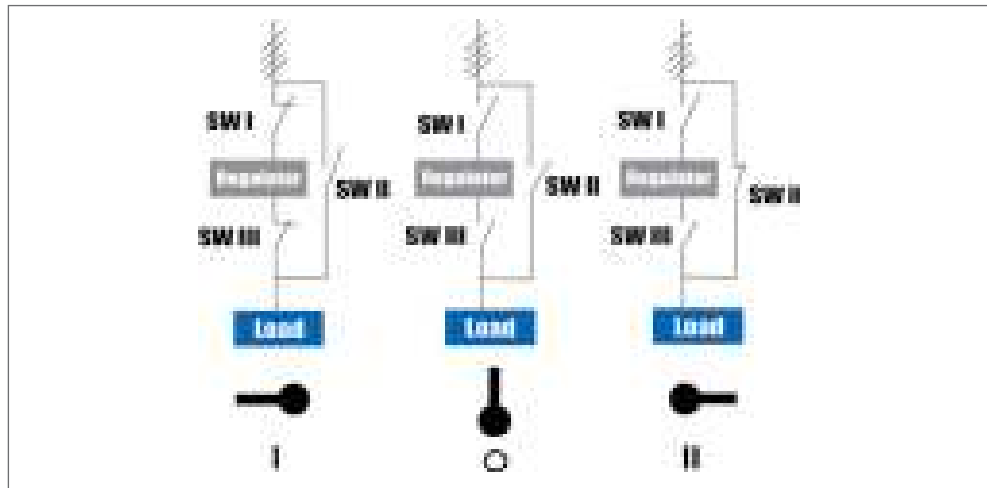

Switch Disconnector Fuse Changeover (Conventional Type / Side-by-Side)

LT Heavy Duty 4 Pole Changeover Switch Disconnector Fuse unit comprising of two Switches, 32A - 800A, 415V, 50Hz mounted on common chassis complete with Mechanical Interlock and Handle Assembly having Door Interlock & Padlocking arrangements.

CSSDF in Open Execution, 4 Pole				[HSN Code: 8536]
Size	Rating (Amps)	Reference		MRP (₹)
		DIN	BIS	
Frame 1	32	CSSDF32D4CO	CSSDF32B4CO	POR
	63	CSSDF63D4CO	CSSDF63B4CO	
Frame 2	100	CSSDF100D4CO	CSSDF100B4CO	
	125	CSSDF125D4CO	CSSDF125B4CO	
	160	CSSDF160D4CO	CSSDF160B4CO	
Frame 3	200	☒ CSSDF200D4CO	CSSDF200B4CO	
	250	☒ CSSDF250D4CO	CSSDF250B4CO	
	315	☒ CSSDF315D4CO	CSSDF315B4CO	
	400	☒ CSSDF400D4CO	CSSDF400B4CO	
Frame 4	630	☒ CSSDF630D4CO	CSSDF630B4CO	
	800	-	CSSDF800B4CO	

Load Break Changeover Conventional Type / Side-by-Side)

LT Heavy Duty 4 Pole Changeover Load Break Switch comprising of two Switches 25A - 3150A, 415V, 50Hz mounted on common chassis complete with Mechanical Interlock and Handle Assembly having Door Interlock and Padlocking arrangements.

CSSD in Open Execution, 4 Pole			[HSN Code: 8536]
Size	Rating (Amps)	Reference	MRP (₹)
Frame 1	25	CSSD25D4CO	POR
	40	CSSD40D4CO	
Frame 2	63	CSSD63D4CO	
Frame 3	125	☒ CSSD125DM4CO	
	160	☒ CSSD160DM4CO	
Frame 4	200	☒ CSSD200DM4CO	
	250	☒ CSSD250DM4CO	
	400	☒ CSSD400DM4CO	
Frame 5	630	☒ CSSD630K4CO	
	800	☒ CSSD800K4CO	
Frame 6	1000	☒ CSSD1000P4CO	
	1250	☒ CSSD1250P4CO	
	1600	☒ CSSD1600P4CO	
Frame 7	1800	☒ CSSD1800P4CO	
	2500	☒ CSSD2500P4CO	
	3150	☒ CSSD3150P4CO	

NOTE:

- Shorting Links/ Busbars NOT provides with open execution in conventional type Changeover Switches Enclosure Prices on request.
- 'K' series from 1000A to 3150A in open execution is also available on special request for retrofit jobs only. For price, please contact nearest Branch Office.



RoHS
Compliant

ATS

Automatic / Motorized Transfer Switch

Key Features:

- With inbuilt micro processor based AMF controller
- Protection against under/over voltage, Single phase missing
- External indication terminal output for Source healthy and load ON
- Inbuilt fuse protection to avoid failure of AMF controller
- 3 Position isolation lock for Source I - Off - Source II

Applications:

- Airports & Railways
- IT, Malls and Commercial buildings
- Automobile Industries
- Data Centre and Telecommunications
- Oil and Gas Industries
- Manufacturing Industries
- Healthcare
- Banking & Finance



Automatic Transfer Switch

- Confirms IEC-60947-6-1
- Range 40A-3200A
- Utilization Category AC32B

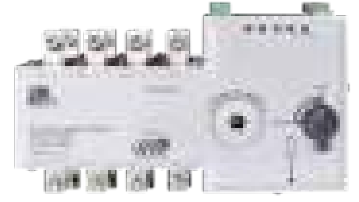

Automatic Transfer Switch

[HSN Code: 8536]

Size	Rating	Pole	Reference	MRP (₹)
Frame-1	40A	4	CATS1F40A ■	65560
	63A	4	CATS1F63A ■	67080
Frame-2	100A	4	CATS2F100A ■	70230
	125A	4	CATS2F125A ■	74880
Frame-3	160A	4	CATS3F160A ■	80320
Frame-4	200A	4	CATS4F200A ■	107140
	250A	4	CATS4F250A ■	114720
Frame-5	315A	4	CATS5F315A ■	135280
	400A	4	CATS5F400A ■	136910
	630A	4	CATS5F630A ■	178240
Frame-6	800A	4	CATS6F800A ■	333790
	1000A	4	CATS6F1000A ■	347110
	1250A	4	CATS6F1250A ■	362410
	1600A	4	CATS6F1600A ■	476850
Frame-7	2000A	4	CATS7F2000A ■	705750
	2500A	4	CATS7F2500A ■	915560
	3200A	4	CATS7F3200A ■	1133000

NOTE: While ordering replace ■ with 'T' (Top Incoming, Bottom Outgoing) 'B' (Bottom Incoming, Top Outgoing)

Ordering Information

CATS	1F	40A	-	-
Series	Frame Size 1F-Frame1 2F-Frame2 3F-Frame3 4F-Frame4 5F-Frame5 6F-Frame6 7F-Frame7	Current Rating 40A, 63A, 80A 100A, 125A 160A 200A, 250A 315A, 400A, 630A 800A, 1000A, 1250A, 1600A 2000A, 2500A, 3200A	↓ T (Top Incoming, Bottom Outgoing)	↓ B (Bottom Incoming, Top Outgoing)

Motorised Transfer Switch - Remotely operated

[HSN Code: 8536]

Size	Rating	Pole	Reference	MRP (₹)
Frame-1	40A	4	CMTS1F40A	39340
	63A	4	CMTS1F63A	40250
Frame-2	100A	4	CMTS2F100A	42140
	125A	4	CMTS2F125A	59900
Frame-3	160A	4	CMTS3F160A	64250
Frame-4	200A	4	CMTS4F200A	85720
	250A	4	CMTS4F250A	91770
Frame-5	315A	4	CMTS5F315A	128510
	400A	4	CMTS5F400A	130060
	630A	4	CMTS5F630A	169330
Frame-6	800A	4	CMTS6F800A	271810
	1000A	4	CMTS6F1000A	272790
	1250A	4	CMTS6F1250A	302610
	1600A	4	CMTS6F1600A	380520
Frame-7	2000A	4	CMTS7F2000A	597980
	2500A	4	CMTS7F2500A	779170
	3200A	4	CMTS7F3200A	960380

HRC Fuse Link, Fuse Base & Fuse Holder

Range: 2A-800A

- Conforms to IS/IEC 60269-Part 2
- Range: DIN type (6-630A), 500V, AC 50Hz, Bolted type (2-800A), 415V, AC 50Hz
- High breaking capacity: 80kA



DIN Type HRC Fuse Link				[HSN Code: 8536]
IS/IEC Size	In A	Reference	MRP (₹)	Std. Pkg. (Nos)
00	6, 10, 16, 20, 25, 32, 35	CDFL00*	450	3
	40, 50, 63	CDFL00*	450	
	80, 100	CDFL00*	460	
	125, 160	CDFL00*	470	
1	32, 35, 50, 63	CDFL01*	790	
	80, 100, 125	CDFL01*	860	
	160	CDFL01*	860	
	200	CDFL1*	880	
	250	CDFL1*	960	
2	100, 125	CDFL02*	1240	
	160, 200	CDFL02*	1260	
	250	CDFL02*	1260	
	315	CDFL2*	1330	
3	400	CDFL2*	1390	
	315, 400	CDFL03*	1770	
	500	CDFL3*	2130	
	630	CDFL3*	2130	

While ordering, replace "*" by current rating.
For ISI version please contact nearest Branch Office.







Fuse Bases for DIN Type Fuse Link (ISI Mark)				[HSN Code: 8536]
IS/IEC Size	In A	Reference	MRP (₹)	Std. Pkg. (Nos)
00	160	CSDFB00	540	3
1	250	CSDFB1	970	
2	400	CSDFB2	1440	
3	630	CDFB3	2350	



Solid Link				[HSN Code: 8536]
IS/IEC Size	In A	Reference	MRP (₹)	Std. Pkg. (Nos)
00	160	CDSL00	660	3
1	250	CDSL1	880	
2	400	☒CDSL2	1210	
3	630	☒CDSL3	1480	

Bolted Type HRC Fuse Link



Off Set TAG Type				[HSN Code: 8536]
IS/IEC Size	Rating (Amps)	Reference	MRP (₹)	Std. Pkg. (Nos)
A1	2, 4, 6, 8, 10, 12 & 16	CNITE* 	100	20
	20, 25, & 32	CNITE* 		
A2	4, 6, 10, 16, 20, 25 & 32	CTIAE* 	150	20
A3	32, 40, 50 & 63	CTISE* 	210	10
A4	50, 63, 80, 100, 125	CTCP*	430	6
-	125, 160, 200	CTFP*	620	6

☒ CNS (Off Set) clip in Type				[HSN Code: 8536]
IS/IEC Size	In A	Reference	MRP (₹)	Std. Pkg. (Nos)
F1	2, 4, 6, 8, 10, 12, 16	CNSE*	100	20
F1	20, 25, 32	CNSE*	100	20

☒ non stockable items

Bolted Type HRC Fuse Link



Central TAG (2 hole fixing) Type				[HSN Code: 8536]
IS/IEC Size	In A	Reference	MRP (₹)	Std. Pkg. (Nos)
B1	80, 100	CTC*	460	6
B1	125	CTC*	460	
B2	125, 160, 200	CTF*	670	6
B3	250, 300, 315	CTKF*	970	1
B4	355, 400	CTMF*	1880	





☒ non stockable items.

HRC Fuse Link, Fuse Base & Fuse Holder



Central TAG (4 Hole Fixing) Type				[HSN Code: 8536]
IS/IEC Size	In A	Reference	MRP (₹)	Std. Pkg. (Nos)
C1	355, 400	☒CTM*	1800	1
C2	450, 500	☒CTTM*	2970	
C2	630	CTTM*	3840	
C3	670, 710, 750, 800	☒CTLM*	4090	



Cylindrical HRC Fuse Link				[HSN Code: 8536]
IS/IEC Size	In A	Reference	MRP (₹)	Std. Pkg. (Nos)
(14*51)	2, 4, 6, 8 & 10	CHFE* 	200	20
(14*51)	16, 20 & 25	CHFE* 	200	
(14*51)	32 & 40	CHFE* 	210	
(14*51)	50	CHFE* 	390	
(14*51)	63	CHFE* 	410	
(10*38)	2, 4, 6, 8, 10 & 16	CGF*	90	20
(10*38)	20 & 25	CGF*	100	
(10*38)	32	CGF*	100	



HRC Fuse Holder for Bolted Type Fuse Link							[HSN Code: 8536]
IS/IEC Size	In A	Reference	MRP (₹)	Std. Pkg. (Nos)	Reference	MRP (₹)	Std. Pkg. (Nos)
F1	20	CNS20H	240	10	-	-	-
F1	32	CNS32H	270	10	-	-	-
A2	32	CSM32H	480	5	-	-	-
A3	63	CSM63H	570	5	-	-	-
A4	100	-	-	-	CSM100H*	1660	3
A4	100	-	-	-	CSM100B*	1860	3

* H-Both side cable B-Top busbar & bottom cable



Fuse Holder for Cylindrical HRC Fuse Link				[HSN Code: 8536]
IS/IEC Size	In A	Reference	MRP (₹)	Std. Pkg. (Nos)
14 x 51	32	CHO32R	260	10
14 x 51	63	CHC63R	320	



Fuse Puller (for DIN type Fuse Link 6-630Amp)			[HSN Code: 8536]
Reference	MRP (₹)	Std. Pkg. (Nos)	
CDFH003	470	1	



LIGHTING TRUNKING

LB Series



Features:

- LB Lighting trunking is used in all kinds of applications:
 - Lighting - Sensors
 - Dimmers - Emergency signalling / alarms
 - Power socket circuits
- Low weight & rigid housing
- High temperature resistance, flame retardant insulation
- Standard design of straight length with Plug in Point & accessories
- Common Plug in Box with detachable phase jaws & Universal bracket
- Quick & easy installation and mounting of luminaires



Lighting Trunking - LB Series

- Conforms -IEC 61439 (1&6)
- Operational voltage -500V
- Range -25A, 40A
- Plug-in unit -6A-16A
- Busbar Configuration - 2P, 4P, 4P+2P, 4P+4P
- Busbar Material - Copper

[HSN Code: 8538]

Type	Description	Reference	UOM	MRP (₹)
Straight length	Straight length 1 meter with 1 PIP 2 Pole, 25A.	LBC252BG5S1P1	NOS	2040
	Straight length 1 meter with 1 PIP 4 Pole, 25A.	LBC254BG5S1P1	NOS	2750
	Straight length 1 meter with 1+1 PIP 4+2 Pole, 25A.	LBC256BG5S2P1	NOS	4750
	Straight length 1 meter with 1+1 PIP 4+4 Pole, 25A.	LBC258BG5S2P1	NOS	5400
	Straight length 1 meter with 1 PIP 2 Pole, 40A.	LBC402BG5S1P1	NOS	2420
	Straight length 1 meter with 1 PIP 4 Pole, 40A.	LBC404BG5S1P1	NOS	3510
	Straight length 1 meter with 1+1 PIP 4+2 Pole, 40A.	LBC406BG5S2P1	NOS	5920
	Straight length 1 meter with 1+1 PIP 4+4 Pole, 40A.	LBC408BG5S2P1	NOS	7010
	Straight length 3 meter with 3 PIP 2 Pole, 25A.	LBC252BG5S1P3	NOS	5310
	Straight length 3 meter with 3 PIP 4 Pole, 25A.	LBC254BG5S1P3	NOS	7200
	Straight length 3 meter with 3+3 PIP 4+2 Pole, 25A.	LBC256BG5S2P3	NOS	12500
	Straight length 3 meter with 3+3 PIP 4+4 Pole, 25A.	LBC258BG5S2P3	NOS	14410
	Straight length 3 meter with 3 PIP 2 Pole, 40A.	LBC402BG5S1P3	NOS	6640
	Straight length 3 meter with 3 PIP 4 Pole, 40A.	LBC404BG5S1P3	NOS	9580
Straight length 3 meter with 3+3 PIP 4+2 Pole, 40A.	LBC406BG5S2P3	NOS	16150	
Straight length 3 meter with 3+3 PIP 4+4 Pole, 40A.	LBC408BG5S2P3	NOS	19130	
Flexible Elbow	Flexible Elbow 1 meter, 2/4 Pole, 25/40A	LBC404BG5FXE1	NOS	9740
	Flexible Elbow 1 meter, 4+2/4+4 Pole, 25/40A	LBC408BG5FXE1	NOS	13400
	Flexible Elbow 3 meter, 2/4 Pole, 25/40A	LBC404BG5FXE3	NOS	14700
	Flexible Elbow 3 meter, 4+2/4+4 Pole, 25/40A	LBC408BG5FXE3	NOS	23300
End Feed Unit	End Feed Unit LHS (Direct), 2/4 Pole, 25/40A.	LBC404BG5EFDL	NOS	4460
	End Feed Unit LHS (Direct), 4+2/4+4 Pole, 25/40A.	LBC408BG5EFDL	NOS	5820
	End Feed Unit LHS (with MCB Provision), 2/4 Pole, 25/40A.	LBC404BG5EFSL	NOS	5900
	End Feed Unit LHS (with MCB Provision), 4+2/4+4 Pole, 25/40A.	LBC408BG5EFSL	NOS	7260
Center Feed unit	Center Feed Unit (Direct), 2/4 Pole, 25/40A.	LBC404BG5CFDS	NOS	10920
	Center Feed Unit (Direct), 4+2/4+4 Pole, 25/40A.	LBC408BG5CFDS	NOS	14580
	Center Feed Unit (with MCB Provision), 2/4 Pole, 25/40A.	LBC404BG5CFSS	NOS	11360
	Center Feed Unit (with MCB Provision), 4+2/4+4 Pole, 25/40A.	LBC408BG5CFSS	NOS	15020
End Cover	End Cover 2/4 Pole, RHS.	LBEC1R	NOS	240
	End Cover 2/4 Pole, LHS.	LBEC1L	NOS	280
	End Cover 4+2/4+4 Pole, RHS.	LBEC2R	NOS	300
	End Cover 4+2/4+4 Pole, LHS.	LBEC2L	NOS	320
Universal Bracket	Universal Bracket 2/4 Pole.	LBHB1U	NOS	360
	Universal Bracket 4+2/4+4 Pole .	LBHB2U	NOS	400
Plug in Box	Plug in Box (Direct), 2 Pole, 16A	LB12BP5D16	NOS	720
	Plug in Box (Direct), 4 Pole, 16A	LB14BP5D16	NOS	860
	Plug in Box (with fuse), 2 Pole, 6A	LB12BP5F06	NOS	900
	Plug in Box (with fuse), 4 Pole, 6A	LB14BP5F06	NOS	1220
	Plug in Box (with fuse), 2 Pole, 16A	LB12BP5F16	NOS	900
	Plug in Box (with fuse), 4 Pole, 16A	LB14BP5F16	NOS	1220

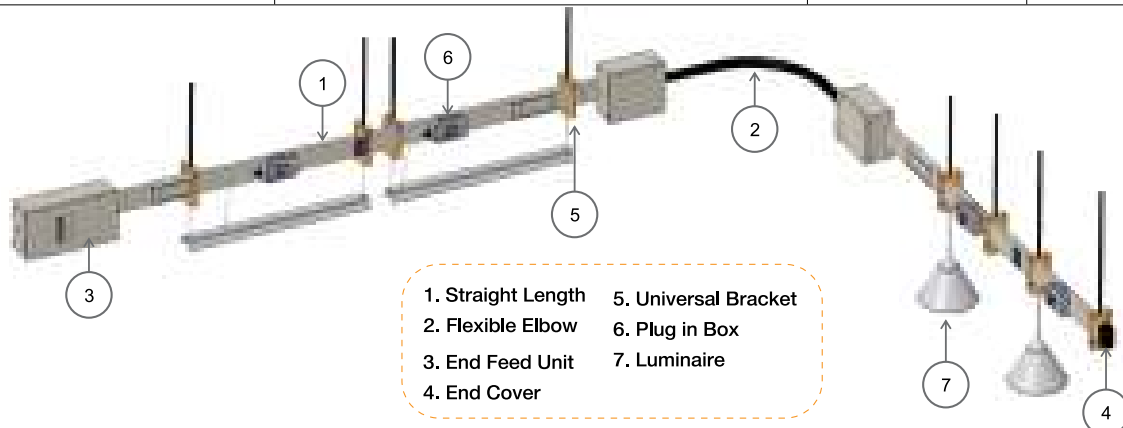



Power **Control** Components



- MPCBs
- Power Contactors
- Mini Contactors
- Overload Relays
- Industrial Plugs & Sockets
- Control & Signalling Devices
- Motor Starters

Motor Protection Circuit Breaker **exceed**

TOGGLE TYPE / ROTARY TYPE



- Conforms to IEC 60947-2
- Overload and Short circuit protection - Toggle and Rotary Type
- Short circuit protection - Rotary Type
- Breaking Capacity upto 100kA
- Finger Safe Terminals
- 35mm DIN Rail mounting

exceed

Motor Protection Circuit Breaker

- Conforms to IEC 60947-2
- Overload and Short circuit protection - Toggle and Rotary Type
- Short circuit protection - Rotary Type
- Breaking Capacity upto 100kA
- Finger Safe Terminals
- 35mm DIN rating mounting



exceed Motor Protection Circuit Breaker - Toggle Type

[HSN Code: 8536]



Frame	Power Rating 3-Ph motors AC3-Duty 415V, 50/60 Hz	Adjustable Range (Amp)	Breaking Capacity(kA) 415V, 50HZ	Reference	MRP (₹)	MOQ
	KW					
32AF	-	0.1-0.16	100	TCMS-32SE-0.16	4320	1
	-	0.16-0.25	100	TCMS-32SE-0.25	4320	
	-	0.25-0.40	100	TCMS-32SE-0.4	4320	
	-	0.40-0.63	100	TCMS-32SE-0.63	4560	
	-	0.63-1	100	TCMS-32SE-1	4560	
	-	1-1.6	100	TCMS-32SE-1.6	4560	
	0.75	1.6-2.5	100	TCMS-32SE-2.5	4560	
	1.5	2.5-4	100	TCMS-32SE-4	4800	
	2.2	4-6.3	100	TCMS-32SE-6.3	4830	
	4	6-10	100	TCMS-32SE-10	4970	
	5.5	9-14	100	TCMS-32SE-14	5670	
	9	13-18	100	TCMS-32SE-18	6560	
	11	17-23	50	TCMS-32SE-23	6560	
	11	20-25	50	TCMS-32SE-25	6950	
	15	24-32	50	TCMS-32SE-32	12820	

ACCESSORIES

[HSN Code: 8538]

Description	Configuration	Model	MRP (₹)	MOQ
Front mounted (1Pc) Aux Contact	1NO+1NC	TFXE11	910	1
Front mounted (1Pc) Aux Contact	2NO	TFXE20	910	
Left Side Mounted (2Pc) Aux Contact	1NO+1NC	TLXE11	1100	
Left Side Mounted (2Pc) Aux Contact	2NO	TLXE20	1100	
Side mounted (1pc) Short circuit signal contact	NO	TLAME11	1800	
Fault signal contact + Aux Contact, Left Side mounted (1Pc.)	2NO	TLAXE1010	1200	
	1NO+1NC	TLAXE1001		
	1NC + 1NO	TLAXE0110		
	2NC	TLAXE0101		
Under Voltage (1 pc) Right side Mounted	110-127V50HZ	TRUE110-127V50HZ	2340	
	220-240V50HZ	TRUE220-240V50HZ		
	380-415V50HZ	TRUE380-415V50HZ		
Shunt Trip (1pc) Right side Mounted	110-127V50HZ	TRSE110-127V50HZ	2340	
	220-240V50HZ	TRSE220-240V50HZ		
	380-415V50HZ	TRSE380-415V50HZ		

exceed

Motor Protection Circuit Breaker



exceed Motor Protection Circuit Breaker - Rotary Type

[HSN Code: 8536]



Frame	Power Rating 3Ph Motors AC3-duty, 415V,50Hz	Rated Operational Current Ie(A)	Breaking Capacity (kA) 415V, 50Hz	Reference	MRP (₹)	Adjustable range (Amp)	Reference	MRP (₹)
				With Short Circuit Protection			With Overload & Short Circuit Protection	
32AF	0.02	0.16	100kA	TCMS-32HIR-0.16	4550	0.1-0.16	TCMS-32HR-0.16	4650
	0.06	0.25		TCMS-32HIR-0.25	4550	0.16-0.25	TCMS-32HR-0.25	4650
	0.09	0.4		TCMS-32HIR-0.4	4550	0.25-0.4	TCMS-32HR-0.4	4650
	0.12	0.63		TCMS-32HIR-0.63	4550	0.4-0.63	TCMS-32HR-0.63	4650
	0.25	1		TCMS-32HIR-1	4550	0.63-1	TCMS-32HR-1	4650
	0.55	1.6		TCMS-32HIR-1.6	5240	1-1.6	TCMS-32HR-1.6	5340
	0.75	2.5		TCMS-32HIR-2.5	5240	1.6-2.5	TCMS-32HR-2.5	5340
	1.5	4		TCMS-32HIR-4	5240	2.5-4	TCMS-32HR-4	5340
	2.2	6.3		TCMS-32HIR-6.3A	5240	4-6.3	TCMS-32HR-6.3	5340
	4	10		TCMS-32HIR-10A	5240	6.3-10	TCMS-32HR-10	5340
	9	16		TCMS-32HIR-16A	5480	10-16	TCMS-32HR-16	6750
	9	20		TCMS-32HIR-20A	5930	16-20	TCMS-32HR-20	6750
	12.5	25		TCMS-32HIR-25A	5930	20-25	TCMS-32HR-25	7160
	15	32		TCMS-32HIR-32A	8180	25-32	TCMS-32HR-32	13100
63AF	7.5	16	50kA	TCMS-63HIR-16	11740	11-16	TCMS-63HR-16	11990
	7.5	20		TCMS-63HIR-20	11740	14-20	TCMS-63HR-20	11990
	11	25		TCMS-63HIR-25	11740	18-25	TCMS-63HR-25	11990
	15	32		TCMS-63HIR-32	20310	22-32	TCMS-63HR-32	20550
	18	40		TCMS-63HIR-40	20310	28-40	TCMS-63HR-40	20550
	18	45		TCMS-63HIR-45	20310	36-45	TCMS-63HR-45	20550
	22	50		TCMS-63HIR-50	21530	40-50	TCMS-63HR-50	21820
	30	63		TCMS-63HIR-63	21530	45-63	TCMS-63HR-63	21820

ACCESSORIES

[HSN Code: 8538]

Description	Configuration	Reference	MRP (₹)
Front Mounted Auxiliary contacts	1NO+1NC	TFXR11	930
Left Side Mounted Auxiliary contacts	2NC	TFXR02	1320
Left Side Mounted Auxiliary contacts	1NO+1NC	TLXR11	1320
Left Side Mounted Auxiliary contacts	2NO	TLXR02	1320
Left Side Mtd Trip ind Aux con (1NC/1NO for OL and 1NO/1NC for SC) for 32AF	1NO+1NC	TLAR3211	2300
Left Side Mtd Trip ind Aux con (1NC/1NO for OL and 1NO/1NC for SC) for 63AF	1NO+1NC	TLAR6311	2400
MPCB Enclosure Frame 32AF	For TCMS-32HIR / 32HR	EPH32HRBG	3470
Extended RotaryHandle -32AF-IP65	For TCMS-32HIR / 32HR	MEH32HR-GB	1670
Extended Rotary Handle -63AF-IP65	For TCMS-63HIR / 63HR	MEH63HR-GB	1760
Shunt Release 32AF / 63AF (Right Side Mounting)	20 ~ 24V 50/60Hz	TRSR20-24V 50/60Hz	2300
	40 ~ 48V 50/60Hz	TRSR40-48V 50/60Hz	
	100 ~ 127V 50/60Hz	TRSR40-100V 127/60Hz	
	200 ~ 240V 50/60Hz	TRSR40-200V 240/60Hz	
	365 - 440V 50/60Hz	TRSR40-365V 440/60Hz	
Under Voltage Release 32AF/63AF (Right Side Mounting)	24V 50/60Hz	TRUR 50Hz 60Hz 24V	2300
	24V 50Hz / 28V 60Hz	TRUR 50Hz 24V 60Hz 28V	
	95V 50Hz / 110V 60Hz	TRUR 50Hz 95V 60Hz 110V	
	110V 50Hz / 120V 60Hz	TRUR 50Hz 110V 60Hz 120V	
	110-115V 50Hz / 127V 60Hz	TRUR 50Hz 110-115V 60Hz 127V	
	180V 50Hz / 208V 60Hz	TRUR 50Hz 180V 60Hz 208V	
	190V 50Hz / 220V 60 Hz	TRUR 50Hz 190V 60Hz 220V	
	208V 50 Hz / 240V 60 Hz	TRUR 50Hz 208V 60Hz 240V	
	230-240V 50Hz / 277V 60Hz	TRUR 50Hz 230-240V 60Hz 277V	
	325V 50Hz / 380V 60Hz	TRUR 50Hz 325V 60Hz 380V	
	380V 50Hz / 440V 60Hz	TRUR 50Hz 380V 60Hz 440V	
400-415V 50Hz / 480V 60Hz	TRUR 50Hz 400-415V 60Hz 480V		
500V 50Hz / 600V 60Hz	TRUR 50Hz 500V 60Hz 600V		

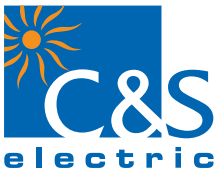

The efficient solution for High Switching in Motor Circuits

robustTa

Contactors 9A~800A



- Safety First
- Compact Modular Design
- Auxiliary Contact In-built
- Low Power Consumption Coils
- Installation Made Easy
- Protective Security Cover





robusta2 Contactor

Global Certification



RoHS Compliant

Conforming IEC60947-1, IEC60947-4-1 & IEC60947-5-1

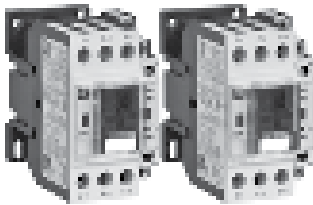

Contactor [HSN Code: 8536]

AC1 Duty (A)	AC3 415V Long life			Auxiliary Contacts	Reference	MRP (₹)	MOQ
	kW	HP	A				
25	2.2	3	7	1 NO+1NC	TC1D0711	1900	1
25	4	5.5	9	1 NO+1NC	TC1D0911	2090	
25	5.5	7.5	12	1 NO+1NC	TC1D1211	2230	
32	9	12	18	1 NO+1NC	TC1D1811	2670	
40	11	15	25	1 NO+1NC	TC1D2511	3390	
50	15	20	32	1 NO+1NC	TC1D3211	7190	
50	18.5	25	38	1 NO+1NC	TC1D3811	9970	

Spare Top Housing for 3P Contactors [HSN Code: 8538]

For Contactor	Reference	MRP (₹)	MOQ
TC1-D0711	TA5-D0711	1440	1
TC1-D0911	TA5-D0911	1440	
TC1-D1211	TA5-D1211	1440	
TC1-D1811	TA5-D1811	1660	
TC1-D2511	TA5-D2511	2140	
TC1-D3211	TA5-D3211	4070	
TC1-D3811	TA5-D3811	6010	

Coil Surge Suppressor [HSN Code: 8538]

Description	Voltage Ratings	Reference	MRP (₹)	MOQ
Varistor (AC/DC) Clip on mounting	12-55V 50/60Hz	TAD4VE	890	10
	56-136V 50/60Hz	TAD4VF	890	
	137-277V 50/60Hz	TAD4VU	890	
	278-575V 50/60Hz	TAD4VN	890	

Spare AC Coils for Contactor [HSN Code: 8538]

Use for Contactor	Reference	MRP (₹)	MOQ
TC1D07	TX1-D3	900	1
TC1D09		900	
TC1D12		900	
TC1D18		900	
TC1D25		900	
TC1D32		900	
TC1D38		900	

Mechanical Interlocks-Horizontal Mounted

Use of Contactor	Reference	MRP (₹)	MOQ
TC1D07-TC1D38	LA9-D09978	800	10

robusta2 Contactor Coils

Contactor TC1-D/TX1D3	24V	48V	110V	220V	240V	415V
50 Hz	B5	E5	F5	M5	U5	N5

Thermal Overload Relay [HSN Code: 8536]

Relay setting range (A)	Standard power ratings of 3-Phase Motors 50/60Hz, AC3 Category		Reference	Suitable for Contactor Rating (Amps)	MRP (₹)	Independent Mounting Kit
	HP	kW				
23-32	20	15	TR2DM32353	32	3910	TA7D3264 MRP ₹540
30-38	30	22	TR2DM38355	38		

NOTE: robusta 2 Thermal Overload Relay reference TR2DM32353 -TR2DM38355 can be mounted directly on robusta2 Contactor without any additional fixing attachment.

How to order:

1. Select applicable Coil Voltage required for Contactor.
2. Complete the code by replacing the ■ from above.
3. For common accessories please refer Page No. 67 & 68.
4. MOQ- Minimum Order Quantity

Exceed M-range Contactor

Conforming IEC60947-1, IEC60947-4-1 & IEC60947-5-1

- Compact size - Single frame upto 16A
- Application flexibility - AC & DC coil
- Front mounted auxiliary contacts
- Compatible with directly mounted Mini OLR
- IP20 guarded terminals



Control Relays - 16 Amps

[HSN Code: 8536]



Rated Current (Ith)	Contact Configuration	With AC Coil			With DC Coil		
		Reference	MRP (₹)	MOQ	Reference	MRP (₹)	MOQ
16	2 NO+2NC	TCA2ME22	1890	10	TCA3ME22	2530	10
	3 NO+1NC	TCA2ME31			TCA3ME31		
	1NO + 3NC	TCA2ME13			TCA3ME13		
	4NO	TCA2ME40			TCA3ME40		
	4NC	TCA2ME04			TCA3ME04		

Power Contactors - 3 Pole

[HSN Code: 8536]



AC1 Duty A	AC3 415V Long Life			Auxiliary Contacts	With AC Coil			Auxiliary Contacts	With DC Coil		
	kW	HP	A		Reference	MRP (₹)	MOQ		Reference	MRP (₹)	MOQ
18	2.2	3	7	1NO -	TC1ME0710	1590	10	1NO -	TP1ME0710	2380	10
				- 1NC	TC1ME0701			- 1NC	TP1ME0701		
20	4	5.5	9	1NO -	TC1ME0910	1730	10	1NO -	TP1ME0910	2480	10
				- 1NC	TC1ME0901			- 1NC	TP1ME0901		
22	5.5	7.5	12	1NO -	TC1ME1210	1840	10	1NO -	TP1ME1210	2720	10
				- 1NC	TC1ME1201			- 1NC	TP1ME1201		
22	7.5	10	16	1NO -	TC1ME1610	2180	10	1NO -	TP1ME1610	3000	10
				- 1NC	TC1ME1601			- 1NC	TP1ME1601		

■ Please specify Coil Voltage.

Coil Voltage Codes for Mini Contactors & Control Relays

Contactor	Voltage				
	24	48	110	230	415
AC	B	E	F	P	N
DC	BD	ED	-	-	-

Overload Relays for M-Range Contactors - Direct Mounting

[HSN Code: 8536]

Relay Range (Amps)	Reference	MRP (₹)	MOQ
0.28 ~ 0.4A	TR2ME0.4A	2200	1
0.4 ~ 0.63A	TR2ME0.63A		
0.56 ~ 0.8A	TR2ME0.8A		
0.8 ~ 1.2A	TR2ME1.2A		
1.2 ~ 1.8A	TR2ME1.8A		
1.8 ~ 2.8A	TR2ME2.8A		
2.8 ~ 4A	TR2ME4A		
4 ~ 6.3A	TR2ME6.3A		
5.6 ~ 8A	TR2ME8A		
7 ~ 10A	TR2ME10A		
8 ~ 12.5A	TR2ME12.5A	2390	1
10 ~ 15A	TR2ME15A		
11 ~ 17A	TR2ME17A		



Exceed M-range Contactor

Conforming IEC60947-1, IEC60947-4-1 & IEC60947-5-1

ACCESSORIES

[HSN Code: 8538]

Add-On-Block

Contact Configuration		Reference	MRP (₹)	MOQ
Front Mounted	2 NO	TA1ME20	550	10
	1 NO+1 NC	TA1ME11		
	2 NC	TA1ME02		
	4 NO	TA1ME40	880	
	3 NO+1 NC	TA1ME31		
	2 NO+2 NC	TA1ME22		
	1 NO+3 NC	TA1ME13		
	4 NC	TA1ME04		

Mechanical Interlocks - Front Mounted

[HSN Code: 8538]

Use For Contactor		Reference	MRP (₹)	MOQ
AC	DC			
TC1ME07	TP1ME07	TA978MIME	730	1
TC1ME09	TP1ME09			
TC1ME12	TP1ME12			
TC1ME16	TP1ME16			

Coil Suppressor

[HSN Code: 8538]

Description	Voltage	Reference	MRP (₹)	MOQ
Varistor	12-48V AC/12-60V DC	TA980MESVE	780	10
	50-127V AC/60-180V DC	TA980MESVG		
	130-275V AC/ 80-300V DC	TA980MESVU		
	277-380V AC/300-510V DC	TA980MESVQ		
	400-510V AC	TA980MESVS		

Exceed Contactor

Conforming IEC60947-1, IEC60947-4-1 & IEC60947-5-1

Exceed 3 Pole Power Contactor rating 6A~95A

[HSN Code: 8536]



Size	AC1 Duty A	AC3 415V Long Life			Auxiliary Contacts	With AC Coil		Auxiliary Contacts	With DC Coil		MOQ
		KW	HP	A		Reference	MRP (₹)		Reference	MRP (₹)	
Frame-1	25	2.2	3	6	1NO	TC1D0610E	1410	-	-	-	1
					1NC	TC1D0601E	1410	-	-	-	
		4	5.5	9	1NO	TC1D0910E	1600	1NO	TP1D0910E	2440	
					1NC	TC1D0901E	1600	1NC	TP1D0901E	2440	
		5.5	7.5	12	1NO	TC1D1210E	1740	1NO	TP1D1210E	2650	
					1NC	TC1D1201E	1740	1NC	TP1D1201E	2650	
32	9	12.5	18	1NO	TC1D1810E	2020	1NO	TP1D1810E	2980		
				1NC	TC1D1801E	2020	1NC	TP1D1801E	2980		
Frame-2	40	11	15	25	1NO	TC1D2510E	2790	1NO	TP1D2510E	4330	
					1NC	TC1D2501E	2790	1NC	TP1D2501E	4330	
	50	15	20	32	1NO	TC1D3210E	5930	1NO	TP1D3210E	8840	
					1NC	TC1D3201E	5930	1NC	TP1D3201E	8840	
Frame-3	60	22	30	40	1NO+1NC	TC1D4011E	8370	1NO+1NC	TP1D4011E	13010	
					1NO+1NC	TC1D5011E	10070	1NO+1NC	TP1D5011E	13670	
	80	25	35	50	1NO+1NC	TC1D6511E	14370	1NO+1NC	TP1D6511E	19470	
					1NO+1NC	TC1D8011E	18280	1NO+1NC	TP1D8011E	24770	
	125	45	60	80	1NO+1NC	TC1D9511E	21790	1NO+1NC	TP1D9511E	29560	
					1NO+1NC	TC1D9511E	21790	1NO+1NC	TP1D9511E	29560	

Exceed 4 Pole Power Contactor rating 12A~95A

[HSN Code: 8536]

AC1 Duty A	Main Pole Configuration		Reference	MRP (₹)	MOQ
25	4NO	--	TC1D12004E	1950	5
	2NO	2NC	TC1D12008E	2470	
32	4NO	--	TC1D18004E	2260	
40	4NO	--	TC1D25004E	3300	
	2NO	2NC	TC1D25008E	4870	
60	4NO	--	TC1D40004E	8890	
	2NO	2NC	TC1D40008E	14030	
80	4NO	--	TC1D50004E	11240	
	2NO	2NC	TC1D50008E	15140	
	4NO	--	TC1D65004E	14450	
	2NO	2NC	TC1D65008E	16650	
125	4NO	--	TC1D80004E	18520	
	2NO	2NC	TC1D80008E	22710	
	4NO	--	TC1D95004E	23080	
	2NO	2NC	TC1D95008E	24780	

Wide band Coil available in 50 Hz only ■ Non-Standard coil Extra MRP @ ₹200 per contactor
 Note: Stock for accessories are subject to availability * Available from CR-38A Contactor only.

AC Coil Voltage Codes for Contactors 9A-95A & Control Relays

Contactor	Voltage						
TC1-D	24	48	110	220	235	240	415
50Hz	B5	E5	F5	M5	C5W*	U5	N5
50/60Hz	B7	E7	F7	M7	-	U7	N7

DC Coil Voltage Codes for Contactors 9A-95A & Control Relays

Contactor	Voltage				
TP1-D	24	48	72	110	220
Normal Coil	BD	ED	SD	FD	MD
Wide band Coil#	BW	EW	-	FW	-

- NOTE:**
1. Add Suffix ■ Coil voltage to complete product code
 2. 235 V (C5W) Coil available only upto 38 Amps (AC3) Contactors.
 3. 22A, 38A & 45A current ratings also available on request. (MOQ - 50 Nos.)
 4. For add-on accessories and spare coil refer Page No. 67 & 68.





















Exceed Contactor

Conforming IEC60947-1, IEC60947-4-1 & IEC60947-5-1



















Exceed Contactor 3 Pole: Rating 115 A- 630A

[HSN Code: 8536]

AC1 Duty A	AC3 415V Long Life			With AC Coil		With DC Coil		MOQ
	kW	HP	A	Reference	MRP (₹)	Reference	MRP (₹)	
200	59	80	115	LC1FDP115AE 	26670	LC1FDP115AE 	32000	5
250	80	108	150	LC1FDP150AE 	37860	LC1FDP150AE 	45440	
275	100	136	185	LC1FDP185AE 	43910	LC1FDP185AE 	52700	
315	110	148	225	LC1FDP225AE 	49640	LC1FDP225AE 	59580	
350	140	190	265	LC1FDP265AE 	59090	LC1FDP265AE 	70910	
400	180	240	330	LC1FDP330AE 	71890	LC1FDP330AE 	86270	
500	220	300	400	LC1FDP400AE 	84700	LC1FDP400AE 	101650	
700	280	380	500	LC1FDP500AE 	119900	LC1FDP500AE 	143870	
1000	375	500	630	LC1FDP630AE 	175360	LC1FDP630AE 	210440	

Exceed Contactors 4 Pole: Rating AC1 200A ~ 1000A

[HSN Code: 8536]

AC1 Duty A	Main Pole Configuration	With AC Coil		With DC Coil		MOQ
		Reference	MRP (₹)	Reference	MRP (₹)	
200	4 NO	LC1FDP1154AE 	32820	LC1FDP1154AE 	POR	5
250	4 NO	LC1FDP1504AE 	42080	LC1FDP1504AE 		
275	4 NO	LC1FDP1854AE 	62110	LC1FDP1854AE 		
315	4 NO	LC1FDP2254AE 	62890	LC1FDP2254AE 		
350	4 NO	LC1FDP2654AE 	68470	LC1FDP2654AE 		
400	4 NO	LC1FDP3304AE 	81140	LC1FDP3304AE 		
500	4 NO	LC1FDP4004AE 	104640	LC1FDP4004AE 		
700	4 NO	LC1FDP5004AE 	125560	LC1FDP5004AE 		
1000	4 NO	LC1FDP6304AE 	248320	LC1FDP6304AE 		

AC Coil Voltage Codes for Contactors 115A-780A

Contactor	Voltage			
	110	220	240	415
LC1FDP115-225 50Hz	F5	M5	U5	N5
LC1FDP265-780 50/60Hz	F7	M7	U7	N7

DC Coil Voltage Codes for Contactors 115A-780A

Contactor	Voltage			
	24#	48	110	220
LC1FDP	BD	ED	FD	MD

Not available for LCFDP630



robusta Power Contactors

Global Certification



Conforming IEC60947-1, IEC60947-4-1 & IEC60947-5-1



Control Relays - 10 Amps [HSN Code: 8536]

Rated Current(Ie) AC15 at 240V (Amps)	Contact Configuration	With AC Coil		With DC Coil		
		Reference	MRP (₹)	Reference	MRP (₹)	MOQ
10	2NO + 2NC	TCA2-DN22	1950	TCA3-DN22	3030	10
	3NO + 1NC	TCA2-DN31		TCA3-DN31		
	4NO	TCA2-DN40		TCA3-DN40		

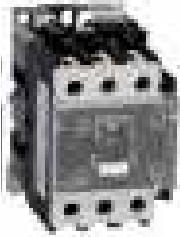

Power Contactors 3 Pole : Rating 9A ~ 95A [HSN Code: 8536]

Size	AC1 Duty A	AC3 415V Long Life			Auxiliary Contacts		With AC Coil		Auxiliary Contacts		With DC Coil		MOQ
		kW	HP	A			Reference	MRP (₹)			Reference	MRP (₹)	
Frame 1	25	4	5.5	9	1NO	-	TC1-D0910	1810	1NO	-	TP1-D0910	2840	1
					-	1NC	TC1-D0901	1810	-	1NC	TP1-D0901	2840	
	5.5	7.5	12	1NO	-	TC1-D1210	2040	1NO	-	TP1-D1210	3150		
				-	1NC	TC1-D1201	2040	-	1NC	TP1-D1201	3150		
	32	9	12.5	18	1NO	-	TC1-D1810	2480	1NO	-	TP1-D1810	3590	
					-	1NC	TC1-D1801	2480	-	1NC	TP1-D1801	3590	
11	15	22	1NO	-	TC1-D2210	2890	1NO	-	TP1-D2210	5100			
			-	1NC	TC1-D2201	2890	-	1NC	TP1-D2201	5100			
Frame 2	40	11	15	25	1NO	-	TC1-D2510	3170	1NO	-	TP1-D2510	5290	
					-	1NC	TC1-D2501	3170	-	1NC	TP1-D2501	5290	
	15	20	32	1NO	-	TC1-D3210	6510	1NO	-	TP1-D3210	10240		
				-	1NC	TC1-D3201	6510	-	1NC	TP1-D3201	10240		
	18.5	25	38	1NO	-	TC1-D3810	9120	1NO	-	TP1-D3810	11860		
				-	1NC	TC1-D3801	9120	-	1NC	TP1-D3801	11860		
	18.5	25	40	1NO	-	TC1-D4010	9300	-	-	-	-		
				-	1NC	TC1-D4001	9300	-	-	-	-		
	Frame 3	60	22	30	40	1NO	1NC	TC1-D4011	9710	1NO	1NC	TP1-D4011	14300
						1NO	1NC	TC1-D4511	11500	1NO	1NC	TP1-D4511	17040
		25	35	50	1NO	1NC	TC1-D5011	12090	1NO	1NC	TP1-D5011	18070	
					1NO	1NC	TC1-D6511	16100	1NO	1NC	TP1-D6511	19350	
100		37	50	70	1NO	1NC	TC1-D7011	16630	1NO	1NC	TP1-D7011	22500	
125		45	60	80	1NO	1NC	TC1-D8011	20290	1NO	1NC	TP1-D8011	24190	
	1NO				1NC	TC1-D9511	24570	1NO	1NC	TP1-D9511	30930		

AC Coil Voltage Codes for Contactors 9A-95A & Control Relays

Contactor	Voltage						
	24	48	110	220	235	240	415
TCA2-DN/TC1-D							
50Hz	B5	E5	F5	M5	C5W*	U5	N5
50/60Hz	B7	E7	F7	M7	-	U7	N7

DC Coil Voltage Codes for Contactors 9A-95A & Control Relays

Contactor	Voltage				
	24	48	72	110	220
TCA3-DN/TP1-D					
Normal Coil	BD	ED	SD	FD	MD
Wide band Coil#	BW	EW	-	FW	-

Wide band Coil available in 50 Hz only
 Note: Stock for accessories are subject to availability ■ Non-Standard coil Extra MRP @ ₹ 200 per contactor
 *Available from CR-38A Contactor only. BIS (§) is available on selective ratings.



robusta Power Contactors

Global Certification



Conforming IEC60947-1 & IEC60947-4-1

Power Contactors 4 Pole : Rating AC1 25A ~ 125A

[HSN Code: 8536]



AC1 Duty A	AC1 Duty A	Main Pole Configuration		With AC Coil		With DC Coil		MOQ
				Reference	MRP (₹)	Reference	MRP (₹)	
Frame 1	25	4NO	--	TC1-D12004	2270	TP1-D12004	4450	1
		2NO	2NC	TC1-D12008	2780	TP1-D12008	5590	
	32	4NO	--	TC1-D18004	2610	-	-	
Frame 2	40	4NO	--	TC1-D25004	3850	TP1-D25004	8580	
		2NO	2NC	TC1-D25008	5410	TP1-D25008	10740	
Frame 3	60	4NO	--	TC1-D40004	10240	TP1-D40004	15330	
		2NO	2NC	TC1-D40008	15150	TP1-D40008	22840	
	80	4NO	--	TC1-D50004	12790	-	-	
		2NO	2NC	TC1-D50008	17550	-	-	
		4NO	--	TC1-D65004	16590	TP1-D65004	24490	
	100	2NO	2NC	TC1-D65008	19320	TP1-D65008	29670	
		4NO	--	TC1-D70004	17190	TP1-D70004	28200	
		125	4NO	--	TC1-D80004	21460	TP1-D80004	30750
			2NO	2NC	TC1-D80008	26120	TP1-D80008	34390
	125	4NO	--	TC1-D95004	25950	TP1-D95004	32770	
2NO		2NC	TC1-D95008	28480	TP1-D95008	35550		

Power Contactors 4 Pole 4NC : Rating 9A ~ 25A

[HSN Code: 8536]

Size	AC1 Duty A	AC3 415 V Long Life			With AC Coil		MRP (₹)	MOQ
		KW	HP	A	Reference			
Frame 1	25	4	5.5	9	TC1-D09006	2450	10	
		5.5	7.5	12	TC1-D12006	4540		
Frame 2	40	11	15	25	TC1-D25006	5050		

AC Coil Voltage Codes for Contactors 9A-95A & Control Relays

Contactor	Voltage						
	24	48	110	220	235	240	415
50Hz	B5	E5	F5	M5	C5W*	U5	N5
50/60Hz	B7	E7	F7	M7	-	U7	N7

DC Coil Voltage Codes for Contactors 9A-95A & Control Relays

Contactor	Voltage				
	24	48	72	110	220
Normal Coil	BD	ED	SD	FD	MD
Wide band Coil#	BW	EW	-	FW	-

- NOTE:**
1. Add Suffix ■ Coil voltage to complete product code
 2. 235 V (C5W) Coil available only upto 38 Amps (AC3) Contactors.
 3. 22A, 38A & 45A current ratings also available on request. (MOQ - 50 Nos.)
 4. For add-on accessories and spare coil refer Page No. 67 and 68.

Wide band Coil available in 50 Hz only

Note: Stock for accessories are subject to availability

■ Non-Standard coil Extra MRP @ ₹ 200 per contactor

* Available from CR-38A Contactor only.

robusta Power Contactors

Conforming IEC60947-1 & IEC60947-4-1



Power Contactors 3 Pole : 115~160A AC3 [HSN Code: 8536]

AC1 Duty A	AC3 415 V Long Life			Auxiliary contacts		With AC Coil		MOQ
	kW	HP	A			Reference	MRP (₹)	
200A	55	73	115	1NO	1NC	TC1-D115116■*	28960	1
	55	73	115	1NO	1NC	TC1-D11511■*	29220	
	55	73	120	1NO	1NC	TC1-D120116■*	29820	
	55	73	120	1NO	1NC	TC1-D12011■*	30220	
	75	101	150	1NO	1NC	TC1-D150116■*	38940	
	75	101	150	1NO	1NC	TC1-D15011■*	39550	
	75	101	160	1NO	1NC	TC1-D160116■*	40380	
	75	101	160	1NO	1NC	TC1-D16011■*	40760	

Power Contactors 4 Pole: Rating AC1 200A [HSN Code: 8536]

AC1 Duty A	Main Pole Configuration		With AC Coil		MOQ
			Reference	MRP (₹)	
200A	4NO	--	TC1-D115004■*	31660	1
	4NO	--	TC1-D1150046■*	31240	
	4NO	--	TC1-D150004■*	41160	
	4NO	--	TC1-D1500046■*	40970	

* Busbar connection * Cable connection

AC Coil Voltage

Contactor	Voltage			
		110	24	220
50Hz	F5	B5	M5	N5



robusta Power Contactors

Global Certification



Conforming IEC60947-1 & IEC60947-4-1

Power Contactors with Dust Cover 3 Pole

[HSN Code: 8536]

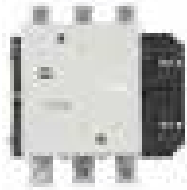
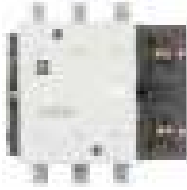

AC1 Duty A	AC3 Long Life			With AC Coil		With DC Coil		MOQ
	kW	HP	A	Reference	MRP (₹)	Reference	MRP (₹)	
200	59	80	115	LC1FDP115A	31030	LC1FDP115A	36490	1
250	80	108	150	LC1FDP150A	43060	LC1FDP150A	53010	
275	100	136	185	LC1FDP185A	50510	LC1FDP185A	64930	
275	105	140	200	LC1FDP200A	55220	LC1FDP200A	65440	
315	110	148	225	LC1FDP225A	57320	LC1FDP225A	71390	
350	140	190	265	LC1FDP265A	70340	LC1FDP265A	76590	
350	150	200	300	LC1FDP300A	76650	LC1FDP300A	90290	
400	180	240	330	LC1FDP330A	84380	LC1FDP330A	101260	
500	220	300	400	LC1FDP400A	98090	LC1FDP400A	121320	
600	240	320	460	LC1FDP460A	128690	-	-	
700	280	380	500	LC1FDP500A	135440	LC1FDP500A	146630	
800	355	430	580	LC1FDP580A	138480	-	-	
1000	375	500	630	LC1FDP630A	200590	LC1FDP630A	225070	
1600	425	580	780	LC1FDP780A	POR	LC1FDP780A	POR	
1000	450	610	800	LC1FDP800A	374920	LC1FDP800A*	385050	

- Power Contactors with dust cover 2 Pole variants available on requests
- Power Contactors with dust cover rating 115-800A are supplied factory assembled complete with No-Volt Coil and auxiliary contact block 2NO+2NC.
- *For DC supply, Bypass rectifier and connect DC supply directly to coil terminals A1-A2

Hoisting Power Contactors with dust cover 3 Pole: Rating 115A ~ 630A

[HSN Code: 8536]

AC1 Duty A	AC3 415 V Long Life			With AC Coil		MOQ
	kW	HP	A	Reference	MRP (₹)	
200	59	80	115	LC1FDP115HCA	POR	1
250	80	110	150	LC1FDP150HCA		
275	100	135	185	LC1FDP185HCA		
315	110	150	225	LC1FDP225HCA		
350	140	190	265	LC1FDP265HCA		
355	150	200	300	LC1FDP300HCA		
400	180	220	330	LC1FDP330HCA		
500	220	300	400	LC1FDP400HCA		
700	280	380	500	LC1FDP500HCA		
1000	375	500	630	LC1FDP630HCA		

Power Contactors with dust cover 4 Pole : Rating AC1 200A ~ 1600A

[HSN Code: 8536]

AC1 Duty A	Main Pole Configuration	With AC Coil		With DC Coil		MOQ
		Reference	MRP (₹)	Reference	MRP (₹)	
200	4 NO	LC1FDP1154	37370	LC1FDP1154	50150	1
250	4 NO	LC1FDP1504n	46980	LC1FDP1504	67130	
275	4 NO	LC1FDP1854	70710	LC1FDP1854	89770	
315	4 NO	LC1FDP2254	72300	LC1FDP2254	88510	
350	4 NO	LC1FDP2654	78300	LC1FDP2654	98190	
400	4 NO	LC1FDP3304	90990	LC1FDP3304	118300	
500	4 NO	LC1FDP4004	118530	LC1FDP4004	141740	
700	4 NO	LC1FDPM5004	143590	LC1FDPM5004	170840	
1000	4 NO	LC1FDP6304	277050	LC1FDP6304	286100	
1600	4 NO	LC1FDP7804	POR	LC1FDP7804	POR	

AC Coil Voltage Codes for Contactors 115A-780A

DC Coil Voltage Codes for Contactors 115A-780A

Contactor	Voltage			
	110	220	240	415
LC1FDP115-225 50Hz	F5	M5	U5	N5
LC1FDP265-780 50/60Hz	F7	M7	U7	N7

Contactor	Voltage			
	24#	48	110	220
LC1FDP	BD	ED	FD	MD

Not available for LC1FDP630 & LC1FDP780

- ◆ Not Available for LC1FDP780
- Non-Standard coil available on request, Extra MRP@ ₹ 990 each per Contactor rating 115#780A

Minimum Order Qty. for Hoisting Power Contactors will be 10 Nos.
4 Pole Power Contactors with dust cover rating AC1 200-1600A are supplied factory assembled complete with No-Volt Coil and auxiliary contact block 2NO+2NC.

Coil Voltage Codes for Contactor 800A

Contactor	Voltage		
	110/127	220/240	380/400
LC1-FDP - AC	FW*	MW*	QW**
LC1-FDP-DC	FW	MW	QW

*With rectifier DRTE4U **With rectifier DRTE4S

Capacitor Duty Contactors 3 Pole, AC

Global Certification



Conforming IEC60947-1 & IEC60947-4-1

Contactors

[HSN Code: 8536]

Size	kVAR Rating	Auxiliary Contacts	Reference	MRP (₹)	MOQ
Frame 1	7	1NO+1NC	TC1D07K11	3610	1
		2NC	TC1D07K02	3610	
	10	1NO+1NC	TC1D10K11	3920	
		2NC	TC1D10K02	3920	
	12.5	1NO+1NC	TC1D12K11	4220	
		2NC	TC1D12K02	4220	
16.7	1NO+1NC	TC1D16K11	5950		
	2NC	TC1D16K02	5950		
Frame 2	20	1NO+1NC	TC1D20K11	6730	
		2NC	TC1D20K02	6730	
	25	1NO+1NC	TC1D25K11	7490	
		2NC	TC1D25K02	7490	
Frame 3	33.3	1NO+2NC	TC1D33K12	13460	
	40	1NO+2NC	TC1D40K12	20110	
	50	1 NO+2NC	TC1D50K12	20720	
	60	1NO+2NC	TC1D60K12	23730	
	75	1NO+2NC	TC1D75K12	27540	
	80	1NO+2NC	TC1D80K12	29530	
	100	1NO+2NC	TC1D100K12	30270	



AC Coil Voltage robusTa Capacitor Duty Contactors

Contactor	Voltage					
	24	110	220	235	240	415
50Hz	B5	F5	M5	C5W*	U5	N5
50/60Hz	B7	F7	M7	-	U7	N7

* Available upto 25kVAR only.

How to order:

- i) Select applicable Coil Voltage required for Contactor.
- ii) Complete the code by replacing the ■
- iii) To order additional Auxiliary Block, Timers and other accessories, please refer Page No. 67 & 68.



robusta Overload Relay

Global Certification   

Conforming IEC60947-1, IEC60947-4-1 & IEC60947-5-1

Thermal Overload Relays Direct Mounting Trip class 10

[HSN Code: 8536]

Relay Setting Range (Amps)	Standard Power Rating for 3 Ph. Motor at 415V		Reference	Suitable for Contactor Rating (Amps)	MRP (₹)	Independent Mounting Kit	MOQ	
	HP	kW						
Direct Mounting								
0.10 ~ 0.16	*	*	<input checked="" type="checkbox"/> TRD09301	9	2290	TA7-D0964 MRP ₹420 [HSN Code: 8538]	1	
0.16 ~ 0.25	*	*	<input checked="" type="checkbox"/> TR2D09302		2290			
0.25 ~ 0.40	*	*	TR2D09303		2290			
0.40 ~ 0.63	*	*	TR2D09304		2290			
0.63 ~ 1.00	0.5	0.37	TR2D09305		2290			
1.00 ~ 1.60	0.75	0.55	TR2D09306		2290			
1.25 ~ 2.00	1	0.75	TR2D093X6		2290			
1.60 ~ 2.50	1.5	1.1	TR2D09307		2290			
2.50 ~ 4.00	2	1.5	TR2D09308		2290			
4.00 ~ 6.00	3	2.2	TR2D09310		2290			
5.50 ~ 8.00	5	3.7	TR2D09312		2290			
7.00 ~ 10.0	5.5	4	TR2D09314		2290			
9.0 ~ 13.0	7.5	5.5	TR2D12316		12			2290
9.0 ~ 14.0	7.5	5.5	TR2D12316X		12			2290
12.0 ~ 18.0	12	9	TR2D18321		18			2770
14.0 ~ 22.0	12	9	TR2D18321X		18			2770
17.0 ~ 25.0	15	11	TR2D25322	25	2770			
23.0 ~ 32.0	20	15	TR2D32353	32	3960	TA7-D3264 MRP ₹ 540 [HSN Code: 8538]		
28.0 ~ 36.0	25	18	TR2D32355		3960			
23.0 ~ 32.0	20	15	TR2D40353	40	4300	TA7-D4064 MRP ₹1960 [HSN Code: 8538]		
30.0 ~ 40.0	30	22	TR2D40355		4300			
37.0 ~ 50.0	35	25	TR2D65357	50	5540			
48.0 ~ 65.0	40	30	TR2D65359	65	7120			
55.0 ~ 70.0	50	37	TR2D65361		7120			
63.0 ~ 80.0	60	45	TR2D80363	80	7860			
80.0 ~ 93.0	65	49	TR2D95365	95	7920			
Independent Mounting								
65 ~ 105	75	55	LR1F105	-	12750	-	1	
80 ~ 125	80	59	LR1F125		12750			
100 ~ 160	110	80	LR1F160		12750			
125 ~ 200	135	100	LR1F200		12750			
160 ~ 250	175	129	LR1F250		12750			
200 ~ 315	220	160	<input checked="" type="checkbox"/> LR1F315		16350			
250 ~ 400	270	200	<input checked="" type="checkbox"/> LR1F400		16350			
315 ~ 500	350	257	<input checked="" type="checkbox"/> LR1F500		16350			
400 ~ 630	480	355	<input checked="" type="checkbox"/> LR1F630		16350			
500 ~ 800	580	425	<input checked="" type="checkbox"/> LR1F800		46810			
630 ~ 1000	680	500	<input checked="" type="checkbox"/> LR1F1000		46810			

Thermal Overload Relays Protective Shroud for LR1-F105-630 [HSN Code: 8538]

Relay Type	Reference	MRP (₹)	MOQ
LR1-F105	<input checked="" type="checkbox"/> LA9F702	2780	1
LR1-F125		2780	
LR1-F160		2780	
LR1-F200		2780	
LR1-F250	LA9F703	3670	
LR1-F315		3670	
LR1-F400		3670	
LR1-F500		3670	
LR1-F630	LA9F704	3960	
LR1-F800		3960	

Heavy Duty Overload Relays Independent Mounting Trip class 30 [HSN Code: 8536]

Relay Setting Range (Amps)	Reference	MRP (₹)	MOQ
2.5-4.0	TR6F4	17940	1
4.0-6.3	TR6F6.3	17940	
6.3-10	TR6F10	17940	
8.0-12.5	TR6F12.5	17940	
10-16	TR6F16	17940	
16-25	TR6F25	17940	
25-40	<input checked="" type="checkbox"/> TR6F40	17940	
40-63	<input checked="" type="checkbox"/> TR6F63	17940	
63-100	<input checked="" type="checkbox"/> TR6F100	17940	
100-160	<input checked="" type="checkbox"/> TR6F160	17940	
125-200	<input checked="" type="checkbox"/> TR6F200	17940	
160-250	<input checked="" type="checkbox"/> TR6F250	17940	
250-400	<input checked="" type="checkbox"/> TR6F400	17940	

Accessories for robusTa & Exceed Contactors

Add-On Block for Contactor Rating 9A-800A [HSN Code: 8538]



Contact Configuration		Reference	MRP (₹)	MOQ	
Front Mounted	1 NO	TA1-DN10*	290	10	
	1 NC	TA1-DN01*			
	2 NO	TA1-DN20			
	1 NO+1 NC	TA1-DN11	610	20	
		2 NC			TA1-DN02
		4 NO			TA1-DN40
		3 NO+1 NC			TA1-DN31
	900	2 NO+2 NC	TA1-DN22	900	20
		1 NO+3 NC	TA1-DN13		
		4 NC	TA1-DN04		
Side Mounted		1 NO+1 NC	TA8-DN11**		
	2 NO	TA8-DN20**			

* Suitable for robusTa Contactor rating 25-95A only. * 25A-38A, 1 Nos can be fitted & for 40-95A, 2 Nos.

** Suitable for robusTa Contactor rating 9-95A only & can be used for TC1-D115-160A

Mechanical Interlocks - Horizontal Mounted [HSN Code: 8538]

Contact Configuration		Reference	MRP (₹)	MOQ
AC	DC			
TC1-D09	TP1-D09	LA9-D09978	800	10
TC1-D12	TP1-D12			
TC1-D18	TP1-D18			
TC1-D25	TP1-D25			
TC1-D32	TP1-D32			
TC1-D40	TP1-D40	LA9-D50978	1960	10
TC1-D50	TP1-D50			
TC1-D65	TP1-D65			
TC1-D70	TP1-D70	LA9-D80978	2570	10
TC1-D80	TP1-D80			
TC1-D95	TP1-D95			

Coil Surge Suppressor for Contactor 9-95A [HSN Code: 8538]

Description	Voltage Ratings	Reference	MRP (₹)	MOQ
Varistor (AC/DC) Clip-on mounting	24-48VAC/DC	TA9AMOV980E	800	10
	110-240V AC/DC	TA9AMOV980U		
	70-150V AC/DC	TA9AMOV980F		
RC Circuit (AC) Clip-on mounting	24-48V AC	TA9RC980E	800	10
	110-240V AC	TA9RC980U		
	380-440V AC	TA9RC980N		

***Coil Surge Suppressor - Contactor 115-630A**

Description	Reference	MRP (₹)	MOQ
Coil Surge Suppressor for LC1FDP115-630A (3P/4P)	LA9F980(BR)*	3480	5

* Common for Exceed & Robusta Contactors. * Only for 220V AC



Pneumatic Timer Block - Front Mounted [HSN Code: 8538]

Contact Configuration		Reference	MRP (₹)	MOQ
ON delay	1 NO+1 NC	TA2-DT0	3010	10
ON delay	1 NO+1 NC	TA2-DT2		
ON delay	1 NO+1 NC	TA2-DT4		
OFF delay	1 NO+1 NC	TA3-DR0		
OFF delay	1 NO+1 NC	TA3-DR2		
OFF delay	1 NO+1 NC	TA3-DR4		
Star Delta	1 NO+1 NC	TA2-DS2		

Electrical & Mechanical Interlocks-Horizontal Mounted

Use for Contactor		Reference*	MRP (₹)	MOQ
AC	DC			
TC1-D09	TP1-D09	ELA9-D09978	950	10
TC1-D12	TP1-D12			
TC1-D18	TP1-D18			
TC1-D25	TP1-D25			
TC1-D32	TP1-D32			
TC1-D40	TP1-D40	ELA9-D50978	2130	10
TC1-D50	TP1-D50			
TC1-D65	TP1-D65			
TC1-D80	TP1-D80	ELA9-D80978	2770	10
TC1-D95	TP1-D95			

Spare AC Coils Control Relay & Contactor 9A-95A

Use for Contactor AC	Reference	MRP (₹)	MOQ
TCA2-DN	TX1-D2 ■	840	20
TC1-D09			
TC1-D12			
TC1-D18			
TC1-D25	TX1-D4 ■	1020	10
TC1-D32			
TC1-D40			
TC1-D50			
TC1-D63	TX1-D6 ■	2660	10
TC1-D80			
TC1-D95			

■ Please specify Coil Voltage

Spare DC Coils Control Relay & Contactor 9A-95A

Use for Contactor DC	Reference		MRP (₹)	MOQ
	Normal	Wideband		
TCA3 - DN	TX4-D2 ■	TX5-D2 ■	1360	1
TP1 - D09				
TP1 - D12				
TP1 - D18				
TP1 - D25	TX4-D4 ■	TX5-D4 ■	1500	1
TP1 - D32				
TP1 - D40				
TP1 - D50				
TP1 - D65	TX4-D40 ■	TX5-D40 ■	3490	1
TP1 - D80				
TP1 - D95				
TP1 - D80	TX4-D80 ■	TX5-D80 ■	7310	1
TP1 - D95				

Spare AC Coils for Hoisting Power Contactor

Contactor	110V	220V	240V	415V	MRP (₹)
LC1-FDP115HCA	LX9FF110V	LX9FF220V	LX9FF240V	-	5760
LC1-FDP150HCA					
LC1-FDP185HCA	LX9FG110V	LX9FG220V	LX9FG240V	-	8410
LC1-FDP225HCA					
LC1-FDP265HCA	LX9FH1102V	LX9FH2202V	LX9FH2402V	-	9190
LC1-FDP330HCA					
LC1-FDP400HCA	LX9FJ925	LX9FJ931	LX9FJ932	LX9FJ936	18630
LC1-FDP500HCA	LX9FK925	LX9FK931	LX9FK932	LX9FK936	31490
LC1-FDP630HCA	LX9FL924	LX9FL930	LX9FL931	LX9FL936	31840

Spare AC Coils for Contactors Rating 115-800A

Contactor	110V	220V	240V	415V	MRP (₹)
LC1-FDP115A	LX1FF-110V	LX1FF-220V	LX1FF-240V	LX1FF-415V	4350
LC1-FDP150A					
LC1-FDP185A	LX1FG-110V	LX1FG-220V	LX1FG-240V	LX1FG-415V	7850
LC1-FDP200A					
LC1-FDP225A					
LC1-FDP265A	LX1FH-1102V	LX1FH-2202V	LX1FH-2402V	LX1FH-4152V	9190
LC1-FDP300A					
LC1-FDP330A					
LC1-FDP400A	LX1FJ-110V	LX1FJ-220V	LX1FJ-240V	LX1FJ-415V	12210
LC1-FDP500A	LX1FK-110V	LX1FK-220V	LX1FK-240V	LX1FK-415V	29070
LC1-FDP630A	LX1FL-110V	LX1FL-220V	LX1FL-240V	LX1FL-415V	29580
LC1-FDP780A	LX1FX-110V	LX1FX-220V	LX1FX-240V	LX1FX-415V	70700
LC1-FDP800A	LX4F8FWAC	LX4F8MWAC	LX4F8MWAC	LX4F8QWAC*	31030

Front Mount Add on block with IP67

[HSN Code: 8538]

Robusta TA2 contactors

Reference Item	Pole Configuration	MRP (₹)	Reference Item	Pole Configuration	MRP (₹)
TA1DX11	11	1640	TA1DX11 N11	X11 N11	1990
TA1DX20	20	1640	TA1DX11 N20	X11 N20	1990
TA1DX02	02	1640	TA1DX11 N02	X11 N02	2000
TA1DX20 N20	X20 N20	1850	TA1DX02 N11	X02 N11	1990
TA1DX20 N11	X20 N11	1850	TA1DX02 N20	X02 N20	1990
TA1DX20 N02	X20 N02	1860	TA1DX02 N02	X02 N02	2000

NOTE :- "X" DENOTES IP67

"N" DENOTES NORMAL CONTACTS

FOR EXAMPLE:- TA1D(X)02 (N)20

ADD ON BLOCK SERIES IP67 NORMAL CONTACT

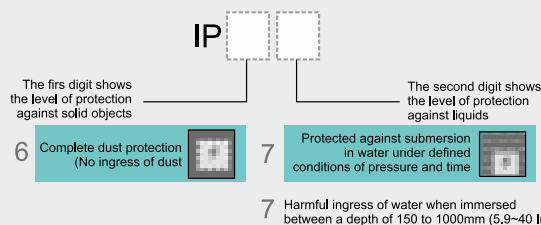

Compatible products

- 9A-800A Robusta & Exceed 3 Pole & 4 Pole Contactors
- 9A-90A D-Range Contactors
- 1250A to 2600A Robusta 3 Pole Contactors



D Range Contactors & Overload Relays Global Certification   
 Conforming IEC60947-1, IEC60947-4-1 & IEC60947-5-1

Control Relays 10 Amps			[HSN Code: 8536]
Contact Configuration	A.C. Reference	MRP (₹)	MOQ
2NO+2NC	CA2DN1229 ■	1920	1
3NO+1NC	CA2DN1319 ■		
4NO	CA2DN140 ■		

■ Please specify Coil Voltage

Power Contactors - 3 Pole, AC [HSN Code: 8536]

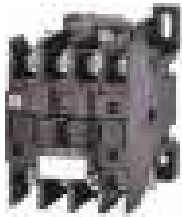

Size	AC1 Duty A	AC3 415V Long Life			Auxiliary Contacts		Reference	MRP (₹)	MOQ
		KW	HP	A					
Frame 1	25	4	5.5	9	1NO	-	LC1D093 ■	1780	1
					-	1NC	LC1D099 ■	1780	
	25	5.5	7.5	12	1NO	-	LC1D123 ■	1990	
					-	1NC	LC1D129 ■	1990	
	32	9	12.5	16	1NO	-	LC1D173 ■	2340	
					-	1NC	LC1D179 ■	2340	
	32	11	15	22	1NO	-	LC1D223 ■	2700	
					-	1NC	LC1D229 ■	2700	
Frame 2	40	11	15	25	1NO	-	LC1D253 ■	3120	
					-	1NC	LC1D259 ■	3120	
	50	15	20	32	1NO	-	LC1D323 ■	6370	
					-	1NC	LC1D329 ■	6370	
Frame 3	60	22	30	40	1NO	1NC	LC1D403 ■	9340	
	80	25	35	50	1NO	1NC	LC1D503 ■	11210	
	80	37	50	63	1NO	1NC	LC1D633 ■	15800	
	125	45	60	80	1NO	1NC	LC1D803 ■	19840	



Thermal Overload Relays Type LR1-Direct Mounting

Relay Setting Range A	Std. Power Rating for 3 Phase Motor at 415V		Reference	MRP (₹)	Independent Mounting Kit	MOQ
	HP	KW				
0.10-0.16	*	*	LR1D09301	2320	Reference LA7-D0964 MRP ₹ 400 [HSN Code: 8538]	10
0.16-0.25	*	*	LR1D09302			
0.25-0.40	*	*	LR1D09303			
0.40-0.63	*	*	LR1D09304			
0.63-1.00	0.5	0.37	LR1D09305			
1.00-1.60	0.75	0.55	LR1D09306			
1.60-2.50	1.5	1.10	LR1D09307			
2.50-4.00	2.00	1.50	LR1D09308			
4.00-6.00	3.00	2.20	LR1D09310			
5.50-8.00	5.00	3.70	LR1D09312			
7.00-10.0	5.50	4.00	LR1D09314	2780	Reference LA7-D3264 MRP ₹ 560 [HSN Code: 8538]	
10.0-13.0	7.50	5.50	LR1D12316			
13.0-18.0	12.00	9.00	LR1D16321			
18.0-25.0	15.00	11.00	LR1D25322			
23.0-32.0	20.00	15.00	LR1D32353	3990	Reference LA7-D4054 MRP ₹ 750 [HSN Code: 8538]	
28.0-40.0	20.00	15.00	LR1D32355			
23.0-32.0	20.00	15.00	LR1D40353	4390	Reference LA7-D4054 MRP ₹ 750 [HSN Code: 8538]	
30.0-40.0	30.00	22.00	LR1D40355			
38.0-50.0	35.00	25.00	LR1D63357	5070		
48.0-57.0	40.00	30.00	LR1D63359	7200		
57.0-66.0	50.00	37.00	LR1D63361	7940		

* There is no standard power rating for these motors. Select the overload relay in relation to the full load current.

AC Coil Voltage Codes for D Range Contactors (Non-Standard)

Contactor	Voltage		
	42	360	380
LC1-D	D	UW	Q

For Non-Standard Coil Voltage, please add ₹ 200/- in the MRP.

Thermal OLR Type LR1-Independent Mounting [HSN Code: 8536]

Relay Setting Range A	Std. Power Rating for 3 Phase Motor at 415V		Reference	MRP (₹)	MOQ
	HP	KW			
66.0 to 80.0	60	45	LR1-D80363	7900	1

Consisting of 1 NO+1 NC make before break contacts.

AC Coil Voltage Codes for D Range Contactors (Standard)

Contactor	Voltage					
	24	48	110*	220*	240*	415*
LC1-D	B	E	F	M	U	N

* Coils also available in wide band. * Stock for accessories are subject to availability

Accessories

Global Certification



Add-on-Blocks for D Range Contactors

[HSN Code: 8538]

Contactor		Reference	MRP (₹)	MOQ	
Additional Instantaneous Aux.Contact Blocks	Front Mounted	2 NO	LA1D20	570	
		1 NO+1 NC	LA1D11		
		2 NC	LA1D02		
		860	4 NO	LA1D40	
			3 NO+1 NC	LA1D31	
			2 NO+2 NC	LA1D22	
			1 NO+3 NC	LA1D13	
			4 NC	LA1D04	
Overlapping Aux. Contacts	Front Mounted	2 NO+2 NC	LA1D1111#	1220	10

D Range Mechanical Interlocks Horizontally Mounted

[HSN Code: 8538]

Use for Contactor AC	Reference	MRP (₹)	MOQ
LC1-D09	LA9-D09978	790	10
LC1-D12			
LC1-D17			
LC1-D22			
LC1-D25			
LC1-D32			
LC1-D40	LA9-D50978	1950	
LC1-D50			
LC1-D63			
LC1-D80	LA9-D80978	2560	

■ Please specify Coil Voltage by indicating the Coil Voltage required.

** Spare Moulded Base for these Coils has Product code LA7-D40 and unit price is ₹230

Coil Suppressor

[HSN Code: 8538]

Description	Reference	MRP (₹)	MOQ
For mounting across coil of contactor upto 80Amp, with C network suitable for <250V AC & <400V AC	LA9-D09980	860	10



Add-on Starting Switch

NO starting Switch suitable for direct mounting on Control Relays & Contactors	LA9-D09906	280	10
--	------------	-----	----

Mechanical Latching Blocks

Description for Contractors/Control Relays Type	Reference	MRP (₹)	MOQ
CA2-DN1 LC1-D09, LC1-D12 LC1-D17, LC1-D25, LC1-D32	LA6-DK01 ■	3450	10

■ Replace by voltage code

AC Coil Voltage Codes (Standard)

For Mechanical Latching Block	Voltage							
	24	48	72	110	220	240	380	415/440
LA6-DK01	B	E	EN	F	M	U	Q	N

* Stock for accessories are subject to availability



Contactors - 4 Pole & 2 Pole, AC

Conforming IEC60947-1, IEC60947-4-1

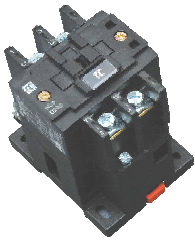

Contactors - 2 Pole AC [HSN Code: 8536]

AC1 Duty	AC3 220V AC		Reference	MRP (₹)	MOQ
	A				
32	20		AC2-D202	1840	2
40	25		AC2-D252	2510	
40	40		AC2-D402	3430	

■ Please specify Coil Voltage.

AC Coil Voltage Codes (Standard) for 2 Pole Contactors

Contactor 2P	Voltage		
	220*	220/240*	380 / 415*
AC2-D2/D3/D4	M5W	MU	QN

* Wide band Coils ■ Please specify Coil Voltage.

Spare Coil for 2 Pole Contactors [HSN Code: 8538]

Reference	Coil Voltage	MRP (₹)	MOQ
AX1D2 MU	220/240V, 50Hz	550	5
AX1D2 M	220V, 50Hz		
AX1D2 QN	380/415V, 50Hz		
AX1D2 N	415V, 50Hz		

Spare Contact Kit for 2 Pole Contactor

AC5D202	20A Contact Kit, 2-Pole	820	1
AC5D252	25A Contact Kit, 2-Pole	1640	
AC5D402	40A Contact Kit, 2-Pole	1990	
☒ AC5D2011	20A Contact Kit, 1NO+1NC	860	

Add-on-Blocks for 2 Pole Contactors

Description	Contact Configuration	Reference	MRP (₹)	MOQ
Front mounted Aux. contact Block	2 NO	LA1-D20A	580	20
	1 NO+1 NC	LA1-D11A		
	2 NC	☒ LA1-D02A		

Thermal OLR 2 Pole type LR7D-Direct Mounting [HSN Code: 8536]

Relay Setting Range (A)	Reference	MRP (₹)	Independent Mounting Kit	MOQ
4.0-6.0	LR7D09210	870	LA7D0964 MRP ₹400 [HSN Code: 8538]	1
5.5-8.0	LR7D09212			
7.0-10	LR7D09214			
9.0-14	LR7D12216X	1050		
13-18	LR7D16221			
14-22	LR7D16221X			
18-25	LR7D25222	1270		
23-32	LR7D32253			



Contactors - 4 Pole AC [HSN Code: 8536]

AC3, 415V			Main Poles Configuration	Reference	MRP (₹)	MOQ
kW	HP	A				
7.5	10	20	4NO	TC1DX204	4720	1
11	15	25	4NO	TC1DX254	6930	
22	30	40	4NO	TC1DX404	11270	

■ Please specify Coil Voltage.

AC Coil Voltage Codes (Standard) for 4 Pole Contactors [HSN Code: 8536]

Contactor 4P	Voltage			
	110	220	190-400	250-450
TC1-DX204/254	F	M	Q	N

Spare Coil for 4 Pole Contactors

Reference	Coil Voltage	MRP (₹)	MOQ
TX1D20	110/220/190-400/250-450	800	1

Spare Contact Kit for 4 Pole Contactor

TA5DX204	20A Contact Kit, 4-Pole	1530	1
TA5DX254	25A Contact Kit, 4-Pole	2650	
TA5DX404	40A Contact Kit, 4-Pole	4300	

Mechanical Interlock for 4 Pole Contactors

LA9-D0978	Horizontal Mounted	750	10
-----------	--------------------	-----	----

Add-on-Blocks for 4 Pole Contactors

Description	Contact Configuration	Reference	MRP (₹)	MOQ
Front mounted Aux. contact Block	1 NO+1 NC	TA1-DN11A	620	2

Note : Also available with 2NC.

Exceed Definite Purpose Contactor

Conforming IEC60947-1, IEC60947-4-1



Single Pole (Without Shunt) [HSN Code: 8536]

Full load (inductive) (A)	Locked Rotor Per Pole (A) AC 240V/AC 277V	Resistive Rating (A)	Reference	MRP (₹)
25	150	30	TCDPE251-XX	1120
20	150	30	TCDPE201-XX	1010

Single Pole (With Shunt)

25	150	30	TCDPE251S-XX	1170
20	150	30	TCDPE201S-XX	1010

Two Pole

20	120	30	TCDPE202-XX	1280
25	150	35	TCDPE252-XX	1360

Note: Replace XX with coil voltage code

Exceed DP Contactor Coil Single Pole (with & without Shunt)

50Hz		60Hz	
Voltage	Reference	Voltage	Reference
145-180V	H5	24V	B6
220V	M5	120V	G6
240V	U5	208V	L6
24V	B5	220V	M6
277V	W5	240V	U6
380V	Q5	277V	W6
415V	N5	480V	T6
180-215V	M5W	-	-
170-240V	L5W	-	-

Exceed DP Contactor Coil Two Pole

50Hz		60Hz	
Voltage	Reference	Voltage	Reference
145-180V	H5	24V	B6
220V	M5	120V	G6
240V	U5	208V	L6
415V	N5	220V	M6
24V	B5	240V	U6
120V	G5	277V	W6
277V	W5	480V	T6
170-240V	L5W	-	-



Definite Purpose Contactor

Conforming IEC60947-1, IEC60947-4-1

Global Certification



RoHS
Compliant



Contactor				[HSN Code: 8536]
FLA	Resistive AMP Rating	Reference	MRP (₹)	MOQ
Single Pole (Without Shunt)				
25	30	<input checked="" type="checkbox"/> TCDP251	1300	1
30	40	<input checked="" type="checkbox"/> TCDP301	1380	
40	50	<input checked="" type="checkbox"/> TCDP401	1450	
Single Pole (With Shunt)				
25	30	TCDP251S	1360	1
30	40	TCDP301S	1430	
40	50	TCDP401S	1550	
Two Pole				
20	30	TCDP202	1490	1
30	40	TCDP302	1500	
40	50	<input checked="" type="checkbox"/> TCDP402	1610	
Three Pole				
20	30	TCDP203	1770	1
30	40	TCDP303	1810	
40	50	<input checked="" type="checkbox"/> TCDP403	2060	

AC Coil Voltage Codes for Definite Purpose Contactors

Voltage	24VAC	110VAC	240VAC
50Hz	B5	G5	U5
60Hz	B6	G6	U6

DT-Series 4 Pole Rating AC1 25A-63A

[HSN Code: 8536]

AC1 Duty A	Main Pole Configuration	With AC Coil		MOQ
		Reference	MRP (₹)	
25	4 NO	TC1DT254Ne	POR	1
32	4 NO	<input checked="" type="checkbox"/> TC1DT324Ne		
32	2 NO+2 NC	TC1DT328Ne		
40	4 NO	<input checked="" type="checkbox"/> TC1DT404Ne		
50	4 NO	TC1DT504Ne		
45	4 NO	TC1DT45004E		
45	2 NO+2 NC	TC1DT45008E		
50	4 NO	TC1DT50004E		
50	2 NO+2 NC	TC1DT50008E		
63	4 NO	TC1DT63004E		
63	2 NO+2 NC	TC1DT63008E		

AC Coil for 4 Pole Telecom Contactor

Contactor	Voltage			
TC1-DT**Ne	230	235	240	415
50Hz	P	C5W	M	N

All coils codes applicable for extra wide band coils.

* Stock for accessories are subject to availability

Non Stockable item

MOQ- Minimum Order Quantity

Industrial Plugs & Sockets



Benefits

- Safety through interchangeability
- High grade thermo plastic material assured:
 - Exceptional high impact resistance
 - High thermal stability
 - High insulated Quality
 - Good resistance to various chemicals
- Colour codes for easy identification of Plug & Sockets
- Locking device prevent unintended withdrawal

IEC 60309 Series
P44 & P67 Protection

Position of the Earthing Contact



30A

Position of the Earthing Contact



63A



Control & Singnalling Devices

Metallic & Polycarbonate Series



Push Buttons & Pilot Lamps

- Ø22.5 mm Push Buttons, Emergency Stop PB, Selector switch
- Illuminated & Non Illuminated Actuators in Plastic & Metallic variants
- Pilot Lamps in LED / Filament / Neon types
- Push Button Stations 1/2/3/4 ways, IP65 / 166, NEMA-41/X protection
- High Mechanical and Electrical life
- Aesthetic and Elegant outlook
- Wide Range of colors / voltages available

Globally accepted



IEC 60309 Series

[HSN Code: 8536]

IP 44 & IP 67 Versions	Description	Rating (Amp)	Protection Degree	3 PIN, 2P+E 240V AC			4 PIN, 3P+E 415V AC			5 PIN, 3P+N+E 415V AC		
				Code	MRP (₹)	Reference h	Code	MRP (₹)	Reference h	Code	MRP (₹)	Reference h
	Panel Mounting Socket - Splash Proof	16	IP44	CS62205*	750	6	-	-	-	CS62210*	1250	6
		32		CS62216*	1280	6	-	-	-	CS62221*	1440	6
	Panel Mounting Socket - Water Tight	16	IP67	CS62227	1610	6	-	-	-	CS62232	1720	6
		32		CS62238	1740	6	-	-	-	CS62243	2280	6
		63		☒CS63249	6400	6	-	-	-	CS63254	5880	6
		125		-	-	-	-	-	-	CS62262	22010	6
	Surface Mounting Socket - Splash Proof	16	IP44	CS62404	1240	6	-	-	-	CS62409	1360	6
		32		CS62415	1540	6	-	-	-	CS62420	1620	6
	Surface Mounting Socket - Water Tight	16	IP67	CS62426	2100	6	-	-	-	☒CS62431	2750	6
		32		☒CS62437	2620	6	☒CS62283	2940	3	CS62442	3150	6
		63		☒CS63448	8070	6	-	-	-	CS63453	8270	6
		125		-	-	-	-	-	-	☒CS63463	28510	6
	Plugs - Splash Proof	16	IP44	CS60004*	650	6	-	-	-	CS60009*	870	6
		32		CS60015*	1040	6	-	-	-	CS60020*	1250	6
	Plugs - Water Tight	16	IP67	CS60026	1390	6	-	-	-	CS60031	1830	6
		32		CS60037	2150	6	CS60145	2200	3	CS60042	2240	6
		63		☒CS61048	6080	6	-	-	-	CS61053	6290	6
		125		-	-	-	-	-	-	CS60061	18680	6
	Surface Mounting Interlocked Switched Socket Outlet - Horizontal	16	IP44	CS66004(H)	9860	6	-	-	-	☒CS66109(H)	12570	6
		32		☒CS66015(H)	11730	6	-	-	-	☒CS66020(H)	14050	6
	Surface Mounting Interlocked Switched Socket Outlet - Vertical	16	IP67	CS66200	10810	6	-	-	-	☒CS66202	15300	6
		32		☒CS66201	15090	6	-	-	-	☒CS66203	18250	6
	Connector - Splash Proof	16	IP44	CS62004*	940	6	-	-	-	☒CS66215*	1080	-
		32		CS62015*	1200	6	-	-	-	CS66225*	1530	-
	Connector Water Tight	32	IP67	-	-	-	CS62128	2940	3	-	-	

Note: Plugs & Sockets 3 PIN, 2P+E 240V AC are in Blue color, 5 PIN, 3P+N+E 415V AC are in Red color

[HSN Code: 8536]

AC Distribution Box with Socket	Description	Rating (Amp)	Protection Degree	Code	MRP (₹)	Reference h
	AC Distribution Box (Includes Socket & Plug)	16A 3P 240V	IP40	CS60045*	2330	6
		32A 3P 240V		CS60046*	2880	6
		32A 5P 415V		CS60047*	4330	6
		63A 5P 415V		CS60048*	11260	6

* Stock for accessories are subject to availability



Push Buttons: 22.5mm
Without Contact Elements

Global Certification |

Push Button Actuators with Carrier-Non-Illuminated [HSN Code: 8536]

Description	Reference	MRP (₹)	Std. Pkg. (Nos.)	Product Picture
Push Spring Return Push Button	<input checked="" type="checkbox"/> RCP2-BA2●	140	20	
	RCP2-BA3●			
	RCP2-BA4●			
	RCP2-BA5●			
	<input checked="" type="checkbox"/> RCP2-BA6●			
Flush Spring Return Push Button with contact	<input checked="" type="checkbox"/> RCP2BA33●	300	10	
	RCP2BA35●			
Projecting Push Button	RCP2-BL1○	140	10	
	RCP2-BL2●			
	RCP2-BL3●			
	RCP2-BL4●			
	RCP2-BL5●			
	RCP2-BL6●			
Mushroom Head Push Button, Spring Return	RCP2-BC2●	190	8	
	RCP2-BC3●			
	<input checked="" type="checkbox"/> RCP2-BC4●			
	RCP2-BC5●			
	RCP2-BC6●			
Mushroom Head Push Button, Spring Return with contact	RCP2-BC21●	280	10	
	RCP2-BC31●			
	<input checked="" type="checkbox"/> RCP2-BC42●			
	RCP2-BC51●			
	RCP2-BC61●			
Mushroom Head ∅40mm Push Button Stay Put turn to release	RCP2BS54●	260	8	
Mushroom Head ∅40mm Push Button Stay Pull to release	RCP2BT4●			
Mushroom Head ∅60mm Push Button Stay Put turn to release	RCP2BS64●	380	5	
Mushroom Head Push Button, Push to Stay & Key to release	RCP2BS14●	470	8	
Push Button Stay Put ∅30mm (Press to Lock turn to release)	RCP2BS44●	240	10	

Push Button Actuators with Carrier & Contact Element-Non-Illuminated

Flush Spring Return Push Button with 1NO Block	<input checked="" type="checkbox"/> RCP2-BA11○	200	10	
	<input checked="" type="checkbox"/> RCP2-BA21●			
	RCP2-BA31●			
	RCP2-BA51●			
	RCP2-BA61●			
	RCP2-BA41●			
Push Button with 1NC Block	RCP2-BA42●			
Projecting Head Push Button with 1NO Block	RCP2-BL11○	200	10	
	RCP2-BL21●			
	<input checked="" type="checkbox"/> RCP2-BL31●			
	RCP2-BL51●			
	RCP2-BL61●			
Projecting PB with 1NC Block	<input checked="" type="checkbox"/> RCP2-BL42●			

LED Type Push Button Actuators - Illuminated Flush

Flush Illuminated with Integral Circuit LED 48V, 24V & 12V (AC/DC) also available in 110V AC, 110V DC, 240V AC, 220DC	RCP2-BWL317▲○	380	10	
	RCP2-BWL337▲●			
	<input checked="" type="checkbox"/> RCP2-BWL347▲●			
	<input checked="" type="checkbox"/> RCP2-BWL357▲●			
	<input checked="" type="checkbox"/> RCP2-BWL377▲○			
	RCP2-BWL387▲●			
	RCP2-BWL367▲●	660		

Push Button Actuator-Illuminated Projecting without Series Resistor

LED Type Push Button Actuators - Illuminated Projecting
Type of voltage AC/DC to be specified

Projecting Illuminated Actuator, with integral LED, suitable for operating 48V, 24V & 12V (AC/DC) also available in 110V AC, 110V DC, 240V AC, 220DC	RCP2-BWL117▲○	380	10	
	<input checked="" type="checkbox"/> RCP2-BWL137▲●			
	<input checked="" type="checkbox"/> RCP2-BWL147▲●			
	RCP2-BWL157▲●			
	RCP2-BWL177▲○			
	RCP2-BWL187▲●			
	RCP2-BWL167▲●	670		

Colour Code for Actuator / Lens

Colour Code	1	2	3	4	5	6	7	8
Colour of Actuator	White ○	Black ●	Green ●	Red ●	Yellow ●	Blue ●	-	-
Colour of Lens	White ○	-	Green ●	Red ●	Amber ●	Blue ●	Clear ○	Yellow ●

Push Buttons: 22.5mm Without Contact Elements

Global Certification |

Selector Switch Actuators with Carrier [HSN Code: 8536]

Description	Reference	MRP (₹)	Std. Pkg. (Nos.)	Product Picture
2-Position Selector Switch (stay put)	RCP2-BD2	370	10	
3-Position Selector Switch, centre 'OFF' (stay put)	RCP2-BD3			
2-Position Selector Switch with extra long knob (stay put)	<input checked="" type="checkbox"/> RCP2-BJ2	370	10	
3-Position Selector Switch, with extra long knob centre 'OFF' (stay put)	RCP2-BJ3			
3-Position Selector Switch (Spring Return)	RCP2-BDR3	390	10	
3-Position Selector Switch extra long knob (Spring Return)	<input checked="" type="checkbox"/> RCP2-BJR3	390	10	

Selector Switch Actuators with Carrier & Contact Element

2-Position Selector Switch (stay put) with 1NO Block	<input checked="" type="checkbox"/> RCP2-BD21	420	10	
2-Position Selector Switch, centre 'OFF' (stay put) with NO+NC Block	RCP2-BD25	510		
3-Position Selector Switch, centre 'OFF' (stay put) with NO+NC Block	RCP2-BD35			

Key Actuators with Carrier

2-Position Key Switch, Key removable in unactuated position	<input checked="" type="checkbox"/> RCP2-BG2	530	10	
2-Position Key Switch, Key removable in both position	<input checked="" type="checkbox"/> RCP2-BG4			
2-Position Key Switch, Key removable in 'Right Hand' position	RCP2-BG02	540	10	
3-Position Key Switch, Key removable in centre 'OFF' position	<input checked="" type="checkbox"/> RCP2-BG3			
3-Position Key Switch, Key removable in all position	RCP2-BG0			
3-Position Key Switch, Key removable in 'Left Hand & Right Hand' position	RCP2-BG5			
3-Position Key Switch, Key removable in 'Left Hand' position	<input checked="" type="checkbox"/> RCP2-BG9			
3-Position Key Switch, Key removable in 'Right Hand' position	RCP2-BG7			

Push Buttons Extended Range [HSN Code: 8536]

Description	Reference	MRP (₹)	Std. Pkg. (Nos.)	Product Picture
Intermittent Sounding Flashing Buzzer 15 ~ 20 mA, sound level 80 dB.24V, 48V, 110V AC/DC 240V AC (* Add Voltage code)	<input checked="" type="checkbox"/> RB2-KS●	400	15	

LED Type Pilot Lamp Type of voltage AC / DC to be specified

Pilot Light with integral circuit LED 48V, 24V & 12V (AC/DC) also available in 110V AC, 110V DC, 240V AC, 220DC	<input checked="" type="checkbox"/> RCP2-BVL73▲●	350	10	
	<input checked="" type="checkbox"/> RCP2-BVL74▲●			
	<input checked="" type="checkbox"/> RCP2-BVL75▲●			
	RCP2-BVL77▲○			
	RCP2-BVL71▲○			
	<input checked="" type="checkbox"/> RCP2-BVL78▲●			
<input checked="" type="checkbox"/> RCP2-BVL76▲●	620			

How to Order:

Actuators, Contact Elements, Lens Assemblies can also be ordered separately or in combination, as required.

▲ Add Voltage Code

Non Stockable item

NOTE: For contact elements NO/NC please refer page no. 77.

Push Buttons Extended Range

Reset Extended Actuator Push-button - Round Type	<input checked="" type="checkbox"/> RCB2AL8R	130	24	
Reset Extended Actuator Pushbutton - Hex Type	<input checked="" type="checkbox"/> RCB2AL8H	130	30	
Plastic Adaptor for 30 mm hole to 22.5 mm.	<input checked="" type="checkbox"/> RP2-BZ41M	45	20	
Metal Adaptor for 30 mm hole to 22.5 mm	<input checked="" type="checkbox"/> RB2-BZ41M			
Recess (Guarded) Push button - Plastic	RP2-BA16 ○	110	20	
	RP2-BA26 ●			
	<input checked="" type="checkbox"/> RP2-BA36 ●			
	<input checked="" type="checkbox"/> RP2-BA46 ●			
	RP2-BA56 ●			
	RP2-BA66 ●			



Push Buttons: 22.5mm

Metallic Range (Without Contact Elements)

Global Certification |

Push Button Actuators with Carrier-Non-Illuminated [HSN Code: 8536]

Description	Reference	MRP (₹)	Std. Pkg. (Nos.)	Product Picture
Flush Spring Return Push Button	RCB2-BA1 ○	150	20	
	RCB2-BA2 ●			
	RCB2-BA3 ●			
	RCB2-BA4 ●			
	RCB2-BA5 ●			
	RCB2-BA6 ●			
Projecting Push Button	RCB2-BL1 ○	150	10	
	RCB2-BL2 ●			
	RCB2-BL3 ●			
	RCB2-BL4 ●			
	RCB2-BL5 ●			
	RCB2-BL6 ●			
Booted Push Button	RCB2-BP2 ●	210	20	
	RCB2-BP3 ●			
	RCB2-BP4 ●			
	RCB2-BP5 ●			
	RCB2-BP6 ●			
	RCB2-BP6 ●			
Mushroom Head Push Button, Spring Return	RCB2-BC2 ●	210	8	
	RCB2-BC3 ●			
	RCB2-BC4 ●			
	RCB2-BC5 ●			
Mushroom Head Push Button Stay Put (press to lock, turn to release)	RCB2-BS54 ●	290	8	
	RCB2-BS64 ●	380	5	
Mushroom Head Push Button, Push to Stay & Pull to release	RCB2-BT4 ●	340	8	
Mushroom Head Push Button, premarked Pull to Reset	RCB2-BT43 ●			
Mushroom Head Key Switch, StayPut, Key removable in both positions (press to lock and key to release)	RCB2-BS14 ●	590	8	
Push Button Stay Put (press to lock, turn to release)	RCB2-BS44 ●	280	10	

LED Type Push Button Actuators - Illuminated Flush [HSN Code: 8536]

Description	Reference	MRP (₹)	Std. Pkg. (Nos.)	Product Picture
Flush Illuminated Actuator, with integral circuit LED 48V, 24V & 12V (AC/DC) also available in 110V AC, 110V DC, 240V AC, 220DC	RCB2-BWL337 ▲ ●	420	10	
	RCB2-BWL347 ▲ ●			
	RCB2-BWL357 ▲ ●			
	RCB2-BWL317 ▲ ○			
	RCB2-BWL377 ▲ ●			
	RCB2-BWL387 ▲ ●			
	RCB2-BWL367 ▲ ●	690		

Push Button Actuators - Illuminated Projecting with Series Resistor

Description	Reference	MRP (₹)	Std. Pkg. (Nos.)	Product Picture
Illuminated Actuator, Projecting (with BA9S Filament Bulb, 130V) 220VAC/DC	RCB2-BW117 ▲ ○	290	10	
	RCB2-BW137 ▲ ●			
	RCB2-BW147 ▲ ●			
	RCB2-BW157 ▲ ●			
	RCB2-BW167 ▲ ●			
	RCB2-BW177 ▲ ○			

LED Type Push Button Actuators - Illuminated Projecting Type of voltage AC/DC to be specified

Description	Reference	MRP (₹)	Std. Pkg. (Nos.)	Product Picture
Projecting Illuminated Actuator, with integral circuit LED 48V, 24V & 12V (AC/DC) also available in 110V AC, 110V DC, 240V AC, 220DC	RCB2-BWL137 ▲ ●	420	10	
	RCB2-BWL147 ▲ ●			
	RCB2-BWL157 ▲ ●			
Projecting Illuminated Actuator, with integral circuit LED 48V, 24V & 12V (AC/DC) also available in 110V AC, 110V DC, 240V AC, 220DC	RCB2-BWL167 ▲ ●	800		

Double Push Button Actuators - Illuminated Flush without Series Resistor

Description	Reference	MRP (₹)	Std. Pkg. (Nos.)	Product Picture
Illuminated Double Push Button, Flush Green & Red Knob marked I&O respectively (with BA9S Neon Bulb) 220V, 380V, 415VAC/DC	RCB2-BWN96 ▲	480	8	

Push Button Actuators with Carrier & Contact Element-Non-Illuminated

Description	Reference	MRP (₹)	Std. Pkg. (Nos.)	Product Picture
Flush Spring Return Push Button with 1NO Block	RCB2-BA11 ○	250	10	
	RCB2-BA21 ●			
	RCB2-BA31 ●			
	RCB2-BA51 ●			
	RCB2-BA61 ●			
	RCB2-BA41 ●			
Push Button with 1NC Block	RCB2-BA42 ●			
Push Button with 2NO Block	RCB2-BA33 ●	360		
Projecting Head Push Button with 1NO Block	RCB2-BL11 ○	250	10	
	RCB2-BL21 ●			
	RCB2-BL31 ●			
	RCB2-BL51 ●			
Projecting PB with 1NC Block	RCB2-BL42 ●			
Mushroom Head Push Button Stay Put (press to lock, turn to release) with 1NC Block	RCB2-BS542 ●	400	8	
	RCB2-BS642 ●	470	4	

* Stock for accessories are subject to availability Non Stockable item



Push Buttons: 22.5mm

Metallic Range (Without Contact Elements)





Global Certification |  US LISTED  

Description	Reference	MRP (₹)	Std. Pkg. (Nos.)	Product Picture
-------------	-----------	---------	------------------	-----------------

Push Button Actuators with Carrier - Non-Illuminated [HSN Code: 8536]

Double Push Button, Flush Green & Red Knob marked I&O respectively	RCB2-BA87 	250	10	
--	---	-----	----	---

Selector Switch Actuators with Carrier









2-Position Selector Switch (stay put)	RCB2-BD2 RCB2-BD27*	410	10	
3-Position Selector Switch, centre 'OFF' (stay put)	RCB2-BD3 RCB2-BD37*			
2-Position Selector Switch with extra long knob (stay put)	RCB2-BJ2 <input checked="" type="checkbox"/> RCB2-BJ27*	420	10	
3-Position Selector Switch, with extra long knob centre 'OFF' (stay put)	RCB2-BJ3 <input checked="" type="checkbox"/> RCB2-BJ37*			
2-Position Selector Switch (Spring Return)	RCB2-BDR2 <input checked="" type="checkbox"/> RCB2-BDR27*	460	10	
3-Position Selector Switch (Spring Return)	RCB2-BDR3 RCB2-BDR37*			
2-Position Selector Switch extra long knob (Spring Return)	<input checked="" type="checkbox"/> RCB2-BJR2 RCB2-BJR27*	460	10	
3-Position Selector Switch extra long knob (Spring Return)	<input checked="" type="checkbox"/> RCB2-BJR3 RCB2-BJR37*			

Selector Switch Actuators with Carrier & Contact Element [HSN Code: 8536]

2-Position Selector Switch (stay put) with 1NO Block	RCB2-BD21 <input checked="" type="checkbox"/> RCB2-BD271*	490	10	 +
2-Position Selector Switch, centre 'OFF' (stay put) with NO+NC Block	RCB2-BD25 <input checked="" type="checkbox"/> RCB2-BD275*	600		
3-Position Selector Switch, centre 'OFF' (stay put) with NO+NC Block	RCB2-BD35 <input checked="" type="checkbox"/> RCB2-BD375*			









*with Black Bezel

Selector Switch Actuators-Illuminated with Series Resistor [HSN Code: 8536]

2-Position Illuminated Selector Switch (with BA9S Filament Bulb 130V) suitable for operation at 220V AC/DC	<input checked="" type="checkbox"/> RCB2-BK1237 	650	10	
	<input checked="" type="checkbox"/> RCB2-BK1247 			
	<input checked="" type="checkbox"/> RCB2-BK1257 			
3-Position Illuminated Selector Switch (with BA9S Filament Bulb 130V) suitable for operation at 220V AC/DC	<input checked="" type="checkbox"/> RCB2-BK1337 	650	10	
	<input checked="" type="checkbox"/> RCB2-BK1347 			
	<input checked="" type="checkbox"/> RCB2-BK1357 			

Selector Switch Actuators-Illuminated with integral circuit LED available on request





Selector Switch Actuators - Illuminated without series resistor

2-Position Illuminated Selector Switch (with LED Bulb) 48V, 24V & 12V (AC/DC) also available in 110V AC, 110V DC, 240V AC, 220DC	<input checked="" type="checkbox"/> RCB2BKL1237 	650	10	
	<input checked="" type="checkbox"/> RCB2BKL1247 			
	<input checked="" type="checkbox"/> RCB2BKL1257 			
3-Position Illuminated Selector Switch (with LED Bulb) 48V, 24V & 12V (AC/DC) also available in 110V AC, 110V DC, 240V AC, 220DC	<input checked="" type="checkbox"/> RCB2BKL1337 	650	10	
	<input checked="" type="checkbox"/> RCB2BKL1347 			
	<input checked="" type="checkbox"/> RCB2BKL1357 			



* Stock for accessories are subject to availability. Non Stockable item

Description	Reference	MRP (₹)	Std. Pkg. (Nos.)	Product Picture
-------------	-----------	---------	------------------	-----------------

Key Actuators with Carrier [HSN Code: 8536]



2-Position Key Switch, Key removable in unactuated position	RCB2-BG2 RCB2-BG27*	590	10	
2-Position Key Switch, Key removable in both position	RCB2-BG4 RCB2-BG47*			
2-Position Key Switch, Key removable in 'Right Hand' position	<input checked="" type="checkbox"/> RCB2-BG02 <input checked="" type="checkbox"/> RCB2-BG027*	610	10	
3-Position Key Switch, Key removable in centre 'OFF' position	RCB2-BG3 RCB2-BG37*			
3-Position Key Switch, Key removable in all position	<input checked="" type="checkbox"/> RCB2-BG0 RCB2-BG0-7*	610	10	
3-Position Key Switch, Key removable in 'Left Hand & Right Hand' position	<input checked="" type="checkbox"/> RCB2-BG5 RCB2-BG57*			
3-Position Key Switch, Key removable in 'Left Hand' position	RCB2-BG9 RCB2-BG97*	610	10	
3-Position Key Switch, Key removable in 'Right Hand' position	<input checked="" type="checkbox"/> RCB2-BG09 RCB2-BG097*			
3-Position (Spring Return) Key Switch, Key removable in 'Center' position	<input checked="" type="checkbox"/> RCB2-BG7 RCB2-BG77*	610	10	

Key Actuators with Carrier & Contact element

2-Position Key Switch with 1NO Block, Key removable in unactuated position	<input checked="" type="checkbox"/> RCB2-BG21 RCB2-BG271*	640	10	 +
2-Position Key Switch with 1NO Block, Key removable in both position	<input checked="" type="checkbox"/> RCB2-BG41 RCB2-BG471*			
3-Position Key Switch with 1NO+1NC Block key removable in centre 'OFF' position	<input checked="" type="checkbox"/> RCB2-BG31 RCB2-BG371*	760	10	
3-Position Key Switch with 1NO+1NC Block key removable in all position	RCB2-BG04 RCB2-BG074*			

* with Black Bezel

Contact Elements - NO/NC (Non UL)* [HSN Code: 8536]

Contact Element 1 NO	RE2BE101	100	50	
Contact Element 1 NC	RE2BE102			
Contact Element 1 NO	RB2-BE-101	120	50	
Contact Element 1 NC	RB2-BE-102			

*Applicable for Both Metallic and Plastic range

How to Order:

Actuators, Contact Elements, Lens Assemblies can also be ordered separately or in combination, as required.

▲ Add Voltage Code



Pilot Lamps: 22.5mm
Metallic Range

Global Certification

Description	Reference	MRP (₹)	Std. Pkg. (Nos)	Product Picture
LED Type Pilot Lamp-Type of voltage AC/DC [HSN Code: 8536]				
Pilot Light with integral circuit LED 48V, 24V & 12V (AC/DC) also available in 110V AC, 110V DC, 240V AC, 220DC	<input checked="" type="checkbox"/> RCB2BVL71▲○	380	10	
	<input checked="" type="checkbox"/> RCB2BVL73▲●	380		
	<input checked="" type="checkbox"/> RCB2BVL74▲●			
	<input checked="" type="checkbox"/> RCB2BVL75▲●			
	RCB-BVL77▲○			
	<input checked="" type="checkbox"/> RCB2BVL78▲●			
	<input checked="" type="checkbox"/> RCB2BVL76▲●	760		

Economical Barrel LED Series - Type of voltage AC/DC				
Suitable for operating at 12V DC, 240V AC, 415V AC AC/DC-24V, 110V, 220V	RCN7-IVL71▲○	390	15	
	<input checked="" type="checkbox"/> RCN7-IVL76▲●			
	RCN7-IVL73▲●	210		
	RCN7-IVL74▲●			
	<input checked="" type="checkbox"/> RCN7-IVL75▲●			
	<input checked="" type="checkbox"/> RCN7-IVL77▲○			
	<input checked="" type="checkbox"/> RCN7-IVL78▲●			

Colour Code for Actuator / Lens

Colour Code	1	2	3	4	5	6	7	8
Colour of Actuator	White ○	Black ●	Green ●	Red ●	Yellow ●	Blue ●	-	-
Colour of Lens	White ○	-	Green ●	Red ●	Amber ●	Blue ●	Clear ○	Yellow ●

▲ Add Voltage Code

Colour Code for Actuator / Lens

Colour Code	1	2	3	4	5	6	7	8
Colour of Actuator	White ○	Black ●	Green ●	Red ●	Yellow ●	Blue ●	-	-
Colour of Lens	White ○	-	Green ●	Red ●	Amber ●	Blue ●	Clear ○	Yellow ●

▲ Add Voltage Code

* Stock for accessories are subject to availability.

Description	Reference	MRP (₹)	Std. Pkg. (Nos.)	Product Picture
Push Button Powder Coated Actuators with Carrier [HSN Code: 8536]				
Flush Spring Return Push Button powder coated	RCB2-BA17 ○	150	20	
	RCB2-BA27 ●			
	RCB2-BA37 ●			
	RCB2-BA47 ●			
	RCB2-BA57 ●			
	RCB2-BA67 ●			
Projecting Push Button	RCB2-BL17 ○	160	10	
	RCB2-BL27 ●			
	RCB2-BL37 ●			
	RCB2-BL47 ●			
	RCB2-BL57 ●			
	RCB2-BL67 ●			















Integrated LED Pilot Lamp - Type of voltage AC/DC				
Integral LED pilot Lamp suitable for operating at common voltage (AC/DC) 110V, 48V, 24V & 12V Also available at operational voltage 240V AC, 220V DC, 110V AC, 110V DC	<input checked="" type="checkbox"/> RCB7-IVL71▲○	440	15	
	<input checked="" type="checkbox"/> RCB7-IVL76▲●			
	<input checked="" type="checkbox"/> RCB7-IVL73▲●	250		
	<input checked="" type="checkbox"/> RCB7-IVL74▲●			
	<input checked="" type="checkbox"/> RCB7-IVL75▲●			
	<input checked="" type="checkbox"/> RCB7-IVL77▲○			
<input checked="" type="checkbox"/> RCB7-IVL78▲●	750			
RCB7-IVL71▲○				
Wide range: 12V-240V (AC/DC)	RCB7-IVL76▲●	550	15	
	RCB7-IVL73▲●			
	RCB7-IVL74▲●			
	RCB7-IVL75▲●			
	<input checked="" type="checkbox"/> RCB7-IVL77▲○			
	RCB7-IVL78▲●			

Accessories



Metallic Range (For Push Buttons & Pilot Lamps : 22.5mm)

Global Certification   



Operating Heads Without Contact Block and Carrier [HSN Code: 8536]

Description	Reference	MRP (₹)	Std. Pkg. (Nos)	Product Picture
Pilot Lamp Head	RB2-BV01 ○	150	20	
	RB2-BV03 ●			
	RB2-BV04 ●			
	RB2-BV05 ●			
	RB2-BV06 ●			
	RB2-BV07 ○			
	RB2-BV08 ●			
Flush Push Button	RB2-BA1 ○	130	20	
	RB2-BA2 ●			
	RB2-BA3 ●			
	RB2-BA4 ●			
	RB2-BA5 ●			
	RB2-BA6 ●			
Projecting Push Button	RB2-BL1 ○	150	20	
	RB2-BL2 ●			
	RB2-BL3 ●			
	RB2-BL4 ●			
	RB2-BL5 ●			
	RB2-BL6 ●			
Mushroom Spring Return	RB2-BC2 ●	200	8	
	RB2-BC3 ●			
	RB2-BC4 ●			
	RB2-BC5 ●			
Mushroom Stay Put	φ30mm RB2-BS44 ●	250	10	
	φ40mm RB2-BS54 ●	260	8	
	φ60mm RB2-BS64 ●	370	5	
Mushroom illuminated - 2 position Momentary - 2 position Maintained	RCB2-BW43 ●	450	8	
	RCB2-BW44 ●			
	RCB2-BW64 ●			
	RCB2-BW63 ●			
Booted Push Button	RB2-BP2 ●	210	20	
	RB2-BP3 ●			
	RB2-BP4 ●			
	RB2-BP5 ●			
	RB2-BP6 ●			
Double Headed without Light	RB2-BA87 	250	10	
Double Headed Push Button with Light	RB2-BW9 	270		
Illuminated Flush Push Button	RB2-BW31 ○	170	10	
	RB2-BW33 ●			
	RB2-BW34 ●			
	RB2-BW35 ●			
	RB2-BW36 ●			
	RB2-BW37 ○			
Illuminated Projecting Push Button	RB2-BW38 ●	180	10	
	RB2-BW13 ●			
	RB2-BW14 ●			
	RB2-BW15 ●			
	RB2-BW16 ●			
Illuminated Selector 2-Position Stay Put	RB2-BK123 ●	400	10	
	RB2-BK124 ●			
	RB2-BK125 ●			
Illuminated Selector 3-Position Stay Put	RB2-BK133 ●	420	10	
	RB2-BK134 ●			
	RB2-BK135 ●			

Operating Heads LED, Neon Pilot Lamp / Push Button Without Contact Block and Carrier [HSN Code: 8536]

Description	Reference	MRP (₹)	Std. Pkg. (Nos.)	Product Picture
LED Pilot Lamp Head	RB2-BVL01 ○	130	20	
	RB2-BVL03 ●			
	RB2-BVL04 ●			
	RB2-BVL05 ●			
	RB2-BVL06 ●			
	RB2-BVL07 ○			
	RB2-BVL08 ●			
LED Illuminating Flush Push Button	RB2-BWL31 ○	180	10	
	RB2-BWL33 ●			
	RB2-BWL34 ●			
	RB2-BWL35 ●			
	RB2-BWL36 ●			
	RB2-BWL37 ○			
LED Illuminating Projecting Push Button	RB2-BWL38 ●	200	10	
	RB2-BWL11 ○			
	RB2-BWL13 ●			
	RB2-BWL14 ●			
	RB2-BWL15 ●			
	RB2-BWL16 ●			
RB2-BWL17 ○				
RB2-BWL18 ●				

Operating Heads LED, Neon Pilot Lamp / Push Button Without Contact Block and Carrier

Description	Reference	Operating Handle	MRP (₹)	Std. Pkg. (Nos.)	Product Picture
Selector 2-Position, Stay Put	RB2-BD2	Standard	370	10	
Selector 2-Position, Stay Put	RB2-BJ2	Long	400		
Selector 2-Position, Spring Return	RB2-BDR2	Standard	370		
Selector 2-Position, Stay Put	RB2-BJR2	Long	400		
Selector 3-Position, Stay Put (Centre OFF)	RB2-BD3	Standard	370		
Selector 3-Position, Stay Put (Centre OFF)	RB2-BJ3	Long	400		
Selector 3-Position, Spring Return (Centre OFF)	RB2-BDR3	Standard	370		
Selector 3-Position, Stay Put	RB2-BJR3	Long	400		
Key Selector 2-Position, Stay Put	RB2-BG2	Key removable in L.H. position	550		
Key Selector 2-Position, Stay Put	RB2-BG4	Key removable in both positions	550		
Key Selector 2-Position, Stay Put	RB2-BG02	Key removable in R. H. position	550		
Key Selector 2-Position, Spring Return Stay Put	RB2-BG6	Key removable in L.H. position	550		
Key Selector 3-Position, Stay Put	RB2-BG3	Key removable in centre position	550		
Key Selector 3-Position, Stay Put	RB2-BG0	Key removable in all positions	550		
Key Selector 3-Position, Stay Put	RB2-BG5	Key removable in L. H. & R. H. position	550		
Key Selector 3-Position, Stay Put	RB2-BG9	Key removable in L.H. position	560		
Key Selector 3-Position, Stay Put	RB2-BG09	Key removable in R. H. position	560		
Key Selector 3-Position, Both Side Spring Return	RB2-BG7	Key removable in Centre position	560		
Mushroom Head with Key Stay Put	RB2-BS14 ●	Key removable in both positions	560	8	



Accessories

Metallic Range (For Push Buttons & Pilot Lamps : 22.5mm)

Body Assemblies with Contact Blocks, Screw & Captive Clamp Connection [HSN Code: 8536]

Description	Reference	Contact Type	MRP (₹)	Std. Pkg. (Nos.)	Product Picture
For Actuators, Push Buttons, Selectors & Key Switches	RB2-BZ101	NO	180	20	
	RB2-BZ102	NC			
	RB2-BZ103	1NO+1NO	280	10	
	RB2-BZ104	1NC+1NC			
	RB2-BZ105	1NO+1NC			

Description	Reference	MRP (₹)	Std. Pkg. (Nos.)	Product Picture
Set of Lens (one inner and one outer) for Pilot Lamp Head	RB2-BV00*	40	20	
Lens for LED & Neon Type Pilot Lamp (w/o inner lens)	RB2-BVL00*			
Set of Lens (one inner and one outer) for Illuminating Actuator	RB2-BW00*	40	20	
Lens for Illuminating LED & Neon actuator (w/o inner lens)	RB2-BWL00*			
Silicon Cap suitable for, -Booted Push Button (coloured) -Push Buttons Flush (Natural) -Push Buttons Illuminated (Natural)	RB2BP00	40	100	
	RC-S			
	RCL	50		
Legend Plate with inscription (On, Off, Start, Stop, Slow, Fast, Forward, Reverse, Up, Down, Open, Close, Auto, Auto-o-Hand, Auto-Hand, Reset, Inch.)	RB2-BYN#	40	100	
Body / Carrier with mounting screws (passivated) for making different assemblies	RB2-B*	65	20	
Yellow legend (PVC) φ60mm	RB2-PY9330	80	50	
Emergency Stop φ90mm	RB2-PY8330	85	50	

#Minimum Order Qty. will be 500 Nos.

How to Order :

- Actuators, switch elements, lens assemblies can be ordered separately or in combination.
- Basic type designation for actuators is "RB2-B". Numerical colour code is added as a suffix to indicate the colour of the actuator or lens. Remove "*" and put numerical code as indicated below:

Colour Code	1	2	3	4	5	6	7	8
Colour of Actuator	White	Black	Green	Red	Yellow	Blue	-	-
Colour of Lens	White	-	Green	Red	Amber	Blue	Clear	Yellow

- Different suffixes are assigned for flush, projecting, selector actuators etc.
- The type designation for contact element is '1' for NO and '2' for NC.
- Basic type designation for legend plates is "RB2-BY". To complete code with type of inscription please remove "*" and put numerical code as indicated below.

Standard Text	Reference	Standard Text	Reference	MRP (₹)	Std. Pkg. (Nos.)
Start	2303	Stop	2304	40	260
Forward	2305	Reverse	2306		
Up	2307	Down	2308		
On	2311	Off	2312		
Open	2313	Close	2314		
Auto	2315	Hand	2316		
Reset	2323	Inch	2321		
Slow	2327	Fast	2328		
Auto - Hand	2364	Auto-O-Hand	2385		
		Hand-O-Auto	2387		

Important :

- Ordered quantities should be in multiple of standard packing.
- Illuminated Push Buttons & Pilot Lamps will be supplied with bulb only.
- N in product code stands for Neon Bulb.

☒ Non Stockable item.

Control Stations (Assembled)

Complete Control Stations-Start & Stop Functions Plastic, Spring Return [HSN Code: 8536]

Description	Scheme	Colour	Making on legend	Reference	MRP (₹)	Product Picture
1 Flush Push Button	NO	3	I START	RC1P102	890	
				RC1P103		
1 Flush Push Button	NC	4	O STOP	RC1P112		
				RC1P114		
Latching Push Button	NC	4	STOP	RC1PBS542	970	
				RC1PYBS542		
Mushroom Head Key Switch	NC	4	STOP	RC1PBS142	1330	
				RC1PYBS142		
2 Flush Push Button	NO+NC	3	I	RC2P213	1280	
		4	O			
2 Flush Push Button	NO+NC	3	START	RC2P215		
		4	STOP			

Complete Control Stations Directional/Movement Control Functions Plastic, Spring Return

Description	Scheme	Colour	Making on legend	Reference	MRP (₹)	Product Picture
2 Flush Push Button	NO + NO	1	Up Down	RC2P222	1430	
				RC2P222A		
			Right Left	RC2P223		
				RC2P223A		
			Open Close	RC2P241		
				RC2P222B		
3 Flush Push Button	NO + NC + NO	3 4 3	Forward Stop Reverse	RC3P311	1850	
				RC3P321		
			Right Stop Left	RC3P331		
				RC3P341		
			Open Stop Close	RC3P324		
				RC3P334		

Control Stations for Customer Assembly Empty Enclosure, Plastic

Description	Number of Ways	Reference	MRP (₹)	Product Picture
Yellow	1	RC - 1PY	720	
	1	RC - 1P		
Bone Grey	2	RC - 2P	800	
	3	RC - 3P	910	
	4	RC - 4P	1020	

* Empty Enclosure's are available without contact blocks and push buttons and can be assembled with the accessories / spare parts as per specified requirements.

* Stock for accessories are subject to availability



Control Stations (Assembled)

Complete Control Stations-Start and Stop Functions Metal, Spring Return [HSN Code: 8536]

Description	Scheme	Colour	Marking on legend	Reference	MRP (₹)	Product Picture
1 Flush Push Button	NO	3	I START	RC 1M 102	1330	
				RC 1M 103		
1 Flush Push Button	NC	4	O STOP	RC 1M 112		
				RC 1M 114		
Latching Push Button	NC	4	STOP	RC1MBS542	1470	
Mushroom Head Key Switch	NC	4	STOP	RC1MBS142	1700	
2 Flush Push Button	NO+NC	3	I O	RC 2M 213	1680	
				4		

Complete Control Stations Directional/ Movement Control Functions Metal, Spring Return [HSN Code: 8536]

Description	Scheme	Colour	Marking on legend	Reference	MRP (₹)	Product Picture
2 Flush Push Button	NO + NO	1 2	↑ ↓ Up-Down	RC 2M 222	1630	
				RC 2M 222A		
		1 2	↔ Right-Left	RC 2M 223		
				RC 2M 223A		
		1 2	Open-Close Forward-Reverse	RC 2M 241		
				RC2M222B		
3 Flush Push Button	NO + NC + NO	3 4 3	Forward Stop Reverse	RC 3M 311	2070	
				RC 3M 321		
				RC 3M 331		
				RC 3M 341		
		1 2	↑ ↓ ↔ Up-Down	RC 3M 324		
				RC 3M 334		

Control Stations for Customer Assembly Empty Enclosure, Metal [HSN Code: 8536]

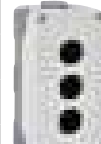



Description		Number of Ways	Reference	MRP (₹)	Product Picture
Top	Base				
Smoke Grey	Dark Grey	1	RC - 1M	1030	
		2	RC - 2M	1060	
		3	RC - 3M	1280	
		4	RC - 4M*	1560	

* Empty Enclosure's are available without contact blocks and push buttons and can be assembled with the accessories / spare parts as per specified requirements.



Operating Head for Control Stations

For Customer assembly

Plastic Operating Heads without Contact Block use with RC.P & RC.M enclosures - IP65 [HSN Code: 8536]

Description	Reference	MRP (₹)	Std. Pkg. (Nos.)	Product Picture
Flush Push Button Spring Return	RP2-BA1 ○	130	20	
	RP2-BA2 ●			
	RP2-BA3 ●			
	RP2-BA4 ●			
	RP2-BA5 ●			
	RP2-BA6 ●			
	RP2-BA334 ↑			
Projecting Push Button	RP2-BA335 Ⓢ	130	20	
	RP2-BL1 ○			
	RP2-BL2 ●			
	RP2-BL3 ●			
	RP2-BL4 ●			
	RP2-BL5 ●			
Mushroom Spring Return	RP2-BC2 ●	180	8	
	RP2-BC3 ●			
	RP2-BC4 ●			
	RP2-BC5 ●			
	RP2-BC6 ●			
Mushroom Stay Put	RP2-BS44 ●	220	10	
	RP2-BS54 ●	240	8	
	RP2-BS64 ●	390	5	

Operating Heads for Control Stations Without Contact Block and Carrier

Description	Reference	Operating Handle	MRP (₹)	Std. Pkg. (Nos.)	Product Picture	
Selector 2-Position, Stay Put	RP2-BD2	Standard	350	10		
Selector 3-Position, Stay Put (Centre OFF)	RP2-BD3	Standard				
Selector 3-Position, Spring Return (Centre OFF)	RP2-BDR3	Standard	490			
Key Selector 2-Position, Stay Put	RP2-BG2	Key removable in L.H. position	510			
Key Selector 2-Position, Stay Put	RP2-BG4	Key removable in both positions				
Key Selector 2-Position, Stay Put	RP2-BG02	Key removable in R . H. position	540			
Key Selector 3-Position, Stay Put	RP2-BG3	Key removable in centre position				
Key Selector3-Position, Stay Put	RP2-BG0	Key removable in all positions	490			
Key Selector 3-Position, Stay Put	RP2-BG5	Key removable in L. H. & R. H. position				
Key Selector 3-Position, Stay Put	RP2-BG9	Key removable in L. H. position				
Key Selector 3-Position, Stay Put	RP2-BG09	Key removable in R. H. position	490			
Key Selector 3-Position, Both Side Spring Return	RP2-BG7	Key removable in Centreposition				
Mushroom Head with Key Stay Put	RP2-BS14	Key removable in both positions	490	8		

 Non Stockable item







Operating Head for Control Stations





For Customer assembly

Global Certification   

Metallic Operating Heads without Contact Block for RC.P & RC.M enclosures - IP65 [HSN Code: 8536]

Description	Reference	MRP (₹)	Std. Pkg. (Nos.)	Product Picture
Flush Push Button Spring Return	RM2-BA1○	140	20	
	RM2-BA2●			
	RM2-BA3●			
	RM2-BA4●			
	RM2-BA5●			
	RM2-BA6●			
	RM2-BA334 †			
Projecting Push Button	RM2-BA335●	140	20	
	RM2-BL1○			
	RM2-BL2●			
	RM2-BL3●			
	RM2-BL4●			
	RM2-BL5●			
Mushroom Spring Return $\phi 40mm$	RM2-BC2●	200	8	
	RM2-BC3●			
	RM2-BC4●			
	RM2-BC5●			
	RM2-BC6●			
Mushroom Stay Put $\phi 30mm$ $\phi 40mm$ $\phi 60mm$	RM2-BS44●	250	10	
	RM2-BS54●	280	8	
	RM2-BS64●	340	5	
Mushroom Push-Pull Type $\phi 40mm$	RM2-BT43●	280	8	

Operating Heads for Control Stations Without Contact Block and Carrier [HSN Code: 8536]

Description	Reference	Operating Handle	MRP (₹)	Std. Pkg. (Nos.)	Product Picture
Selector 2-Position, Stay Put	RM2-BD2	Standard	370	10	
Selector 2-Position, Spring Return	RM2-BDR2	Standard			
Selector 3-Position, Stay Put (Centre OFF)	RM2-BD3	Standard			
Selector 3-Position, Spring Return (Centre OFF)	RM2-BDR3	Standard	490	10	
Key Selector 2-Position, Stay Put	RM2-BG2	Key removable in L.H. position			
Key Selector 2-Position, Stay Put	RM2-BG4	Key removable in both positions			
Key Selector 2-Position, Stay Put	RM2-BG02	Key removable in R. H. position			
Key Selector 2-Position, Spring Return Stay Put	RM2-BG6	Key removable in L.H. position	540	10	
Key Selector 3-Position, Stay Put	RM2-BG3	Key removable in centre position			
Key Selector 3-Position, Stay Put	RM2-BG0	Key removable in all positions	560	10	
Key Selector 3-Position, Stay Put	RM2-BG5	Key removable in L.H. & R.H. position	560		
Key Selector 3-Position, Stay Put	RM2-BG9	Key removable in L.H. position	600		
Key Selector 3-Position, Stay Put	RM2-BG09	Key removable in R. H. position			
Key Selector 3-Position, Both Side Spring Return	RM2-BG7	Key removable in Centre position	540	8	
Mushroom Head with Key Stay Put	RM2-BS14	Key removable in both positions			

Contact Blocks - Base Mounted For Control Stations Customer Assembly [HSN Code: 8536]

Description	Reference	Contact Type	MRP (₹)	Std. Pkg. (Nos.)	Product Picture
Contact Block	RB2BE-101BM/P*	NO	130	50	
Slow Break	RB2BE-102BM/P*	NC			

* Please specify 'M' if required for Metallic and 'P' if required for Plastic.

Legends (Stickers) are supplied with the following Standard Texts, Plastic [HSN Code: 8536]

Description	Reference	Standard Text	Reference	MRP (₹)	Std. Pkg. (Nos)
Start	RP2-BY2303	Stop	RP2-BY2304	25	100
Forward	RP2-BY2305	Reverse	RP2-BY2306		
		Down	RP2-BY2308		
Up	RP2-BY2307	Off	RP2-BY2312		
On	RP2-BY2311	Close	RP2-BY2314		
Open	RP2-BY2313	Hand	RP2-BY2316		
Reset	RP2-BY2323	Inch	RP2-BY2321		
Slow	RP2-BY2327	Fast	RP2-BY2328		
Power On	RP2-BY2326	Emer. Stop	RP2-BY2330		
		Left	RP2-BY2310		
Right	RP2-BY2309	--	RP2-BY2147		
O	RP2-BY2146	→	RP2-BY1912		
		←	RP2-BY1913		
		↑	RP2-BY1914		
		↑	RP2-BY1915		

Note: Minimum order of #10 each.

Legends (Stickers) are supplied with the following standard texts, Metal [HSN Code: 8536]

Description	Reference	Standard Text	Reference	MRP (₹)	Std. Pkg. (Nos)
Start	RM2-BY2303	Stop	RM2-BY2304	25	100
Forward	RM2-BY2305	Reverse	RM2-BY2306		
		Down	RM2-BY2308		
Up	RM2-BY2307	Off	RM2-BY2312		
On	RM2-BY2311	Close	RM2-BY2314		
Open	RM2-BY2313	Hand	RM2-BY2316		
Reset	RM2-BY2323	Inch	RM2-BY2321		
Slow	RM2-BY2327	Fast	RM2-BY2328		
Power On	RM2-BY2326	Emer. Stop	RM2-BY2330		
		Left	RM2-BY2310		
Right	RM2-BY2309	--	RM2-BY2147		
O	RM2-BY2146	→	RM2-BY1912		
		←	RM2-BY1913		
		↑	RM2-BY1914		
		↑	RM2-BY1915		

Note: Minimum order of #10 each.

Motor Starters

for Domestic & Agro applications



Features

- Conforms to IS 13947-4-1
- 3Ø DOL Starter range: 0.50HP~40HP
- 3Ø Reversing DOL Starter range: 0.5HP~20HP
- 3Ø Star Delta Starter range: 7.5HP~350HP

Custom built Starter solutions with incomer MCCB & Electronic Motor Protection Relay

- 3Ø Intelligent Star Delta Starter range: 40HP~ 350HP
- 3Ø Intelligent Auto Transformer Starter range: 40HP~ 350HP





Motor Starters

Conforming IS/IEC60947-4-1

Star Delta Starter with TC1DXEA Contactor & LR1D Relay in S.S. Enclosure

[HSN Code: 8536]

Std. Power Rating for 3 Ph. Motor at 415V		Reference	Relay LR1D Range Amps	MRP (₹)	MOQ
HP	kW				
3	2.2	BE3DXEAP163■307	1.6-2.5	20310	6
3	2.2	BE3DXEAP163■308	2.5-4.0	20310	
5	3.7	BE3DXEAP163■310	4.0-6.0	20310	
7.5	5.6	BE3DXEAP163■312	5.5-8.0	20310	
10	7.5	BE3DXEAP163■314	7.0-10.0	20310	
12.5	9.3	BE3DXEAP163■316	10.0-13.0	20310	
12.5	9.3	BE3DXEAP163■316X	9.0-14.0	20310	
15	11.2	BE3DXEAP203■321	13.0-18.0	22970	
20	15	BE3DXEAP253■321X	14.0-22.0	22970	
25	18.6	BE3DXEAP253■322	18.0-25.0	22970	

DOL Starter with TC1DXEA Contactor & LR1D Relay in S.S. Enclosure

[HSN Code: 8536]

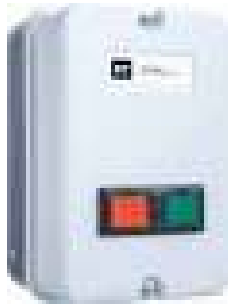

Std. Power Rating for 3 Ph. Motor at 415V		Reference	Relay LR1D Range Amps	MRP (₹)	MOQ
HP	kW				
0.5	0.37	BE1DXEAP163■305	0.63-1.0	5640	2
0.75	0.55	BE1DXEAP163■306	1.0-1.6	5640	
1.5	1.1	BE1DXEAP163■307	1.6-2.5	5640	
2	1.5	BE1DXEAP163■308	2.5-4.0	5640	
3	2.2	BE1DXEAP163■310	4.0-6.0	5640	
5	3.7	BE1DXEAP163■312	5.5-8.0	5640	
5.5	4	BE1DXEAP163■314	7.0-10.0	5640	
7.5	5.5	BE1DXEAP163■316	10.0-13.0	5640	
7.5	5.5	BE1DXEAP163■316X	9.0-14.0	5640	
12	9	BE1DXEAP203■321	13.0-18.0	6380	
12	9	BE1DXEAP253■321X	14.0-22.0	6380	
15	11	BE1DXEAP253■322	18.0-25.0	6380	
20	15	BE1DXEAP403■353	23.0-32.0	9650	
20	15	BE1DXEAP403■355	28.0-40.0	9650	

Coil voltage code for Exceed DOL & Star Delta starter

Motor Starter	Voltage		
BE1DXEAP/BE3DXEAP	220	190-400	250-450

Industrial Starters are available in the above wide band operating range Standard coil voltages.

Heavy Duty DOL Starter Type DX-P with robust 4 Pole Contactor & LR1D OLR in S.S. enclosure

[HSN Code: 8536]



Std. Power Rating for 3 Ph. Motor at 415V		Reference	Relay LR1D Range Amps	MRP (₹)	MOQ
HP	kW				
1.5	1.1	BE1-DXP204■307	1.6-2.5	POR	6
2.0	1.5	BE1-DXP204■308	2.5-4.0		
3	2.2	BE1-DXP204■310	4.0-6.0		
5	3.7	BE1-DXP204■312	5.5-8.0		
5.5	4.0	BE1-DXP204■314	7-10		
7.5	5.5	BE1-DXP204■316X	9-14		
12	9	BE1-DXP204■321	13-18		
15	11	BE1-DXP254■321XH	14-22		
		BE1-DXP254■322	18-25		
25	18	BE1-DXP404■353	23-32		



Motor Starters

Conforming IS/IEC60947-4-1

Heavy Duty Automatic Star Delta Starter Type DX-P with robust 4 Pole Contactor & LR1D OLR, Electronic Star Delta Timer in S.S. enclosure [HSN Code: 8536]



Std. Power Rating for 3 Ph. Motor at 415V		Reference	Relay LR1D Range Amps	MRP (₹)	MOQ
HP	kW				
7.5	5.5	BE3-DXP204■312	5.5~8.0	22040	2
12	9	BE3-DXP204■314	7.0~10	22040	
15	11	BE3-DXP204■316X	9~14	22040	
20	15	BE3-DXP204■321	13~18	22310	
		BE3-DXP254■321XH	14~22	25070	
25	18	BE3-DXP254■322	18~25	25070	
30	22	BE3-DXP254■353	23~32	28810	

AC Coil Voltage Codes (Standard) for Heavy Duty Industrial Starter Type DX-P

Industrial Starter	Voltage		
BE1-DXP	220	190~400#	250~450#
BE3-DXP	-	190~400#	250~450#
Coil Code	M	Q	N

Industrial Starters are available in the above wide band operating range Standard coil voltages.

DOL Starter with D range Contactor & LR1D OLR in Plastic Enclosure [HSN Code: 8536]



Std. Power Rating for 3 Ph. Motor at 415V		Reference	Relay Range Amps	MRP (₹)	MOQ
HP	kW				
0.5	0.37	LE1-D173■305	0.63~1.00	4670	1
0.75	0.55	LE1-D173■306	1.0~1.60	4670	
1.5	1.1	LE1-D173■307	1.60~2.50	4670	
2	1.5	LE1-D173■308	2.50 ~ 4.00	4670	
3	2.2	LE1-D173■310	4.00 ~ 6.00	4670	
5	3.7	LE1-D173■312	5.50 ~ 8.00	4670	
7.5	5.5	LE1-D173■316X	9.0 ~ 14.0	4670	
12	9	LE1-D253■321	13.0 ~ 18.0	9610	
15	11	LE1-D253■322	18.0 ~ 25.0	9610	

DOL Starter with D range Contactor & LR1D OLR in S.S. Enclosure [HSN Code: 8536]

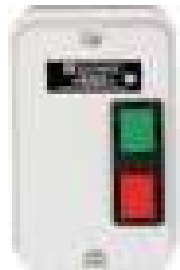

Std. Power Rating for 3 Ph. Motor at 415V		Reference	Relay Range Amps	MRP (₹)	MOQ
HP	kW				
0.5	0.37	BE1-D1735■305	0.63~1.00	5540	1
0.75	0.55	BE1-D1735■306	1.0~1.60		
1.5	1.1	BE1-D1735■307	1.60~2.50		
2	1.50	BE1-D1735■308	2.50~4.0		
3	2.2	BE1-D1735■310	4.00~6.00		
5	3.7	BE1-D1735■312	5.50~8.00		
7.5	5.5	BE1-D1735■316X	9.0~14.0		
12	9	BE1-D2535■321	13.0~18.0	11490	
15	11	BE1-D2535■322	18.0~25.0		
20	15	BE1-D3235■353	23.0~32.0	19030	
30	22	BE1-D4035■355	28.0~40.0	27870	
35	25	BE1-D5035■357	38.0~50.0	31090	
40	30	BE1-D6335■359	48.0~57.0	36210	



Motor Starters

Conforming IS/IEC60947-4-1

Reversing Starter with D range Contactor & LR1D OLR in S.S Enclosure

[HSN Code: 8536]



Std. Power Rating for 3 Ph. Motor at 415V		Reference	Relay Range Amps	MRP (₹)	MOQ
HP	KW				
0.5	0.37	BE2-D1735■305	0.63~1.00	17070	1
0.75	0.55	BE2-D1735■306	1.0~1.60		
1.5	1.1	BE2-D1735■307	1.60~2.50		
2.0	1.5	BE2-D1735■308	2.50~4.00		
3.0	2.2	BE2-D1735■310	4.00~6.00		
5.0	3.7	BE2-D1735■312	5.50~8.00		
5.5	4.0	BE2-D1735■314	7.00~10.0		
7.5	5.5	BE2-D1735■316X	9.0~14.0		
12.0	9.0	BE2-D2535■321	13.0~18.0	21120	
15.0	11.0	BE2-D2535■322	18.0~25.0	23740	
20.0	15.0	BE2-D3235■353	23.0~32.0	35000	

Automatic Star Delta Starter with D range Contactor & robusta (F Range), LR1D OLR & Electronic Star Delta Timer

[HSN Code: 8536]



Std. Power Rating for 3 Ph. Motor at 415V		Reference	Relay Range Amps	MRP (₹)	MOQ
KW	HP				
3	4	BE3-D1735■308	2.5~4.0	20280	1
4	5.5	BE3-D1735■310	4.0~6.0		
5.5	7.5	BE3-D1735■312	5.5 ~ 8.0		
9	12	BE3-D1735■314	7.0 ~ 10.0		
11	15	BE3-D1735■316X	9.0 ~ 14.0		
15	20	BE3-D2235■321	13.0 ~ 18.0	21070	
18	25	BE3-D2535■322	18.0 ~ 25.0	28550	
22	30	BE3-D3235■322	18.0 ~ 25.0	47580	
25	35	BE3-D3235■353	23.0 ~ 32.0		
30	40	BE3-D4035■355	30.0 ~ 40.0	57280	
37	50	BE3-D5035■355	30.0 ~ 40.0	76380	
51	70	BE3-D6335■359	48.0 ~ 57.0	125980	
59	80	BE3-D8035N 361	57.0 ~ 66.0		
75	100	BE3-F115 363	66.0 ~ 80.0	154850	
90	125	BE3-F115N105	65.0 ~ 105.0	184130	
110	150	BE3-F150N125	80.0 ~ 125.0	189920	
132	180	☒BE3-F185N160	100.0~160.0	303130	
160	220	☒BE3-F185N200	125.0~200.0		
200	270	☒BE3-F265N250	160.0~250.0	331540	
220	300	☒BE3-F330N315	200.0~315.0	343620	
260	350	☒BE3-F330S315	200.0~315.0		

☒ Non Stockable item

Motor Starters

Conforming IS/IEC60947-4-1

Semi-Automatic Star Delta Starter with D range Contactor, LR1D OLR

Std. Power Rating for 3 Ph. Motor at 415V		Reference	Relay Range Amps	MRP (₹)	MOQ
kW	HP				
3	4	BE3-D1735■308SA	2.5 ~ 4	14550	1
4	5.5	BE3-D1735■310SA	4 ~ 6		
5.5	7.5	BE3-D1735■312SA	5.5 ~ 8		
9	12	BE3-D1735■314SA	7 ~ 10		
11	15	BE3-D1735■316XSA	9 ~ 14	20060	
15	20	BE3-D2535■321SA	13 ~ 18		
18	25	BE3-D2535■322SA	18 ~ 25		

Coil Voltage Codes (Standard) for DOL Starters with D range Contactor

Motor Starter	Voltage	
BE1-D/LE1-D	220V	415V
Coil Code	UW	N

** DOL Motor Starter are available only in the above Standard Coil Voltages.

Coil Voltage Codes (Standard) for DOL & Star Delta Starters with D range Contactor

Motor Starter	Voltage	
BE1-D / BE2-D / BE3-D / BE3-F	380#	415
Coil Code	NW	N

Wide Band Coil available for Star Delta Starters upto 40HP only.

How to order Industrial Starter:

- Complete the code by replacing the blue square (■) by the letter(s) corresponding to the Coil Voltage selected.
- Industrial DOL Starters should be selected based on the FLC of Pump/Motor & Coil Voltage required.

Custom Built Motor Starters Solutions

■ Smart Start Delta Starter rating 40 HP to 150 HP 3 Phase 415V AC

- Incomer 3 Pole MCCB, 10-25kA
- Selection of liberal D range, air break Contactor
- Electronic motor protection relay with built-in feature having pause of 0.30 sec for motor protection against single phasing
- Electronic Star Delta Timer
- Housed in free standing IP 54 sheet steel enclosure with bottom cable entry
- Optional facility: Water Level Controller also available

■ Intelligenet Star Delta Starter rating 40 HP to 350 HP 3 Phase 415V AC

- Incomer 3 Pole MCCB, 10-25kA
- Selection of liberal D range, air break Contactor
- Digital motor protection Relay type mPro100 with 7 segment display to assure complete motor protection against overload, phase loss, under current, unbalance, motor stall, earth fault, locked rotar
- Electronic Star Delta Timer
- Housed in free standing IP 54 sheet steel enclosure with bottom cable entry

How to order Star Delta Starter:

- Complete the code by replacing the blue square (■) by the letter(s) corresponding to the Coil Voltage selected.
- Star Delta starters should be selected based on the FLC of the Pump/Motor phase current (Motor FLC X 0.58) & Coil Voltage required.

■ Intelligent Auto Transformer Starter rating 40 HP to 350 HP 3 Phase 415V AC (closed transition)

- Incomer 3 Pole MCCB, 10-25kA
- Selection of liberal D range, air break Contactor
- Digital motor protection Relay type mPro100 with 7 segment display to assure complete motor protection against overload, phase loss, under current, unbalance, motor stall, earth fault, lock rotar
- Auto Transformer, air cooled, 6 starts/hours with built-in thermister having tapping at 50%, 60% & 80% of the rated voltage
- Electronic Timer for changeover function
- Housed in free standing IP 54 sheet steel enclosure with bottom cable entry



CS1V2 Series Starters

CS1 Series Starters DOL are available with contactors 16A & 25A AC3 duty.

- CS1V2 1Phase DOL Starters range: 1HP~7.5HP
- No Qualified Technician Required to Change Kit & Coil
- One Minute Job to Change Kit & Coil
- No iron parts - all upgraded to high grade & high temperature resistance nylon for reducing the risk of rusting



3Ø DOL Starters in SS Enclosure

[HSN Code: 8536]

Reference	Relay Range (Amp)	Max. Motor Output at 415V, 3 Ph		MRP (₹)	Std. Pkg. (Nos.)
		kW	HP		
CS1V2DO■1525NR	1.5~2.5	0.75	1	3360	6
CS1V2DO■2540NR	2.5~4	1.5	2		
CS1V2DO■4065NR	4~6.5	2.2	3		
CS1V2DO■6010NR	6~10	3.7	5		
CS1V2DO■9014NR	9~14	5.5	7.5	3460	
CS1V2DO■1321NR	13~21	5.5	7.5		

Coil Voltage Codes ■

Coil Voltage (AC) 50Hz	Voltage
	230~440 N3W

CS1 Series Starters

CS1 Series Star Delta Starters are available with contactors type CS1, CS2 & CS3 having 16A, 25A, 32A AC3 duty. These Starters having following features:

- Conforms to IEC 60947-4-1
- Wide band coil
- Rugged design which is durable and easy for maintenance
- Spares are available across the country

3Ø Fully Automatic Star-Delta starters in SS Enclosure

[HSN Code: 8536]



Reference	Relay Range (Amp)	Max. Motor Output at 415V, 3Ph		MRP (₹)	Std. Pkg. (Nos.)
		kW	HP		
CS1SD■0610NR	6~10	7.5	10	11960	1
CS1SD■0914NR	9~14	9.3	12.5		
CS1SD■1118NR	11~18	11	15	12110	
CS1SD■1322NR	13~22	11	15	12210	
CS2SD■1322NR	13~22	11	15	12390	
CS2SD■2032NR	20~32	11	15	12600	
CS3SD■2032NR	20~32	16	22	12910	

3Ø DOL in S.S. Enclosure

[HSN Code: 8536]

Incorporating Heavy Duty 4 Pole Contactor type TC1-DX with wide band operating coil, Overload relay type LR3D with manual re-set and yellow flag for trip indication



Reference	Relay Range (Amp)	Standard Power Rating		MRP (₹)	Std. Pkg. (Nos.)
		kW	HP		
BE1-DXM204■307NR	1.6~2.5	0.75	1	5070	6
BE1-DXM204■308NR	2.5~4	1.1/1.5	1.5/2		
BE1-DXM204■310NR	4~6	2.2	3		
BE1-DXM204■312NR	5.5~8	2.2	3		
BE1-DXM204■314NR	7~10	3.7	5		
BE1-DXM204■316XNR	9~14	3.7/4	5/5.5		
BE1-DXM204■321NR	13~18	5.5	7.5	5420	
BE1-DXM254■321XNR	14~22	7.5	10	5690	
BE1-DXM254■322NR	18~25	10	12	5890	
BE1-DXM404■353NR	23~32	11	15	8120	

Motor Starters

Conforming IS/IEC60947-4-1

3Ø Automatic Star Delta Starter in S.S Enclosure

[HSN Code: 8536]

Incorporating Heavy Duty 4 Pole Contactor type TC1-DX with wide band operating coil, Overload relay type LR3D for motor protection & Electronic Star Delta Timer



Reference	Relay Range (Amp)	Std. Power Rating for 3P at 415V		MRP (₹)	Std. Pkg. (Nos.)
		kW	HP		
BE3-DXM204■308NR	2.5-4	1.5	2	16560	2
BE3-DXM204■310NR	4-6	2.2	3		
BE3-DXM204■312NR	5.5-8	3.7	5		
BE3-DXM204■314NR	7-10	5.5	7.5		
BE3-DXM204■316XNR	9-14	9	12		
BE3-DXM204■321NR	13-18	11	15	17070	
BE3-DXM254■321XNR	14-22	11	15	19540	
BE3-DXM254■322NR	18-25	11	15		
BE3-DXM254■353NR	23-32	15/18	20/25	20690	

3Ø Semi Automatic Star Delta Starter in S.S Enclosure

[HSN Code: 8536]

Incorporating Heavy Duty 4 Pole Contactor type TC1-DX with wide band operating coil, Overload relay type LR3D for motor protection



Reference	Relay Range (Amp)	Std. Power Rating for 3P at 415V		MRP (₹)	Std. Pkg. (Nos.)
		kW	HP		
BE3-DXM204■314SANR	7-10	9	12	13760	2
BE3-DXM204■316XSANR	9-14	11	15		
BE3-DXM204■321SANR	13-18	15	20		
BE3-DXM254■321XSANR	14-22	18	25	17610	
BE3-DXM254■322SANR	18-25	18	25		
BE3-DXM254■353SANR	23-32	22.5	30	19330	

3Ø Submersible Pump Starter Automatic Star Delta in S.S. Enclosure

[HSN Code: 8536]

Incorporating Heavy Duty 4 Pole contactor type TC1-DX with wide band operating coil, Overload relay type LR1D with pneumatic timer



Reference	Relay (Amp)	Standard Power Rating		MRP (₹)	Std. Pkg. (Nos.)
		kW	HP		
BE3-DXM204■307-PTNR	1.6-2.5	1.5	2	16630	1
BE3-DXM204■308-PTNR	2.5-4	3	4		
BE3-DXM204■310-PTNR	4-6	4	5.5		
BE3-DXM204■312-PTNR	5.5-8	5.5	7.5		
BE3-DXM204■316X-PTNR	9-14	11	15		
BE3-DXM204■321-PTNR	13-18	15	20	17160	
BE3-DXM254■321X-PTNR	14-22	18	25	19690	
BE3-DXM254■322 -PTNR	18-25	18	25		
BE3-DXM254■353 -PTNR	23-32	22.5	30	20820	

Coil Voltage Codes (Standard) for DOL / Star Delta Starters

Coil Voltage (AC) 50Hz	Voltage	
	190-400 Q	250-440 N

Protection Measurement & Control Devices



- Surge Protection Device
- Digital Panel Meters
- Multi Function Meters
- Power Factor Controller
- Power Quality Measurements
- Demand Controller
- Electronic Motor Protection Relay
- Electronic Motor Protection Relay-CSMP
- Earth Leakage Relay
- DG AMF / Synchronizing Controller
- Voltage & Current Monitoring Relay & Timer
- Temperature Sensor

Engineered to Deflect
Designed to Protect



Features

- Available in both AC & DC
- Pole: 1P+N, 2P, 3P, 3P+N
- Degree of protection IP20
- DIN Rail Mounted
- With Remote signal contact
- Pluggable Module for Easy Replacement

Reference	HSN Code	Type	Voltage (Uc)	I _{max}	Pole	MRP (₹)	Std. Pkg. (Nos)	
CSPDT2385AC1PN	8536	Type2	AC	385V	40kA	1P+N	2230	2
CSPDT2385AC3PN	8536			385V	40kA	3P+N	2920	1
CSPDT2600DC2P	8536	Type2	DC	600V	40kA	2P	2230	2
CSPDT21000DC3P	8536			1000V	40kA	3P	2920	1
CSPDT21500DC3P	8536			1500V	40kA	3P	3940	1
CSPDT120385AC1PN	8536	Type 1+2	AC	385V	50kA	1P+N	7600	2
CSPDT120385AC3PN	8536			385V	50kA	3P+N	13810	1
CSPDT120800AC3PN	8536			880V	10kA	3P+N	14000	2
CSPDT121300AC3PN	8536			1300V	10kA	3P+N	15100	2
CSPDT12900125DC3P	8536	Type 1+2	DC	900V	50kA	3P	7920	2
CSPDT1215005DC3P	8536			1500V	50kA	3P	8406	2
CSPDT121500125DC3P	8536			1500V	50kA	3P	20720	1



METERING SOLUTIONS



Basic Meter



DC Energy Meter



Energy Meter

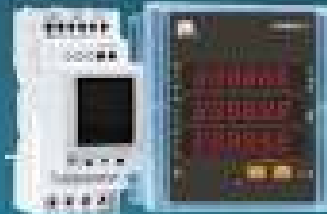

Multifunction Meter



Power Quality Analyser

Features

- High & Low measurement of voltage & current
- Alpha numeric display
- Single row LCD/3 Row customized LED
- Dynamic communication*
- Direct metering
- Complete range from Basic Meter to Power Analyser

Branch Circuit Power monitor

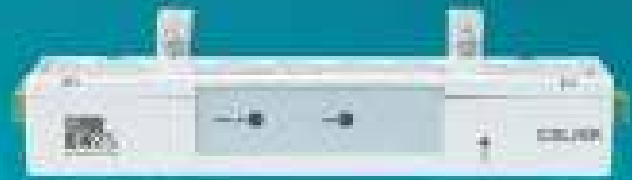

BASIC METERS

Reference	Description	HSN Code	MRP (₹)
CSM1V1	Single Phase Voltmeter, Class 1.0, AUX 80-300V AC/DC	9030	1440
CSM1A1	Single Phase Ammeter, Class 1.0, 5A,AUX 80-300V AC/DC	9030	1440
CSM3V1	Three Phase Voltmeter, Class 1.0, AUX 80-300V AC/DC	9030	2170
CSM3A1	Three Phase Ammeter, Class 1.0, AUX 80-300V AC/DC	9030	2390
CSM1V0.5	Single Phase Voltmeter, Class 0.5 AUX 80-300V AC/DC	9030	1850
CSM1A0.5	Single Phase Ammeter,Class 0.5, AUX 80-300V AC/DC	9030	1850
CSMFM0.2	Frequency Meter, Class 0.2, AUX 80-300V AC/DC	9030	1930
CSM3V0.5	Three Phase Voltmeter,Class 0.5,AUX 80-300V AC/DC	9030	2390
CSM3A0.5	Three Phase Ammeter, Class 0.5, AUX 80-300V AC/DC	9030	2400
CSM3VAF1	VAF Meter, Class 1.0, 5A Inbuilt (3 Rows), AUX 80-300V AC/DC	9030	2800
CSM3VAF0.5	VAF Meter, Class 0.5, 5A Inbuilt (3 Rows), AUX 80-300V AC/DC	9030	3080

DC ENERGY METER

Reference	Description	HSN Code	MRP (₹)
CSMDCE1D1	Class1.0,Single Channel DC Energy Meter	9030	POR
CSMDCE1D4	Class1.0,Four Channel DC Energy Meter	9030	POR

ENERGY METER

Reference	Description	HSN Code	MRP (₹)
CSMEM1	Energy Meter,Class 1.0,User selectable any one parameters from VAF or Kw or PF or KVA or Kwh (Single Row LED)	9030	3870
CSMEM1-C	Energy Meter,Class 1.0,RS485, User selectable any one parameters from VAF or Kw or PF or KVA or Kwh (Single Row LED)	9030	4800
CSMEM0.5	Energy Meter,Class 0.5, User selectable any one parameters from VAF or Kw or PF or KVA or Kwh (Single Row LED)	9030	4760
CSMEM0.5-C	Energy Meter,Class 0.5,RS485, User selectable any one parameters from VAF or Kw or PF or KVA or Kwh (Single Row LED)	9030	5360
CSKWH1CT	Energy Meter,Class 1.0, 5A Inbuilt, Counter type	9030	5000

MULTIFUNCTION METER

Reference	Description	HSN Code	MRP (₹)
CSMFM1-C	MFM,Class 1.0,RS485, AVF, PF, KW, KVA , KWh / KVAh (Any one),Load Hours, ON Hours, OLD Energy - 3Rows LED	9030	8230
CSMFM0.5-C	MFM,Class 0.5,RS485, AVF, PF, KW, KVA , KWh / KVAh (Any one)Load Hours, ON Hours, OLD Energy- 3Rows LED	9030	8660
CSMMFM15D-C	MFM, Class 1.0, RS 485 , AVF, PF, KW, KVA, KWh, KVAh, Load Hours, ON Hours, 100A Direct 5 Module DIN Mount Single row LCD	9030	9240
CSMMFM1D-C	MFM, Class 1.0 , RS 485, Single Phase , AVF, PF, KW, KVA, KWh, KVAh, Load Hours,ON Hours, CO2, 2 Module DIN Mount), 100A Direct measurement	9030	5820
CSMMFM1LM-C	MFM, Class 1.0,RS485, AVF, PF, KW, KVA, KWh, KVAh, KVRh, Import energy, - 4 Rows LEDLoad Hours, ON Hours, No of Interrupts, THD V&A, Hi-Low recordings	9030	11950
CSMMFM0.5LM-C	MFM, Class 0.5,RS485, AVF, PF, KW, KVA, KWh, KVAh, KVRh, Import energy, - 4 Rows LED,Load Hours, ON Hours, No of Interrupts, THD V&A,Hi-Low recordings	9030	13700
CSMMFM1DMC-C	MFM, Class 1.0,RS485, AVF, PF, KW, KVA, KWh, KVAh, KVRh, Import energy, - 4 Rows LED,Load Hours, ON Hours, no of Interrupts, THD V&A, Hi-Low recordings, 4 relay demand controller with TOD	9030	34520
CSMMFM0.5DMC-C	MFM, Class 0.5s,RS485, AVF, PF, KW, KVA, KWh, KVAh, KVRh, Import energy, - 4 Rows LED,Load Hours, ON Hours, no of Interrupts, THD V&A, Hi-Low recordings, 4relay demand controller with TOD	9030	40240

POWER MONITOR

Reference	Description	HSN Code	MRP (₹)
CSMFMPN0.5S-C	PQ parameters, Class 0.5S RS485, AVF, PF, KW, KVA, KWh, KVAh, KVRh,Import and Export energy, Total and Net Energy, Load Hours, ON Hours, CO2, Power Cycle,THD, K factor, Crest Factor, TEHD, TOHD, Voltage with IH upto 63rd, RTC, 8 TOD, High Low Instantaneous, Sag, Swell,and Current Squared Hours, Demand Monitor2DI+2DO, 256MB Data Logging, Ethernet Port - 4 Rows LCD	9030	POR

POWER QUALITY ANALYSER

Reference	Description	HSN Code	MRP (₹)
CSMFMPQ0.2S-C	Power Quality Analysers, Class 0.2S, RS485, AVF, PF, KW, KVA, KWh, KVAh, KVRh, Import and Export energy, Total and Net Energy, Load Hours, ON Hours, CO2, Power Cycle, THD, K factor,Crest Factor, TEHD, TOHD, Voltage and Current Squared Hours, Demand Monitor with IH upto63rd, RTC, 8 TOD, High Low Instantaneous, Sag, Swell, TDD, 2DI+2DO,2GB Data Logging, Ethernet Port - 3.5" TFT	9030	POR

BRANCH CIRCUIT POWER MONITOR

Reference	Description	HSN Code	MRP (₹)
CSlink32A	ET5030D11500 - different variants -32A	9030	54170
CSlink50A	ET5030D11500 - different variants -50A	9030	58330



MITIGATE YOUR POWER QUALITY ISSUES

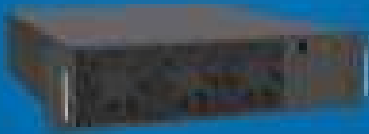

APF

- Reduce Network losses
- Reduce energy
- Reduce Hazardous & failure

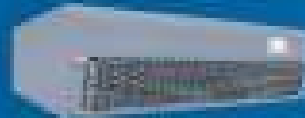

AVG

- Improved Power Factor
- Enhanced capacity utilization
- Optimised voltage stability



Reactor

- Eliminates Harmonic Amplification
- Reduce overheating of Transformer
- Prolonged power factor capacity

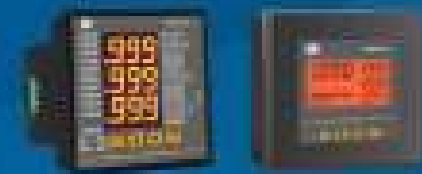

APFCR

- Provides fast & precise switching
- Available for both contactor & thyristor switching
- RS485 Module RTU Protocol

TSM

- Save operational cost.
- High accuracy
- Eliminates inrush current.



Power Factor controller for Capacitor Switching

Single CT-Sensing

Features

- 6/8/12 Conventional (Contactor switching) Power Factor Controller
- Protection & Indication of abnormal condition such as over/under compensation, over Voltage, over/under Current etc.
- Wide range of CT ratio & Target PF Selection
- Automatic C/K Setup Mode.
- Indication of Active bank through LED's
- Selection of various wiring scheme



Description	Reference	HSN Code	MRP (₹)
Single CT Input Controller (LED based)			
6 Stage APFC Controller with Single CT Input	CSPF-100-R06-110	85381010	13690
8 Stage APFC Controller with Single CT Input	CSPF-100-R08-110	85381010	16210
12 Stage APFC Controller with Single CT Input	CSPF-100-R12-110	85381010	18510
Single CT Input Controller (LCD based)			
6 Stage APFC Controller with Single CT Input	CSPF-200-R06-220	85381010	18250
8 Stage APFC Controller with Single CT Input	CSPF-200-R08-220	85381010	20000
12 Stage APFC Controller with Single CT Input	CSPF-200-R12-220	85381010	21880

Three CT-Sensing

Features

- Configurable Alarm Settings for Voltage / Current / THD
- Auto CT Polarity detection.
- Auto Aging Detection & Correction of Capacitor Value.
- 6, 8 & 12 steps.
- Under compensation alarm (optional).
- User selection of Auto / Manual / Off individual of Capacitor mode.
- ModBus - RTU communication



Reference	Description	Steps	HSN Code	MRP (₹)	Std. Pkg. (Nos.)
CS3PFC-96-R6	Controller for Capacitor switching with 3P-3CT	6	8538	21140	1
CS3PFC-96-R8		8	8538	23180	
CS3PFC-96-R12		12	8538	31820	
CS3PFC-96-R6-C	Controller for Capacitor switching with 3P-3CT, RS485, Alarm contact	6	8538	21840	1
CS3PFC-96-R8-C		8	8538	23880	
CS3PFC96-R12-C		12	8538	34550	



Protection, Measurement & Control Devices

Power Factor Controller For Capacitor & Shunt Reactor Switching



Features

- APFC Relay
- CT Sensing
- Built in MFM with PF controller LCD display
- Leading PF compensation using shunt reactor
- CT Polarity Auto Correction % THD upto 31st harmonics
- Alarms: Under / Over compensation, High voltage, THD-I, THD-V,
- FAN Output (optional)
- Sizes upto 8,12,16 Relay
- RS 485 Modbus RTU Protocol
- Available for both contactor and thyristor switching

Reference	Description	Steps	HSN Code	MRP (₹)	Std. Pkg. (Nos.)
CS3PFCR-144-R8	Controller for Capacitor & Shunt Reactor switching with 3P-3CT	8	8538	28820	1
CS3PFCR-144-R12		12	8538	34410	
CS3PFCR-144-R16		16	8538	34120	
CS3PFCR-144-R8-C	Controller for Capacitor & Shunt Reactor switching with 3P-3CT , RS485, Alarm	8	8538	32350	1
CS3PFCR-144-R12-C		12	8538	38240	
CS3PFCR-144-R16-C		16	8538	48240	

DETUNED REACTOR (HD REACTOR, 7% IPOO)



kVAR rating	Reference (Aluminium)	MRP (₹)	Reference (Copper)	MRP (₹)	HSN Code	Std. Pkg. (Nos.)
5KVAR	CSR7AL5	POR	CSR7CU5	POR	8504	1
10KVAR	CSR7AL10		CSR7CU10		8504	
12.5KVAR	CSR7AL12.5		CSR7CU12.5		8504	
15KVAR	CSR7AL15		CSR7CU15		8504	
20KVAR	CSR7AL20		CSR7CU20		8504	
25KVAR	CSR7AL25		CSR7CU25		8504	
30KVAR	CSR7AL30		CSR7CU50		8504	
50KVAR	CSR7AL50		CSR7CU100		8504	
100KVAR	CSR7AL100		-		8504	

THYRISTOR SWITCHING MODULE

KVAR rating	Reference	PIV	Triggering	Voltage	MRP (₹)	HSN Code	Std. Pkg. (Nos.)
5KVAr	CSTM1805	1800	12-24V DC	12-24V DC	POR	8504	1
10KVAr	CSTM1810	1800	12-24V DC	12-24V DC		8504	
15KVAr	CSTM1815	1800	12-24V DC	12-24V DC		8504	
25KVAr	CSTM1825	1800	12-24V DC	12-24V DC		8504	
50KVAr	CSTM1850	1800	12-24V DC	12-24V DC		8504	
75KVAr	CSTM1875	1800	12-24V DC	12-24V DC		8504	
100KVAr	CSTM18100	1800	12-24V DC	12-24V DC		8504	
5KVAr	CSTM2205	2200	12-24V DC	12-24V DC	POR	8504	1
10KVAr	CSTM2210	2200	12-24V DC	12-24V DC		8504	
15KVAr	CSTM2215	2200	12-24V DC	12-24V DC		8504	
25KVAr	CSTM2225	2200	12-24V DC	12-24V DC		8504	
50KVAr	CSTM2250	2200	12-24V DC	12-24V DC		8504	
75KVAr	CSTM2275	2200	12-24V DC	12-24V DC		8504	
100KVAr	CSTM22100	2200	12-24V DC	12-24V DC		8504	

AVG
Features

- Range up to 100kVAr (10kVAr /30kVAr /50kVAr/75kVAr/ 100kVAr)
- Harmonic capacity is restricted to 50% of the overall capacity
- Leading and Lagging reactive power compensation
- Modular solution for future expansion

AVG Rating	Reference	MRP (₹)	HSN Code	Std. Pkg. (Nos.)
10KVAr 3P/4W AVG, IP20	CSAVG10	POR	8504	1
30KVAr 3P/4W AVG, IP20	CSAVG30		8504	
50KVAr 3P/4W AVG, IP20	CSAVG50		8504	
75KVAr 3P/4W AVG, IP20	CSAVG75		8504	
100KVAr 3P/4W AVG, IP20	CSAVG100		8504	
150KVAr 3P/4W AVG, IP20	CSAVG150		8504	

APF
Features

- Stepless Reactive Power Compensation
- Response Time <10ms
- Improved power factor upto unity
- Compliance with Harmonic Regulations

APF Rating	Reference	MRP (₹)	HSN Code	Std. Pkg. (Nos.)
15A 3P/4W APF, IP20	CSAPF15A	POR	8504	1
50A 3P/4W APF, IP20	CSAPF50A		8504	
75A 3P/4W APF, IP20	CSAPF75A		8504	
100A 3P/4W APF, IP20	CSAPF100A		8504	
150A 3P/4W APF, IP20	CSAPF150A		8504	
200A 3P/4W APF, IP20	CSAPF200A		8504	
HMI- 7" Coloured Touch screen HMI	CSAVGHMI7	POR	8504	1

EOR ELECTRONIC OVERLOAD RELAY

'Solution for Precise Protection'

Upgraded Defence

- Protections Offered: Thermal Overload, Phase Unbalance*, Phase Loss*, Under Load / Dry Run, Phase Reverse*, Locked Rotor.

Diversified Selection

- Selectable Trip Class, Nominal Current, Under Load, Auto / Manual Reset Mode.
- 3Ø & 1Ø Models.

Superior Design

- Operational at High Temperature with low power consumption
- Built in CTs & Compatibility with various types of Loads

Revamped Safety

- Individual Fault LED helps quick fault annunciation
- Lockout Mode ensures absolute safety

*For MRP & other details please contact to nearest Branch Office.

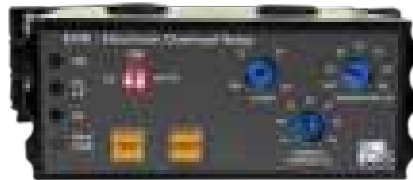

CSPMC 4.0

- Integrated metering, protection, control and communication
- Voltage & Current based protection
- Unique Modular Design on 35mm DIN Rail mounting
- Display module for local monitoring and configuration
- Detailed operating, service and diagnostic data
- Remote monitoring and control over communication
- Different Start control mode Aux Supply: 90-264V AC/DC
- Pluggable terminals easy to install and maintenance
- Overall dimension - Display module (HxWxD): 70x100x38mm
- Main module (HxWxD): 112x67.5x78mm

*For MRP & other details please contact to nearest Branch Office.



ARCPRO V_1

ARC Protection Relay

Arc Protection Solution

- High speed arc fault detection with a state of the art of electronics in association with special optical fibres and sensors.
- High Speed Arc detection time (<2msec)
- Four Point sensor inputs
- One Line sensor input
- Five Zones configuration with sensor input and DO output
- ARC detection and recording with date and time stamp
- Compact and slim in size
- Continuous Arc sensor health supervision & Alarm output
- Self-supervision with alarm Contact
- Fault record with Date & Time stamp
- Wide range Aux supply suitable for AC/DC
- Interactive HMI with USB Plug & Play Support

*For MRP & other details please contact to nearest Branch Office.





Electronic Motor Protection Relay

Models

mPRO200, mPRO100, mPRO90, mPRO 50

Protection

Overload/Phase loss/Locked rotor/Stall/Phase reversal/Current unbalance/Short circuit/ Under current/Earth fault (Residual/CBCT) Over temperature, external fault

Features

- Din mount Base & Door mount LCD Display
- High Accurate Compact Multi Protection LV Protection Relay
- Trip Class Selection from 5 to 60
- Can be use in Inverter Circuit (20-200Hz)
- Last 5 fault records / Motor Run hour
- Option Modbus on RS485 or 4-20 mA analog output
- Last 3 START / STOP record
- DI / DO Matrix programmability
- Multiple Reset functions



mPRO200

Description	Reference	Current Range (A)	HSN Code	MRP (₹)
MPRO-200, Rated current range (5-60A), with internal residual calculation, Aux supply (190-260V AC)	MPRO-200-60-E-00-H-V2	5.0-60	85364900	21080
MPRO-200, Rated current range (1-5A), with internal residual calculation, Aux supply (190-260V AC)	MPRO-200-05-E-00-H-V2	1.0-5.0	85364900	21080
MPRO-200, Rated current range (5-60A), with internal residual calculation, Aux supply (100-160V AC)	MPRO-200-60-E-00-L-V2	5.0-60	85364900	21080
MPRO-200, Rated current range (1-5A), with internal residual calculation, Aux supply (100-160V AC)	MPRO-200-05-E-00-L-V2	1.0-5.0	85364900	21080
MPRO-200, Rated current range (1-5A), with internal residual calculation, 4-20mA output + DI, Aux supply (190-260V AC)	MPRO-200-05-E-A0-H-V2	1.0-5.0	85364900	26350
MPRO-200, Rated current range (1-5A), with internal residual calculation, 4-20mA output + DI, Aux supply (100-160V AC)	MPRO-200-05-E-A0-L-V2	1.0-5.0	85364900	26350
MPRO-200, Rated current range (1-5A), with internal residual calculation, MODBUS RS485+DI, Aux supply (190-260V AC)	MPRO-200-05-E-C0-H-V2	1.0-5.0	85364900	26350
MPRO-200, Rated current range (1-5A), with internal residual calculation, MODBUS RS485+DI, Aux supply (100-160V AC)	MPRO-200-05-E-C0-L-V2	1.0-5.0	85364900	26350
MPRO-200, Rated current range (1-5A), with external CBCT Circular ID=57mm, Plastic casing, Aux Supply (190-260V AC)	MPRO-200-05-Z55-00-H-V2	1.0-5.0	85364900	27670
MPRO-200, Rated current range (1-5A), with external CBCT Circular ID=57mm, Plastic casing, Aux Supply (100-160V AC)	MPRO-200-05-Z55-00-L-V2	1.0-5.0	85364900	27670
MPRO-200, Rated current range (1-5A), with external CBCT Circular ID=57mm, Plastic casing, 4-20mA output + DI, Aux Supply (190-260V AC)	MPRO-200-05-Z55-A0-L-C1-V2	1.0-5.0	85364900	52690
MPRO-200, Rated current range (1-5A), with external CBCT Circular ID=57mm, Plastic casing, 4-20mA output + DI, Aux Supply (100-160V AC)	MPRO-200-05-Z55-A0-L-V2	1.0-5.0	85364900	38210
MPRO-200, Rated current range (1-5A), with external CBCT Circular ID=57mm, Plastic casing, 4-20mA output + DI, Aux Supply (190-260V AC)	MPRO-200-05-Z55-A0-H-V2	1.0-5.0	85364900	38210
MPRO-200, Rated current range (1-5A), with external CBCT Circular ID=57mm, Plastic casing, MODBUS RS485 + DI, Aux Supply (100-160V AC)	MPRO-200-05-Z55-C0-L-V2	1.0-5.0	85364900	38210
MPRO-200, Rated current range (5-60A), with internal residual calculation, 4-20mA output + DI, Aux supply (100-160V AC)	MPRO-200-60-E-A0-L-V2	5.0-60	85364900	26350
MPRO-200, Rated current range (5-60A), with internal residual calculation, 4-20mA output + DI, Aux supply (190-260V AC)	MPRO-200-60-E-A0-H-V2	5.0-60	85364900	26350
MPRO-200, Rated current range (5-60A), with internal residual calculation or external CBCT (field selectable), Aux Supply (85-300V AC/DC)	MPRO-200-60-EZ-00-W-V2	5.0-60	85364900	52690
MPRO-200, Rated current range (5-60A), with internal residual calculation or external CBCT (field selectable), MODBUS RS485, Aux Supply (85-300V AC/DC)	MPRO-200-60-EZ-R0-W-V2	5.0-60	85364900	52690
MPRO-200, Rated current range (5-60A), with internal residual calculation, MODBUS RS485 + DI, Aux supply (190-260V AC)	MPRO-200-60-E-C0-H-V2	5.0-60	85364900	26350
MPRO-200, Rated current range (5-60A), with external CBCT Circular ID=57mm, Plastic casing, 4-20mA output + DI, Aux supply (100-160V AC)	MPRO-200-60-Z55-A0-L-C1-V2	5.0-60	85364900	52690
MPRO-200, Rated current range (5-60A), with external CBCT Circular ID=57mm Plastic casing, 4-20mA + DI, Aux supply (100-160V AC)	MPRO-200-60-Z55-A0-L-V2	5.0-60	85364900	38210
MPRO-200, Rated current range (5-60A), with external CBCT Circular ID=57mm Plastic casing, 4-20mA + DI, Aux supply (190-260V AC)	MPRO-200-60-Z55-A0-H-V2	5.0-60	85364900	38210
MPRO-200, Rated current range (5-60A), with external CBCT Circular ID=57mm Plastic casing, Aux supply (190-260V AC)	MPRO-200-60-Z55-00-H-V2	5.0-60	85364900	27670
MPRO-200, Rated current range (5-60A), with external CBCT Circular ID=57mm Plastic casing, Aux supply (100-160V AC)	MPRO-200-60-Z55-00-L-V2	5.0-60	85364900	27670
MPRO-200, Rated current range (1-5A), with external CBCT Circular ID=92mm, Plastic casing, Aux Supply (190-260V AC)	MPRO-200-05-Z90-00-H-V2	1.0-5.0	85364900	33600
MPRO-200, Rated current range (1-5A), with external CBCT Circular ID=57mm Plastic casing, MODBUS RS485 + DI, Aux Supply (190-260V AC)	MPRO-200-05-Z55-C0-H-V2	1.0-5.0	85364900	38210



Protection, Measurement & Control Devices



mPRO100



mPRO90

Description	Reference	Current Range (A)	HSN Code	MRP (₹)
MPRO-100, Rated current range (1-5A), with internal residual calculation, Aux Supply (190-260V AC)	MPRO-100-5-E-H-V2	1.0-5.0	85364900	19100
MPRO-100, Rated current range (1-5A), with internal residual calculation, Aux Supply (100-160V AC)	MPRO-100-5-E-L-V2	1.0-5.0	85364900	19100
MPRO-100, Rated current range (5-60A), with internal residual calculation, Aux Supply (190-260V AC)	MPRO-100-60-E-H-V2	5.0-60	85364900	19100
MPRO-100, Rated current range (5-60A), with internal residual calculation, Aux Supply (100-160V AC)	MPRO-100-60-E-L-V2	5.0-60	85364900	19100
MPRO-100, Rated current range (1-5A), with external CBCT circular, ID=57mm, plastic casing, Aux Supply (100-160V AC)	MPRO-100-5-Z55-L-V2	1.0-5.0	85364900	26350
MPRO-100, Rated current range (1-5A), with external CBCT circular, ID=70mm, plastic casing, Aux Supply (100-160V AC)	MPRO-100-5-Z70-L-V2	1.0-5.0	85364900	32280
MPRO-100, Rated current range (1-5A), with external CBCT circular, ID=92mm, plastic casing, Aux Supply (100-160V AC)	MPRO-100-5-Z90-L-V2	1.0-5.0	85364900	32280
MPRO-100, Rated current range (1-5A), with external CBCT circular, ID=120mm, plastic casing, Aux Supply (100-160V AC)	MPRO-100-5-Z120-L-V2	1.0-5.0	85364900	30300
MPRO-100, Rated current range (5-60A), with external CBCT circular, ID=57mm, plastic casing, Aux supply (100-160V AC)	MPRO-100-60-Z55-L-V2	5.0-60	85364900	26350
MPRO-100, Rated current range (5-60A), with external CBCT circular, ID=70mm, plastic casing, Aux supply (100-160V AC)	MPRO-100-60-Z70-L-V2	5.0-60	85364900	27670
MPRO-100, Rated current range (5-60A), with external CBCT circular, ID=92mm, plastic casing, Aux supply (100-160V AC)	MPRO-100-60-Z90-L-V2	5.0-60	85364900	28980
MPRO-100, Rated current range (5-60A), with external CBCT circular, ID=120mm, plastic casing, Aux supply (100-160V AC)	MPRO-100-60-Z120-L-V2	5.0-60	85364900	30300
MPRO-100, Rated current range (1-5A), with external CBCT circular, ID=57mm, plastic casing, Aux Supply (190-260V AC)	MPRO-100-5-Z55-H-V2	1.0-5.0	85364900	26350
MPRO-100, Rated current range (1-5A), with external CBCT Circular ID=70mm, Plastic casing, Aux Supply (190-260V AC)	MPRO-100-5-Z70-H-V2	1.0-5.0	85364900	27670
MPRO-100, Rated current range (1-5A), with external CBCT circular, ID=92 mm, plastic casing, Aux Supply (190-260V AC)	MPRO-100-5-Z90-H-V2	1.0-5.0	85364900	28980
MPRO-100, Rated current range (1-5A), with external CBCT Circular ID=120mm, Plastic casing, Aux Supply (190-260V AC)	MPRO-100-5-Z120-H-V2	1.0-5.0	85364900	30300
MPRO-90, External CT1 Rated current Range (0.2-10A), with internal residual calculation	MPRO-90-CT1-E	0.2-10	85364900	11590
MPRO-90, External CT2 Rated current Range (0.8-25A), with internal residual calculation	MPRO-90-CT2-E	0.8-25	85364900	11590
MPRO-90, External CT3 Rated current Range (2-62.5A), with internal residual calculation	MPRO-90-CT3-E	2.0-62.5	85364900	12260
MPRO-90, External CT4 Rated current Range (4-125A), with internal residual calculation	MPRO-90-CT4-E	4.0-125	85364900	14500
MPRO-90, External CT5 Rated current Range (8-250A), with internal residual calculation	MPRO-90-CT5-E	8.0-250	85364900	18450
MPRO-90, External CT1 Rated current Range (0.2-10A), with internal residual calculation, Star-Delta	MPRO-90-CT1-E-SDT	0.2-10	85364900	24380
MPRO-90, External CT2 Rated current Range (0.8-25A), with internal residual calculation, Star-Delta	MPRO-90-CT2-E-SDT	0.8-25	85364900	24380
MPRO-90, External CT3 Rated current Range (2-62.5A), with internal residual calculation, Star-Delta	MPRO-90-CT3-E-SDT	2.0-62.5	85364900	25030
MPRO-90, External CT4 Rated current Range (4-125A), with internal residual calculation, star-Delta	MPRO-90-CT4-E-SDT	4.0-125	85364900	27670
MPRO-90, External CT5 Rated current Range (8-250A), with internal residual calculation, Star-Delta	MPRO-90-CT5-E-SDT	8.0-250	85364900	31630



Protection, Measurement & Control Devices



ACCESSORIES

Description	Reference	HSN Code	MRP (₹)
Current Transformer Ratio 100/5A, Burden 5VA, Cl.1.0	3-CT-100/5	85043100	5450
Current Transformer Ratio 200/5A, Burden 5VA, Cl.1.0	3-CT-200/5	85043100	5450
Current Transformer Ratio 300/5A, Burden 5VA, Cl.1.0	3-CT-300/5	85043100	6790
Current Transformer Ratio 400/5A, Burden 5VA, Cl.1.0	3-CT-400/5	85043100	6790
Current Transformer Ratio 500/5A, Burden 5VA, Cl.1.0	3-CT-500/5	85043100	9620
Current Transformer Ratio 600/5A, Burden 5VA, Cl.1.0	3-CT-600/5	85043100	9620

ORDERING INFORMATION

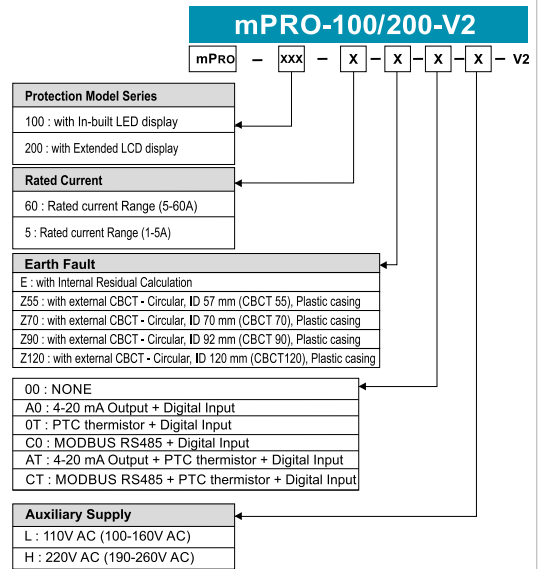
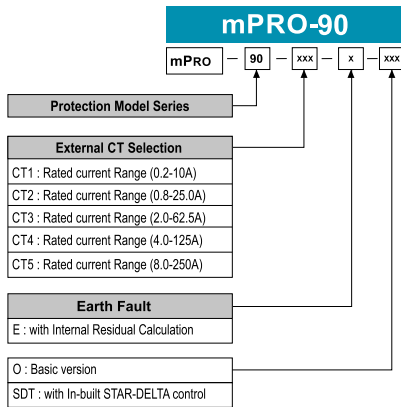

* CBCT Ordering Information (To be selected for mPRO-200-x-Z-x-x model)

CBCT SIZE
Z55 : Circular, ID 57 mm (CBCT 55), Plastic casing
Z70 : Circular, ID 70 mm (CBCT 70), Plastic casing
Z90 : Circular, ID 92 mm (CBCT 90), Plastic casing
Z120 : Circular, ID 120 mm (CBCT 120), Plastic casing



Protection, Measurement & Control Devices

Electronic Motor Protection Relay - CSMP

Protection

Overload/Phase loss/Locked rotor/Phase reversal/Current unbalance/Short circuit/Under current/ Earth fault

Features

- Detachable Din mount Base & Door mount LED Display
- High Accurate Compact Multi Protection LV Protection Relay
- Trip Class Selection from 5 to 60
- Display of 3 phase RMS Current, % current unbalance
- Looping option is available for FHP motors
- Fault diagnostic by LED indication



Description	Reference	Current Range (A)	HSN Code	MRP (₹)
Relay CSMPA-80-3SR,80A,100-260VAC	CSMPA-80-3SR,80A,100-260VAC	16-80	85364900	POR
Relay CSMPA-40-3SR,40A,100-260VAC	CSMPA-40-3SR,40A,100-260VAC	8.0-40	85364900	
Relay CSMPA-40-3SR,20A,100-260VAC	CSMPA-40-3SR,20A,100-260VAC	4.0-20	85364900	
Relay CSMPA-22-3SR,22A,100-260VAC	CSMPA-22-3SR,22A,100-260VAC	4.4-22	85364900	
Relay CSMPA-22-3SR,5A,100-260VAC	CSMPA-22-3SR,5A,100-260VAC	1.0-5	85364900	
Relay CSMPA-22-3SR,1.5A,100-260VAC	CSMPA-22-3SR,1.5A,100-260VAC	0.3-1.5	85364900	
Relay CSMPM-06i-S (2a+1b) AC/DC85-260V 50/60Hz	CSMPM-06i-S(2A+1B)AC/DC85-260V 50/60HZ	0.5-6.0	85364900	
Relay CSMPM-06i-SE (2a+1b) AC/DC85-260V 50/60Hz	CSMPM-06i-SE(2A+1B)AC/DC85-260V 50/60HZ	0.5-6.0	85364900	
Relay CSMPM-06i-SI (2a+1b) AC/DC85-260V 50/60Hz	CSMPM-06i-SI(2A+1B)AC/DC85-260V 50/60HZ	0.5-6.0	85364900	
Relay CSMPM-06i-SM (2a+1b) AC/DC85-60V 50/60Hz	CSMPM-06i-SM(2A+1B)AC/DC85-60V 50/60HZ	0.5-6.0	85364900	
Relay CSMPM-06i-SZ (2a+1b) AC/DC85-260V 50/60Hz	CSMPM-06i-SZ(2A+1B)AC/DC85-260V 50/60HZ	0.5-6.0	85364900	
Relay CSMPM-06i-SZIA (2a+1b) AC/DC85-260V 50/60Hz	CSMPM-06i-SZIA(2A+1B)AC/DC85-260V50/60HZ	0.5-6.0	85364900	
Relay CSMPM-65i-S (2a+1b) AC/DC85-260V 50/60Hz	CSMPM-65i-S(2A+1B)AC/DC85-260V 50/60HZ	5.0-65	85364900	
Relay CSMPM-65i-SE (2a+1b) AC/DC85-260V 50/60Hz	CSMPM-65i-SE(2A+1B)AC/DC85-260V 50/60HZ	5.0-65	85364900	
Relay CSMPM-65i-SI (2a+1b) AC/DC85-260V 50/60Hz	CSMPM-65i-SI(2A+1B)AC/DC85-260V 50/60HZ	5.0-65	85364900	
Relay CSMPM-65i-SM (2a+1b) AC/DC85-260V 50/60Hz	CSMPM-65i-SM(2A+1B)AC/DC85-260V 50/60HZ	5.0-65	85364900	
Relay CSMPM-65i-SZ (2a+1b) AC/DC85-260V 50/60Hz	CSMPM-65i-SZ(2A+1B)AC/DC85-260V 50/60HZ	5.0-65	85364900	
IMC-IIIIM4852MAC110V50/60Hz	IMC-III-M485-2-MAC110V50/60Hz	6 / 60	85364900	
Relay IMP-CNOAC/DC85-245V	IMP-C-NO AC/DC85-245V	10 / 100	85364900	
Relay IMP-CA420AC/DC85-245V	IMP-C-A420 AC/DC85-245V	10 / 100	85364900	
Relay IMP-C-M485-AC/DC 85-245-40/60	IMP-C-M485-AC/DC 85-245-40/60	10 / 100	85364900	
Relay CSMPA-60-T,6A,220VAC	CSMPA-60-T,6A,220VAC	0.5-6.0	85364900	
Relay CSMPA-60-T,60A,220VAC	CSMPA-60-T,60A,220VAC	5.0-60	85364900	
Relay CSMPA-60-T,60A,110VAC	CSMPA-60-T,60A,110VAC	s5.0-60	85364900	
Relay CSMPA-60-T,6A,110VAC	CSMPA-60-T,6A,110VAC	0.5-6.0	85364900	
Relay CSMPA-60-T,60A,415VAC	CSMPA-60-T,60A,415VAC	5.0-60	85364900	
Relay CSMPA-60-T,6A,415VAC	CSMPA-60-T,6A,415VAC	0.5-6.0	85364900	

ACCESSORIES

Description	Reference	HSN Code	MRP (₹)
Display Cable-1-1.15 m	ASSY.,(1-1.5)CSMPM	85381090	POR
Display Cable-4 m	ASSY.,(4M)CSMPM	85381090	
Z-CTD with ID=30mm	Z-CTD30	85043100	
Z-CTD with ID=50mm	Z-CTD50	85043100	
Z-CTD with ID=65mm	Z-CTD65	85043100	
Z-CTD with ID=80mm	Z-CTD80	85043100	

ELR - Earth Leakage Relay

Models

ELR 1.0, ELR 3.0

Protection & Features

- Monitors, Detects & Protects Power system from Earth Leakage Fault
- Wide range of Selectable Earth Leakage Current Setting
- Configurable Earth Leakage Trip time 0-30s
- LED indication for Earth Leakage Fault & Alarm indication
- Trip Circuit Failure Indication
- Last 10 Fault records with date & time
- CBCT measures the leakage current to the highest accuracy
- Flush / DIN Rail mountable based on model selection



ELR 1.0



ELR 3.0

Description	Reference		HSN Code	MRP (₹)
Earth Leakage Relay ELR1.0 protection series, LED display with panel front mounting, current range (30mA-3A), Aux Supply (85-280V AC / 95-280V DC), CBCT Type Circular, ID 120 mm with plastic casing	ELR1.0-S-03-W-C120	30mA-3A	85364900	8180
Earth Leakage Relay ELR1.0 protection series, LED display with panel front mounting, current range (30mA-3A), Aux Supply (85-280V AC / 95-280V DC), CBCT Type Circular, ID 150 mm Resin Cast	ELR1.0-S-03-W-C150	30mA-3A	85364900	12580
Earth Leakage Relay ELR1.0 protection series, LED display with panel front mounting, current range (30mA-3A), Aux Supply (85-280V AC / 95-280V DC), CBCT Type Circular, ID 200 mm Resin cast	ELR1.0-S-03-W-C200	30mA-3A	85364900	15720
Earth Leakage Relay ELR1.0 protection series, LED display with panel front mounting, current range (30mA-3A), Aux Supply (85-280V AC / 95-280V DC), CBCT Type Circular, ID 57 mm with plastic casing	ELR-1.0-S-03-W-C55	30mA-3A	85364900	6290
Earth Leakage Relay ELR1.0 protection series, LED display with panel front mounting, current range (30mA-3A), Aux Supply (85-280V AC / 95-280V DC), CBCT Type Circular, ID 70 mm with plastic casing	ELR-1.0-S-03-W-C70	30mA-3A	85364900	6920
Earth Leakage Relay ELR1.0 protection series, LED display with panel front mounting, current range (30mA-3A), Aux Supply (85-280V AC / 95-280V DC), CBCT Type Circular, ID 92 mm with plastic casing	ELR-1.0-S-03-W-C90	30mA-3A	85364900	6920
Earth Leakage Relay ELR1.0 protection series, LED display with front panel mounting Current Range (30mA-3A), Aux Supply (85-280V AC/95-280V DC), CBCT Rectangular type ID 300 x 80 (CCT 300) Resin cast	ELR1.0-S-03-W-R300	30mA-3A	85364900	18860
Earth Leakage Relay ELR1.0 protection series, LED display with panel front mounting, current range (300mA-12A), Aux Supply (85-280V AC / 95-280V DC), CBCT Type Circular, ID 92 mm with plastic casing	ELR-1.0-S-12-W-C120	30mA-3A	85364900	8180
Earth Leakage Relay ELR1.0 protection series, LED display with panel front mounting, current range (300mA-12A), Aux Supply (85-280V AC / 95-280V DC), CBCT Type Circular, ID 120 mm with plastic casing	ELR-1.0-S-12-W-C90	30mA-3A	85364900	6920
Earth Leakage Relay ELR3.0 protection series, LCD display with panel front mounting, current range (300mA-12A), Aux Supply (85-280V AC / 95-280V DC), CBCT Type Circular, ID 120 mm with plastic casing	ELR-3.0-L-03-W-C120	30mA-3A	85364900	15720



Protection, Measurement & Control Devices

DG AMF / Synchronizing Controller

Models

EC2, EGA-250, EC-RXA, CD 2.0, CD 5.0

Protection & Features

- Display 3 Phase Mains Parameters: Voltage & Frequency
- Display of 3 Phase Generator Parameters: Voltage, Frequency, Speed, Run Hours
- Multi-genset Synchronizer & Load Share Unit
- Fault record with date & time stamp
- Event record with date & time stamp
- ATS / ATF / Remote Start Controller/ Engine Controller

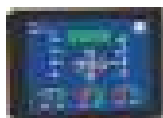

Description	Reference	HSN Code	MRP (₹)
Relay EC2(VER1.10)	EC2(VER1.10)	85364900	26410
Relay EC-RXA_V2	EC-RXA_V2	85364900	16040
Relay EGA-250-0	EGA-250-0	85364900	18860
Relay EC2(VER 2.10)	EC2-V2.10	85364900	26410
AMF Relay CD2.0 with MPU	AMF RELAY CD2.0 WITH MPU	85364900	20750
AMF Relay CD 5.0	AMF Relay CD 5.0	85364900	56590
Relay DG Synchronizer Relay CD5.0 with RS485/Ethernet	DG SYNC RELAY CD5.0 RS485/ETHERNET	85364900	189900
Relay EGC-250-0	EGC-250-0	85364900	20130

Voltage & Current Monitoring Relay & Timer

Model

Voltage Monitoring, Current Monitoring & Timers

Protection & features

- 3 Phase Voltage Monitoring
- 1 Phase Current Monitoring
- ON / OFF Delay Timer



Description	Reference	HSN Code	MRP (₹)
ENYA series- Multifunction Timer,Up to 7 functions,7 time ranges,Wide input voltage range	E1Z1E1024-240VAC/DC VE10 (110204A)	85364900	9690
Monitoring relays - ENYA series, Voltage monitoring in 3- and 1-phase mains	E1YM400VS10 (1340405H)	85364900	5980
Monitoring relays - GAMMA series, AC/DC current monitoring in 1-phase mains	G2IM10AL20,24-240V (2390410)	85364900	30180
ENYA series-Multifunction Timer,Up to 7 functions,7 time ranges,Wide input voltage range	E1ZM10 12-240VAC/DC	85364900	10060
Monitoring relays - ENYA series, Tripping unit for temperature monitoring	E3TF01 230VAC	85364900	16360
Monitoring relays - ENYA series - AC/DC current monitoring in 1-phase mains	E3IM10AL20,230VAC (1341200)	85364900	25400
ENYA series, Timers - Multifunctional,Up to 7 functions,7 time ranges,Wide input voltage range	E1ZMQ10,24-240VAC/DC	85364900	10060
ENYA series- Timers - Asymmetric flasher	E1Z1I10 12-240VAC/DC	85364900	10060
Monitoring relays - GAMMA series,Voltage monitoring in 3-phase mains	G2PM690VSY20	85364900	31450
Monitoring relays - GAMMA series, Voltage monitoring in 3-phase mains	G2PM400VSY20(2390504)	85364900	23270
Monitoring relays - GAMMA series,a.c./d.c. current monitoring in 1-phase mains	G2IM5AL20,24-240V	85364900	30180
Monitoring relays - GAMMA series, a.c./d.c. current monitoring in 1-phase mains	G2IM10AL20 24-240V AC/DC	85364900	30180
Monitoring Relays-TR Series	TR2-400VAC(282117)	85364900	3020



Protection, Measurement & Control Devices

CSTSM-WD (Wired Temperature Sensor)



- Wide ambient temperature monitoring range: 0°C to 200°C
- Supports up to 6 temperature sensors with a single main module
- Temperature accuracy upto + 3°C
- Relay is capable of supervising both Alarm and trip condition.
- ADD-ON display module for Temperature monitoring
- RS-485 port for SCADA Communication
- Over Temperature Trip Fault Record with Date & Time stamp
- Two Potential free Digital outputs (Relay ON / OFF)
- Two User configurable Digital inputs
- Supply voltage: 18-60V DC
- 12x2 Alpha numeric bright display
- LED indication for Temperature Trip and Temperature Alarm.
 - 1 LED for TRIP on fault
 - 1 LINK LED for communication link between Base & display indication.
 - 1 ALARM LED for over temperature indication.
- Power Consumption: 6VA

*For MRP & other details please contact to nearest Branch Office.

CSTSM-WL (Wireless Temperature Sensor)



- Wide ambient temperature monitoring range: -20°C to 145°C
- Supports up to 50 thermal nodes with a single receiver
- Temperature accuracy upto 0.2°C
- Battery-less thermal nodes with energy harvesting at 20A of current for temperature monitoring
- RS-485 Modbus port for SCADA integration
- Front USB communication for PC / Laptop Interface
- Over-temperature trip fault recording with date and time stamp
- Power consumption: 6VA
- Two potential-free Digital outputs (Relay ON / OFF)
- Two user-configurable Digital inputs
- Receiver supply voltage: 18-60V DC / 500mA
- LED indicators for Temperature Trip and Temperature Alarm
- LED indicator for Trip on fault
- Alarm LED for Over-Temperature indication

*For MRP & other details please contact to nearest Branch Office.

ORDERING INFORMATION

CSTSM WD - XX - X - XX - XX

DISPLAY MODULE	
DN	: Without Display module
DB	: With 12x2 Basic Display module

AUXILIARY SUPPLY	
L	: 18 - 60V DC
W	: 90 - 264V AC/DC

LENGTH OF SENSOR	
01	One Meter
02	Two Meter
03	Three Meter
04	Four Meter
05	Five Meter

NO. OF SENSOR	
01	One Number
02	Two Number
03	Three Number
04	Four Number
05	Five Number
06	Six Number

Example : CSTSM-WD-DB-W-03-06

Final Power **Distribution** Components



Miniature Circuit Breakers ■ Residual Current Circuit Breakers
RCBOs ■ Isolators ■ MCB Type Changeover Switches ■ ACCLs
Distribution Boards ■ Smart Distribution Boards ■ Cable End Boxes
Plugs & Socket DBs ■ MCB Enclosures



WiNtrip2 Miniature Circuit Breaker



Two stage easy snapping device for Din Rail Mounting

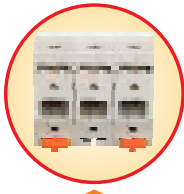

Bi-connect terminals for Cable and Busbar

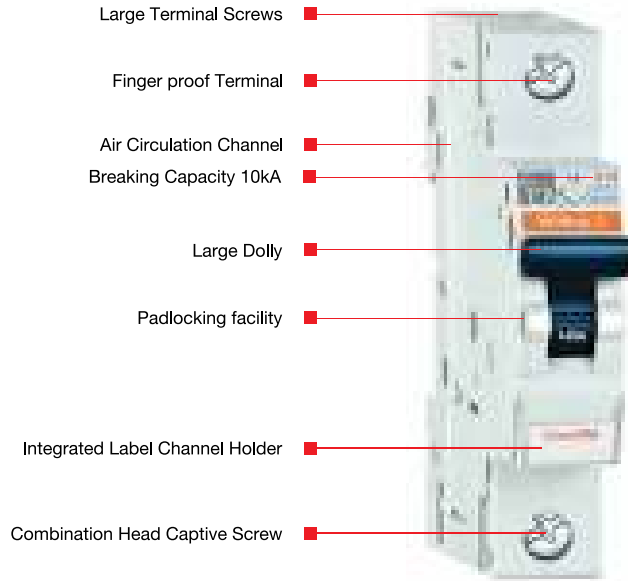

B-Series

Lighting & Distribution with no Surge Current

[HSN Code: 8536]

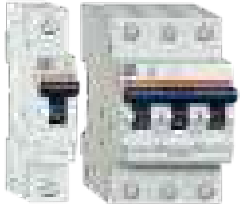

Current rating (Amps.)	Product Code	MRP (₹)	Std. Pkg. (Nos.)
1 Pole			
6	CSMBS1B6	300	12
10	CSMBS1B10	300	
16	CSMBS1B16	300	
20	CSMBS1B20	300	
25	CSMBS1B25	300	
32	CSMBS1B32	300	
40	CSMBS1B40	700	
50	☒ CSMBS1B50	790	
63	CSMBS1B63	790	

Current rating (Amps.)	Product Code	MRP (₹)	Std. Pkg. (Nos.)
3 Pole			
6	CSMBS3B6	1650	4
10	CSMBS3B10	1650	
16	CSMBS3B16	1650	
20	CSMBS3B20	1650	
25	CSMBS3B25	1650	
32	CSMBS3B32	1650	
40	CSMBS3B40	2450	
50	☒ CSMBS3B50	2450	
63	CSMBS3B63	2450	



Current rating (Amps.)	Product Code	MRP (₹)	Std. Pkg. (Nos.)
1 Pole + N			
6	CSMBS1B6N	990	6
10	CSMBS1B10N	990	
16	CSMBS1B16N	990	
20	CSMBS1B20N	990	
25	CSMBS1B25N	990	
32	CSMBS1B32N	990	
40	CSMBS1B40N	1440	
50	☒ CSMBS1B50N	1630	
63	CSMBS1B63N	1630	

Current rating (Amps.)	Product Code	MRP (₹)	Std. Pkg. (Nos.)
3 Pole + N			
6	☒ CSMBS3B6N	2150	3
10	☒ CSMBS3B10N	2150	
16	CSMBS3B16N	2150	
20	☒ CSMBS3B20N	2150	
25	☒ CSMBS3B25N	2150	
32	CSMBS3B32N	2150	
40	CSMBS3B40N	2880	
50	☒ CSMBS3B50N	3190	
63	CSMBS3B63N	3190	

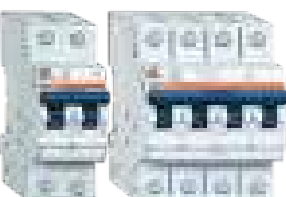

Current rating (Amps.)	Product Code	MRP (₹)	Std. Pkg. (Nos.)
2 Pole			
6	CSMBS2B6	1100	6
10	CSMBS2B10	1100	
16	CSMBS2B16	1100	
20	CSMBS2B20	1100	
25	CSMBS2B25	1100	
32	CSMBS2B32	1100	
40	CSMBS2B40	1550	
50	☒ CSMBS2B50	1800	
63	CSMBS2B63	1800	

Current rating (Amps.)	Product Code	MRP (₹)	Std. Pkg. (Nos.)
4 Pole			
6	☒ CSMBS4B6	2380	3
10	☒ CSMBS4B10	2380	
16	☒ CSMBS4B16	2380	
20	☒ CSMBS4B20	2380	
25	☒ CSMBS4B25	2380	
32	CSMBS4B32	2380	
40	CSMBS4B40	3120	
50	CSMBS4B50	3330	
63	CSMBS4B63	3330	

☒ Non Stockable item

WiNtrip2 Miniature Circuit Breaker

C-Series

Inductive load with surge current - Motor Circuit Applications

[HSN Code: 8536]



Current rating (Amps.)	Product Code	MRP (₹)	Std. Pkg. (Nos.)
1 Pole			
0.5	☒CSMBS1C0.5	530	12
1	CSMBS1C1	530	
2	CSMBS1C2	530	
3	☒CSMBS1C3	530	
4	CSMBS1C4	530	
5	☒CSMBS1C5	530	
6	CSMBS1C6	310	
10	CSMBS1C10	310	
16	CSMBS1C 16	310	
20	CSMBS1C20	310	
25	CSMBS1C25	310	
32	CSMBS1C32	310	
40	CSMBS1C40	750	
50	☒CSMBS1C50	800	
63	CSMBS1C63	800	

Current rating (Amps.)	Product Code	MRP (₹)	Std. Pkg. (Nos.)
3 Pole			
0.5	☒CSMBS3C0.5	2170	4
1	☒CSMBS3C1	2170	
2	CSMBS3C2	2170	
3	☒CSMBS3C3	2170	
4	☒CSMBS3C4	2170	
5	CSMBS3C5	2170	
6	CSMBS3C6	1740	
10	CSMBS3C10	1740	
16	CSMBS3C16	1740	
20	CSMBS3C20	1740	
25	CSMBS3C25	1740	
32	CSMBS3C32	1740	
40	CSMBS3C40	2580	
50	CSMBS3C50	2690	
63	CSMBS3C63	2690	



Current rating (Amps.)	Product Code	MRP (₹)	Std. Pkg. (Nos.)
1 Pole + N			
0.5	CSMBS1C0.5N	1490	6
1	☒CSMBS1C1N	1490	
2	☒CSMBS1C2N	1490	
3	☒CSMBS1C3N	1490	
4	CSMBS1C4N	1490	
5	CSMBS1C5N	1490	
6	☒CSMBS1C6N	1060	
10	CSMBS1C10N	1060	
16	CSMBS1C16N	1060	
20	CSMBS1C20N	1060	
25	☒CSMBS1C25N	1060	
32	CSMBS1C32N	1060	
40	☒CSMBS1C40N	1530	
50	☒CSMBS1C50N	1730	
63	CSMBS1C63N	1730	

Current rating (Amps.)	Product Code	MRP (₹)	Std. Pkg. (Nos.)
3 Pole + N			
0.5	CSMBS3C0.5N	2820	3
1	CSMBS3C1N	2820	
2	☒CSMBS3C2N	2820	
3	CSMBS3C3N	2820	
4	CSMBS3C4N	2820	
5	CSMBS3C5N	2820	
6	CSMBS3C6N	2220	
10	☒CSMBS3C10N	2220	
16	CSMBS3C16N	2220	
20	CSMBS3C20N	2220	
25	CSMBS3C25N	2220	
32	CSMBS3C32N	2220	
40	CSMBS3C40N	3010	
50	☒CSMBS3C50N	3200	
63	CSMBS3C63N	3200	

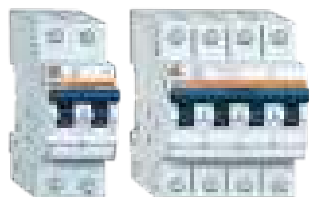

Current rating (Amps.)	Product Code	MRP (₹)	Std. Pkg. (Nos.)
2 Pole			
0.5	CSMBS2C0.5	1540	6
1	☒CSMBS2C1	1540	
2	CSMBS2C2	1540	
3	☒CSMBS2C3	1540	
4	CSMBS2C4	1540	
5	CSMBS2C5	1540	
6	CSMBS2C6	1100	
10	CSMBS2C10	1100	
16	CSMBS2C16	1100	
20	CSMBS2C20	1100	
25	CSMBS2C25	1100	
32	CSMBS2C32	1100	
40	CSMBS2C40	1630	
50	☒CSMBS2C50	1840	
63	CSMBS2C63	1840	

Current rating (Amps.)	Product Code	MRP (₹)	Std. Pkg. (Nos.)
4 Pole			
0.5	CSMBS4C0.5	3000	3
1	CSMBS4C1	3000	
2	☒CSMBS4C2	3000	
3	CSMBS4C3	3000	
4	☒CSMBS4C4	3000	
5	CSMBS4C5	3000	
6	CSMBS4C6	2450	
10	CSMBS4C10	2450	
16	CSMBS4C16	2450	
20	CSMBS4C20	2450	
25	CSMBS4C25	2450	
32	CSMBS4C32	2450	
40	CSMBS4C40	3360	
50	CSMBS4C50	3480	
63	CSMBS4C63	3480	

☒ Non Stockable item



WiNtrip2 Miniature Circuit Breaker

D-Series
High Inductive Load & High Inrush Current

[HSN Code: 8536]



Current rating (Amps.)	Product Code	MRP (₹)	Std. Pkg. (Nos.)
1 Pole			
0.5	CSMBS1D0.5	600	12
1	CSMBS1D1	600	
2	☒CSMBS1D2	600	
3	CSMBS1D3	600	
4	CSMBS1D4	600	
5	CSMBS1D5	600	
6	☒CSMBS1D6	500	
10	☒CSMBS1D10	500	
16	☒CSMBS1D16	500	
20	☒CSMBS1D20	500	
25	☒CSMBS1D25	500	
32	☒CSMBS1D32	500	
40	CSMBS1D40	840	
50	CSMBS1D50	950	
63	CSMBS1D63	950	

Current rating (Amps.)	Product Code	MRP (₹)	Std. Pkg. (Nos.)
3 Pole			
0.5	CSMBS3D0.5	2430	4
1	CSMBS3D1	2430	
2	CSMBS3D2	2430	
3	CSMBS3D3	2430	
4	CSMBS3D4	2430	
5	CSMBS3D5	2430	
6	☒CSMBS3D6	1920	
10	CSMBS3D10	1920	
16	☒CSMBS3D16	1920	
20	☒CSMBS3D20	1920	
25	☒CSMBS3D25	1920	
32	☒CSMBS3D32	1920	
40	☒CSMBS3D40	2910	
50	CSMBS3D50	3010	
63	☒CSMBS3D63	3010	



Current rating (Amps.)	Product Code	MRP (₹)	Std. Pkg. (Nos.)
1 Pole + N			
0.5	CSMBS1D0.5N	1530	6
1	CSMBS1D1N	1530	
2	CSMBS1D2N	1530	
3	CSMBS1D3N	1530	
4	CSMBS1D4N	1530	
5	CSMBS1D5N	1530	
6	CSMBS1D6N	1210	
10	CSMBS1D10N	1210	
16	CSMBS1D16N	1210	
20	CSMBS1D20N	1210	
25	CSMBS1D25N	1210	
32	☒CSMBS1D32N	1210	
40	CSMBS1D40N	1800	
50	CSMBS1D50N	1920	
63	☒CSMBS1D63N	1920	

Current rating (Amps.)	Product Code	MRP (₹)	Std. Pkg. (Nos.)
3 Pole + N			
0.5	CSMBS3D0.5N	3130	3
1	CSMBS3D1N	3130	
2	CSMBS3D2N	3130	
3	CSMBS3D3N	3130	
4	CSMBS3D4N	3130	
5	CSMBS3D5N	3130	
6	CSMBS3D6N	2860	
10	CSMBS3D10N	2860	
16	☒CSMBS3D16N	2860	
20	CSMBS3D20N	2860	
25	☒CSMBS3D25N	2860	
32	☒CSMBS3D32N	2860	
40	CSMBS3D40N	3160	
50	CSMBS3D50N	3310	
63	☒CSMBS3D63N	3310	



Current rating (Amps.)	Product Code	MRP (₹)	Std. Pkg. (Nos.)
2 Pole			
0.5	☒CSMBS2D0.5	1630	6
1	CSMBS2D1	1630	
2	☒CSMBS2D2	1630	
3	CSMBS2D3	1630	
4	☒CSMBS2D4	1630	
5	CSMBS2D5	1630	
6	☒CSMBS2D6	1290	
10	☒CSMBS2D10	1290	
16	☒CSMBS2D16	1290	
20	☒CSMBS2D20	1290	
25	☒CSMBS2D25	1290	
32	☒CSMBS2D32	1290	
40	CSMBS2D40	1880	
50	CSMBS2D50	1960	
63	☒CSMBS2D63	1960	

Current rating (Amps.)	Product Code	MRP (₹)	Std. Pkg. (Nos.)
4 Pole			
0.5	CSMBS4D0.5	3200	3
1	CSMBS4D1	3200	
2	CSMBS4D2	3200	
3	CSMBS4D3	3200	
4	CSMBS4D4	3200	
5	CSMBS4D5	3200	
6	CSMBS4D6	2940	
10	CSMBS4D10	2940	
16	☒CSMBS4D16	2940	
20	CSMBS4D20	2940	
25	CSMBS4D25	2940	
32	CSMBS4D32	2940	
40	☒CSMBS4D40	3570	
50	CSMBS4D50	3920	
63	☒CSMBS4D63	3920	

☒ Non Stockable item

WiNtrip2 Miniature Circuit Breaker

K-Series, 'C' Curve

IS/IEC 60947-2

Inductive load with surge current - Motor Circuit Applications

[HSN Code: 8536]



Current rating (Amps.)	Product Code	MRP (₹)	Std. Pkg. (Nos.)
1 Pole			
0.5	CSMBS1K0.5	610	12
1	CSMBS1K1	610	
2	CSMBS1K2	610	
3	CSMBS1K3	610	
4	CSMBS1K4	610	
5	CSMBS1K5	610	
6	CSMBS1K6	390	
10	CSMBS1K10	390	
16	CSMBS1K16	390	
20	CSMBS1K20	390	
25	CSMBS1K25	390	
32	CSMBS1K32	390	
40	CSMBS1K40	860	
50	CSMBS1K50	950	
63	CSMBS1K63	950	

Current rating (Amps.)	Product Code	MRP (₹)	Std. Pkg. (Nos.)
3 Pole			
0.5	CSMBS3K0.5	2440	4
1	CSMBS3K1	2440	
2	CSMBS3K2	2440	
3	CSMBS3K3	2440	
4	CSMBS3K4	2440	
5	CSMBS3K5	2440	
6	CSMBS3K6	2020	
10	CSMBS3K10	2020	
16	CSMBS3K16	2020	
20	CSMBS3K20	2020	
25	CSMBS3K25	2020	
32	CSMBS3K32	2020	
40	CSMBS3K40	2940	
50	CSMBS3K50	3130	
63	CSMBS3K63	3130	

Current rating (Amps.)	Product Code	MRP (₹)	Std. Pkg. (Nos.)
1 Pole + N			
0.5	CSMBS1K0.5N	1670	6
1	CSMBS1K1N	1670	
2	CSMBS1K2N	1670	
3	CSMBS1K3N	1670	
4	CSMBS1K4N	1670	
5	CSMBS1K5N	1670	
6	CSMBS1K6N	1190	
10	CSMBS1K10N	1190	
16	CSMBS1K16N	1190	
20	CSMBS1K20N	1190	
25	CSMBS1K25N	1190	
32	CSMBS1K32N	1190	
40	CSMBS1K40N	1700	
50	CSMBS1K50N	1920	
63	CSMBS1K63N	1920	

Current rating (Amps.)	Product Code	MRP (₹)	Std. Pkg. (Nos.)
3 Pole + N			
0.5	CSMBS3K0.5N	3150	3
1	CSMBS3K1N	3150	
2	CSMBS3K2N	3150	
3	CSMBS3K3N	3150	
4	CSMBS3K4N	3150	
5	CSMBS3K5N	3150	
6	CSMBS3K6N	2570	
10	CSMBS3K10N	2570	
16	CSMBS3K16N	2570	
20	CSMBS3K20N	2570	
25	CSMBS3K25N	2570	
32	CSMBS3K32N	2570	
40	CSMBS3K40N	3450	
50	CSMBS3K50N	3710	
63	CSMBS3K63N	3710	



Current rating (Amps.)	Product Code	MRP (₹)	Std. Pkg. (Nos.)
2 Pole			
0.5	CSMBS2K0.5	1750	6
1	CSMBS2K1	1750	
2	CSMBS2K2	1750	
3	CSMBS2K3	1750	
4	CSMBS2K4	1750	
5	CSMBS2K5	1750	
6	CSMBS2K6	1260	
10	CSMBS2K10	1260	
16	CSMBS2K16	1260	
20	CSMBS2K20	1260	
25	CSMBS2K25	1260	
32	CSMBS2K32	1260	
40	CSMBS2K40	1880	
50	CSMBS2K50	2130	
63	CSMBS2K63	2130	

Current rating (Amps.)	Product Code	MRP (₹)	Std. Pkg. (Nos.)
4 Pole			
0.5	CSMBS4K0.5	3360	3
1	CSMBS4K1	3360	
2	CSMBS4K2	3360	
3	CSMBS4K3	3360	
4	CSMBS4K4	3360	
5	CSMBS4K5	3360	
6	CSMBS4K6	2860	
10	CSMBS4K10	2860	
16	CSMBS4K16	2860	
20	CSMBS4K20	2860	
25	CSMBS4K25	2860	
32	CSMBS4K32	2860	
40	CSMBS4K40	3820	
50	CSMBS4K50	4130	
63	CSMBS4K63	4130	



Non Stockable item

Note: K- Series 'B' Curve POR (for prices please contact the nearest branch office.)



WIntrip2 DC MCB

- 250V (SP) & 500V (DP), 3kA / 6kA breaking capacity
- Range: 6A–40A
- Standard Conformity: IEC60947-2:2015

WiNtrip2 Miniature Circuit Breaker

DC MCB-Series

[HSN Code: 8536]

Description	Current rating (Amps.)	Product Code	MRP (₹)	Std. Pkg. (Nos.)
1 Pole				
DC MCB SP 6A-250V	6	CSMBS1DC6-250	680	12
DC MCB SP 10A-250V	10	CSMBS1DC10-250	680	
DC MCB SP 16A-250V	16	CSMBS1DC16-250	680	
DC MCB SP 20A-250V	20	CSMBS1DC20-250	680	
DC MCB SP 25A-250V	25	CSMBS1DC25-250	680	
DC MCB SP 32A-250V	32	CSMBS1DC32-250	680	
DC MCB SP 40A-250V	40	CSMBS1DC40-250	950	
Shorting link		SHMT8101	130	
2 Pole				
DC MCB DP 6A-500V	6	CSMBS2DC6-500	1440	6
DC MCB DP 10A-500V	10	CSMBS2DC10-500	1440	
DC MCB DP 16A-500V	16	CSMBS2DC16-500	1440	
DC MCB DP 20A-500V	20	CSMBS2DC20-500	1440	
DC MCB DP 25A-500V	25	CSMBS2DC25-500	1440	
DC MCB DP 32A-500V	32	CSMBS2DC32-500	1440	
DC MCB DP 40A-500V	40	CSMBS2DC40-500	2060	
Shorting link		SHMT8101	130	



DC MCB-Series

[HSN Code: 8536]

Current rating (Amps.)	Product Code	MRP (₹)	Std. Pkg. (Nos.)	Current rating (Amps.)	Product Code	MRP (₹)	Std. Pkg. (Nos.)
1 Pole				2 Pole			
0.5	<input checked="" type="checkbox"/> CSMBS1DC0.5	710	12	0.5	CSMBS2DC0.5	1680	6
1	<input checked="" type="checkbox"/> CSMBS1DC1	710		1	CSMBS2DC1	1680	
2	<input checked="" type="checkbox"/> CSMBS1DC2	710		2	<input checked="" type="checkbox"/> CSMBS2DC2	1680	
3	CSMBS1DC3	710		3	CSMBS2DC3	1680	
4	<input checked="" type="checkbox"/> CSMBS1DC4	710		4	CSMBS2DC4	1680	
5	<input checked="" type="checkbox"/> CSMBS1DC5	710		5	CSMBS2DC5	1680	
6	CSMBS1DC6	610		6	CSMBS2DC6	1300	
10	<input checked="" type="checkbox"/> CSMBS1DC10	610		10	CSMBS2DC10	1300	
16	<input checked="" type="checkbox"/> CSMBS1DC16	610		16	CSMBS2DC16	1300	
20	<input checked="" type="checkbox"/> CSMBS1DC20	610		20	CSMBS2DC20	1300	
25	<input checked="" type="checkbox"/> CSMBS1DC25	610		25	CSMBS2DC25	1300	
32	<input checked="" type="checkbox"/> CSMBS1DC32	610		32	CSMBS2DC32	1300	
40	<input checked="" type="checkbox"/> CSMBS1DC40	860		40	<input checked="" type="checkbox"/> CSMBS2DC40	1820	
50	<input checked="" type="checkbox"/> CSMBS1DC50	1000		50	<input checked="" type="checkbox"/> CSMBS2DC50	2050	
63	<input checked="" type="checkbox"/> CSMBS1DC63	1000		63	CSMBS2DC63	2050	

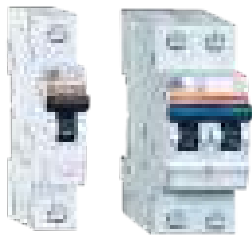

Accessories (Site fit-able)

[HSN Code: 8538]

Description	Product Code	Configuration	Type of contact	Fitment	Module Size	Suitable MCB Rating (A)	MRP (₹)	Std. Pkg. (Nos.)
Auxiliary Contact	CSMBAXSF1	1NO-1NC	Changeover	Right	9 mm	Wintrip2 0.5-63	1210	12
Auxiliary Contact	CSMBAXSF2	2NO-2NC	Changeover	Right	9 mm	Wintrip2 0.5-63	1260	
Auxiliary Contact	CSMBAXSF11	1NO-1NC	Potential free	Left	18 mm	Wintrip2 0.5-63	1210	
Alarm Contact	CSMBALSF1	1 Changeover	Changeover	Right	9 mm	Wintrip2 0.5-63	1050	12
Shunt Trip	CSMBS012DCSF	-	-	Left	18 mm	Wintrip2 0.5-63	1440	6
Shunt Trip	CSMBS024DCSF	-	-	Left	18 mm	Wintrip2 0.5-63	1440	
Shunt Trip	CSMBS048DCSF	-	-	Left	18 mm	Wintrip2 0.5-63	1440	
Shunt Trip	CSMBS220ACSF	-	-	Left	18 mm	Wintrip2 0.5-63	1440	

Non Stockable item



WiNtrip2 Isolator (IEC 60947-3)

[HSN Code: 8536]

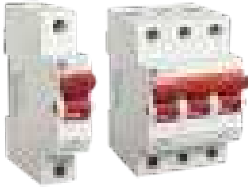

Current rating (Amps.)	Product Code	MRP (₹)	Std. Pkg. (Nos.)
1 Pole			
25	CSMBS1SD25	410	12
40	CSMBS1SD40	540	
63	CSMBS1SD63	590	
80	CSMBS1SD80	670	
100	CSMBS1SD100	780	
125	CSMBS1SD125	910	

Current rating (Amps.)	Product Code	MRP (₹)	Std. Pkg. (Nos.)
3 Pole			
25	CSMBS3SD25	1290	4
40	CSMBS3SD40	1480	
63	CSMBS3SD63	1660	
80	CSMBS3SD80	1890	
100	CSMBS3SD100	1960	
125	CSMBS3SD125	2070	



Current rating (Amps.)	Product Code	MRP (₹)	Std. Pkg. (Nos.)
2 Pole			
25	CSMBS2SD25	680	6
40	CSMBS2SD40	770	
63	CSMBS2SD63	960	
80	CSMBS2SD80	1210	
100	CSMBS2SD100	1240	
125	CSMBS2SD125	1390	

Current rating (Amps.)	Product Code	MRP (₹)	Std. Pkg. (Nos.)
4 Pole			
25	CSMBS4SD25	1370	3
40	CSMBS4SD40	1690	
63	CSMBS4SD63	1860	
80	CSMBS4SD80	2290	
100	CSMBS4SD100	2320	
125	CSMBS4SD125	2560	

[HSN Code: 8536]

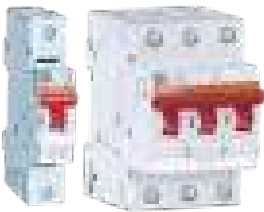

Current rating (Amps.)	Product Code	MRP (₹)	Std. Pkg. (Nos.)
1 Pole			
25	<input checked="" type="checkbox"/> CSMBS1ISO25	370	12
40	<input checked="" type="checkbox"/> CSMBS1ISO40	490	
63	<input checked="" type="checkbox"/> CSMBS1ISO63	550	
80	CSMBS1ISO80	610	
100	<input checked="" type="checkbox"/> CSMBS1ISO100	700	
125	<input checked="" type="checkbox"/> CSMBS1ISO125	830	

Current rating (Amps.)	Product Code	MRP (₹)	Std. Pkg. (Nos.)
3 Pole			
25	CSMBS3ISO25	1140	4
40	CSMBS3ISO40	1300	
63	CSMBS3ISO63	1470	
80	<input checked="" type="checkbox"/> CSMBS3ISO80	1680	
100	CSMBS3ISO100	1730	
125	<input checked="" type="checkbox"/> CSMBS3ISO125	1830	



Current rating (Amps.)	Product Code	MRP (₹)	Std. Pkg. (Nos.)
2 Pole			
25	CSMBS2ISO25	620	6
40	CSMBS2ISO40	680	
63	CSMBS2ISO63	860	
80	<input checked="" type="checkbox"/> CSMBS2ISO80	1090	
100	CSMBS2ISO100	1110	
125	CSMBS2ISO125	1240	

Current rating (Amps.)	Product Code	MRP (₹)	Std. Pkg. (Nos.)
4 Pole			
25	<input checked="" type="checkbox"/> CSMBS4ISO25	1210	3
40	CSMBS4ISO40	1490	
63	CSMBS4ISO63	1650	
80	<input checked="" type="checkbox"/> CSMBS4ISO80	2030	
100	CSMBS4ISO100	2060	
125	CSMBS4ISO125	2280	

Higher Rating Miniature Circuit Breakers (IEC 60947-2)

[HSN Code: 8536]

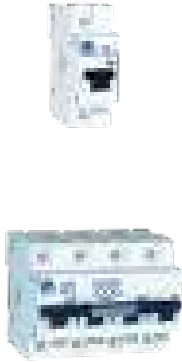

Current rating (Amps.)	Product Code	MRP (₹)	Std. Pkg. (Nos.)	Current rating (Amps.)	Product Code	MRP (₹)	Std. Pkg. (Nos.)
1 Pole				3 Pole			
80	CSMBH1C80	2920	8	80	CSMBH3C80	10310	3
100	CSMBH1C100	3270		100	CSMBH3C100	10980	
125	CSMBH1C125	3540		125	CSMBH3C125	12190	
2 Pole				4 Pole			
80	CSMBH2C80	6530	4	80	CSMBH4C80	13130	2
100	CSMBH2C100	6980		100	CSMBH4C100	13690	
125	CSMBH2C125	7680		125	CSMBH4C125	15460	

Accessories (Site fit-able)

[HSN Code: 8538]

Description	Product Code	Configuration	Type of contact	Fitment	Module Size	Suitable MCB Rating (A)	MRP (₹)	Std. Pkg. (Nos.)
Auxiliary Contact	CSMBAXHSF1	1NO-1NC	Changeover	Right	9 mm	Wintrip2 80-100	1310	12
Auxiliary Contact	CSMBAXHSF2	2NO-2NC	Changeover	Right	9 mm	Wintrip2 80-100	1380	
Alarm Contact	CSMBALHSF1	1 Changeover	Changeover	Right	9 mm	Wintrip2 80-100	1310	
Shunt Trip	CSMBHS012DCSF	-	-	Left	18 mm	Wintrip2 80-100	1540	6
Shunt Trip	CSMBHS024DCSF	-	-	Left	18 mm	Wintrip2 80-100	1540	
Shunt Trip	CSMBHS048DCSF	-	-	Left	18 mm	Wintrip2 80-100	1540	
Shunt Trip	CSMBHS220ACSF	-	-	Left	18 mm	Wintrip2 80-100	1540	

Wintrip MCB Type Changeover Switch

[HSN Code: 8536]



Description	Pole	Rating (Amps.)	Product Code	MRP (₹)	Std. Pkg. (Nos.)
2 Pole					
Two way centre OFF Changeover Switch	2	25	CSCOS2P25A	2110	6
Two way centre OFF Changeover Switch	2	40	CSCOS2P40A	3130	
Two way centre OFF Changeover Switch	2	63	CSCOS2P63A	3620	
4 Pole					
Two way centre OFF Changeover Switch	4	25	CSCOS4P25A	3990	3
Two way centre OFF Changeover Switch	4	40	CSCOS4P40A	5970	
Two way centre OFF Changeover Switch	4	63	CSCOS4P63A	6420	

SmartSol Mini MCB DP

[HSN Code: 8536]

Description	Current rating (Amps.)	Reference	MRP (₹)
DP "C" 6-32A Mini MCB with Enclosure	6-32	CSMBSS2C6-32	700
SPN "C" 6-32A Mini MCB with Enclosure	6-32	CSMBSS1C6-32*N	700

Non Stockable item

WiNtrip2

RCBO

RCCB with
Over-current Protection



- Range: 6~40A SPN (2 Module), 6~63A, 2P (4 Module) & 4P (8 Module)
- Standard IEC 60947-2 Annexure-B
- RoHS Compliance, conformity to EU ROHS Directive 2015/863/EU
- Ingress Protection: IP20
- Pad locking facility for maintenance and critical loads
- It can withstand abnormal heating and strong impact
- Humidity should not exceeding 50% at 40°C and not exceeding 90% at 25°C
- Pollution degree 2
- Installation class II or III
- Ambient operating temperature 30°C
- The 35 Sq. mm Terminal is designed to incorporate wires of bigger sizes

WiNtrip2 RCBO

RCCB with Over-current Protection



SPN (2 Module)		[HSN Code: 8536]	
Product Code	MRP (₹)	Std. Pkg. (Nos.)	
30mA 10kA			
CSRCBOSPNC06A30-10KA	4330	5	
CSRCBOSPNC10A30-10KA	4330		
CSRCBOSPNC16A30-10KA	4330		
CSRCBOSPNC20A30-10KA	4330		
CSRCBOSPNC25A30-10KA	4330		
CSRCBOSPNC32A30-10KA	4330		
CSRCBOSPNC40A30-10KA	4330		
100mA 10kA			
CSRCBOSPNC06A100-10KA	4420	5	
CSRCBOSPNC10A100-10KA	4420		
CSRCBOSPNC16A100-10KA	4420		
CSRCBOSPNC20A100-10KA	4420		
CSRCBOSPNC25A100-10KA	4420		
CSRCBOSPNC32A100-10KA	4420		
CSRCBOSPNC40A100-10KA	4420		
3100mA 10kA			
CSRCBOSPNC06A300-10KA	4480	5	
CSRCBOSPNC10A300-10KA	4480		
CSRCBOSPNC16A300-10KA	4480		
CSRCBOSPNC20A300-10KA	4480		
CSRCBOSPNC25A300-10KA	4480		
CSRCBOSPNC32A300-10KA	4480		
CSRCBOSPNC40A300-10KA	4480		

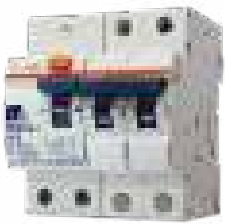

2 Pole (4 Module)			4 Pole (8 Module)			[HSN Code: 8536]		
Product Code	MRP (₹)	Std. Pkg. (Nos.)	Product Code	MRP (₹)	Std. Pkg. (Nos.)			
30mA 10kA			30mA 10kA					
CSRCBO2PC06A30-10KA	4480	4	CSRCBO4PC06A30-10KA	5290	2			
CSRCBO2PC10A30-10KA	4480		CSRCBO4PC10A30-10KA	5290				
CSRCBO2PC16A30-10KA	4480		CSRCBO4PC16A30-10KA	5290				
CSRCBO2PC20A30-10KA	4480		CSRCBO4PC20A30-10KA	5290				
CSRCBO2PC25A30-10KA	4480		CSRCBO4PC25A30-10KA	5290				
CSRCBO2PC32A30-10KA	4480		CSRCBO4PC32A30-10KA	5460				
CSRCBO2PC40A30-10KA	4480		CSRCBO4PC40A30-10KA	5550				
CSRCBO2PC63A30-10KA	5610		CSRCBO4PC63A30-10KA	6640				
100mA 10kA			100mA 10kA					
CSRCBO2PC06A100-10KA	4570	4	CSRCBO4PC06A100-10KA	5890	2			
CSRCBO2PC10A100-10KA	4570		CSRCBO4PC10A100-10KA	5890				
CSRCBO2PC16A100-10KA	4570		CSRCBO4PC16A100-10KA	5890				
CSRCBO2PC20A100-10KA	4570		CSRCBO4PC20A100-10KA	5890				
CSRCBO2PC25A100-10KA	4570		CSRCBO4PC25A100-10KA	5890				
CSRCBO2PC32A100-10KA	4570		CSRCBO4PC32A100-10KA	5890				
CSRCBO2PC40A100-10KA	4570		CSRCBO4PC40A100-10KA	5890				
CSRCBO2PC63A100-10KA	5950		CSRCBO4PC63A100-10KA	6770				
300mA 10kA			300mA 10kA					
CSRCBO2PC06A300-10KA	4630	4	CSRCBO4PC06A300-10KA	6000	2			
CSRCBO2PC10A300-10KA	4630		CSRCBO4PC10A300-10KA	6000				
CSRCBO2PC16A300-10KA	4630		CSRCBO4PC16A300-10KA	6000				
CSRCBO2PC20A300-10KA	4630		CSRCBO4PC20A300-10KA	6000				
CSRCBO2PC25A300-10KA	4630		CSRCBO4PC25A300-10KA	6000				
CSRCBO2PC32A300-10KA	4630		CSRCBO4PC32A300-10KA	6020				
CSRCBO2PC40A300-10KA	4630		CSRCBO4PC40A300-10KA	6040				
CSRCBO2PC63A300-10KA	6000		CSRCBO4PC63A300-10KA	6770				





WiNtrip Residual Current Circuit Breaker

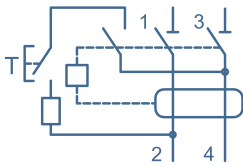

Test Button



Bi-connect Terminals

2 Pole, 30mA 10kA [HSN Code: 8536]

Current rating (Amps.)	Product Code	MRP (₹)	Std. Pkg. (Nos.)
10	CSRB2P10A30-10kA	3850	5
16	CSRB2P16A30-10kA	3850	
20	<input checked="" type="checkbox"/> CSRB2P20A30-10kA	3850	
25	CSRB2P25A30-10kA	3960	
32	CSRB2P32A30-10kA	4060	
40	CSRB2P40A30-10kA	4090	
63	CSRB2P63A30-10kA	5450	
80	<input checked="" type="checkbox"/> CSRB2P80A30-10kA	8140	
100	<input checked="" type="checkbox"/> CSRB2P100A30-10kA	8180	

2 Pole, 100mA 10kA [HSN Code: 8536]

Current rating (Amps.)	Product Code	MRP (₹)	Std. Pkg. (Nos.)
10	<input checked="" type="checkbox"/> CSRB2P10A100-10kA	3850	5
16	CSRB2P16A100-10kA	3850	
20	<input checked="" type="checkbox"/> CSRB2P20A100-10kA	3850	
25	CSRB2P25A100-10kA	3960	
32	CSRB2P32A100-10kA	4060	
40	CSRB2P40A100-10kA	4090	
63	CSRB2P63A100-10kA	5450	
80	CSRB2P80A100-10kA	8140	
100	<input checked="" type="checkbox"/> CSRB2P100A100-10kA	8180	

2 Pole, 300mA 10kA [HSN Code: 8536]

Current rating (Amps.)	Product Code	MRP (₹)	Std. Pkg. (Nos.)
10	CSRB2P10A300-10kA	3860	5
16	<input checked="" type="checkbox"/> CSRB2P16A300-10kA	3860	
20	CSRB2P20A300-10kA	3870	
25	CSRB2P25A300-10kA	4180	
32	<input checked="" type="checkbox"/> CSRB2P32A300-10kA	4220	
40	<input checked="" type="checkbox"/> CSRB2P40A300-10kA	4480	
63	<input checked="" type="checkbox"/> CSRB2P63A300-10kA	5610	
80	<input checked="" type="checkbox"/> CSRB2P80A300-10kA	8180	
100	CSRB2P100A300-10kA	8220	

Non Stockable item

WiNtrip Residual Current Circuit Breaker

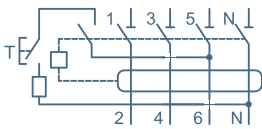

Test Button



Bi-connect Terminals

4 Pole, 30mA 10kA [HSN Code: 8536]

Current rating (Amps.)	Product Code	MRP (₹)	Std. Pkg. (Nos.)
10	☒CSR4P10A30-10kA	4790	4
16	CSR4P16A30-10kA	4810	
20	☒CSR4P20A30-10kA	4850	
25	CSR4P25A30-10kA	5090	
32	CSR4P32A30-10kA	5100	
40	CSR4P40A30-10kA	5220	
63	CSR4P63A30-10kA	5930	
80	CSR4P80A30-10kA	8960	
100	☒CSR4P100A30-10kA	9210	

4 Pole, 100mA 10kA [HSN Code: 8536]

Current rating (Amps.)	Product Code	MRP (₹)	Std. Pkg. (Nos.)
10	☒CSR4P10A100-10kA	4790	4
16	☒CSR4P16A100-10kA	4810	
20	CSR4P20A100-10kA	4850	
25	CSR4P25A100-10kA	5090	
32	CSR4P32A100-10kA	5100	
40	CSR4P40A100-10kA	5220	
63	CSR4P63A100-10kA	5930	
80	CSR4P80A100-10kA	8960	
100	CSR4P100A100-10kA	9210	

4 Pole, 300mA 10kA [HSN Code: 8536]

Current rating (Amps.)	Product Code	MRP (₹)	Std. Pkg. (Nos.)
10	☒CSR4P10A300-10kA	4810	4
16	☒CSR4P16A300-10kA	4840	
20	CSR4P20A300-10kA	4890	
25	☒CSR4P25A300-10kA	5330	
32	☒CSR4P32A300-10kA	5330	
40	CSR4P40A300-10kA	5560	
63	CSR4P63A300-10kA	5970	
80	☒CSR4P80A300-10kA	9030	
100	CSR4P100A300-10kA	9250	

NOTE:

1. MCB in bulk packing are available on request.
2. The industrial MCB will have non-retail (NR) suffix in their part codes.
3. For MCB technical Data sheet, Dimesion details etc. please refer product catalogue or contact nearest Branch Office.

☒ Non Stockable item

ACCL

Automatic Changeover with Current Limiter

- Complying to IEC 60947-6 & IEC 60947-3
- Utilization Category AC 32A
- Rating : Mains - 30A, DG - 0.5A~30A
- Individual LED for Mains & DG
- Quick Transfer Time
- Fault Annunciation
- Higher Electrical Life
- Low Blackout Time
- Din Rail Mounting
- Auto Reset Facility
- Can be used for New Installations as Well as for Retrofits



ACCL

[HSN Code: 8536]

Product Code	Mains Rating (Amps.)	Genset Rating (Amps.)	MRP (₹)
TCALSS005	30	0.5	4550
TCALSS010	30	1	4550
TCALSS015	30	1.5	4550
TCALSS025	30	2.5	4550
TCALSS030	30	3	4550
TCALSS040	30	4	4550
TCALSS050	30	5	4550
TCALSS060	30	6	4550
TCALSS080	30	8	4550
TCALSS090	30	9	4550
TCALSS100	30	10	4550
TCALSS150	30	15	4550
TCALSS200	30	20	4550
TCALSS250	30	25	4550
TCALSS300	30	30	4550

☒ Non Stockable item



Distribution Board

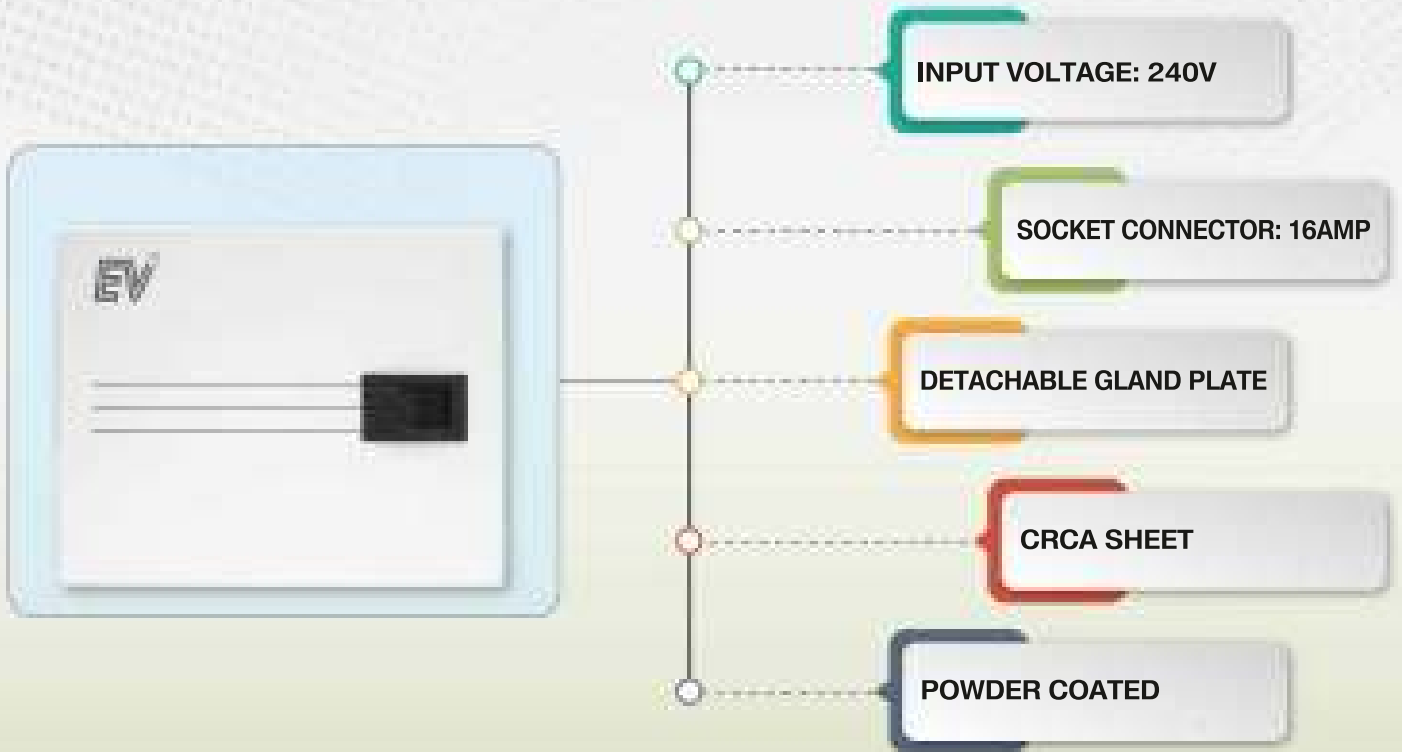

- Dedicated Charging Infrastructure
- Electric Utilities
- Efficient Power Distribution
- Car Parking

*For MRP & other details, please contact nearest branch office



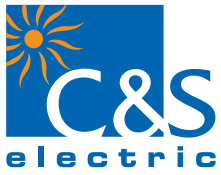

Epitome

Mivan Distribution Boards for Mivan Construction

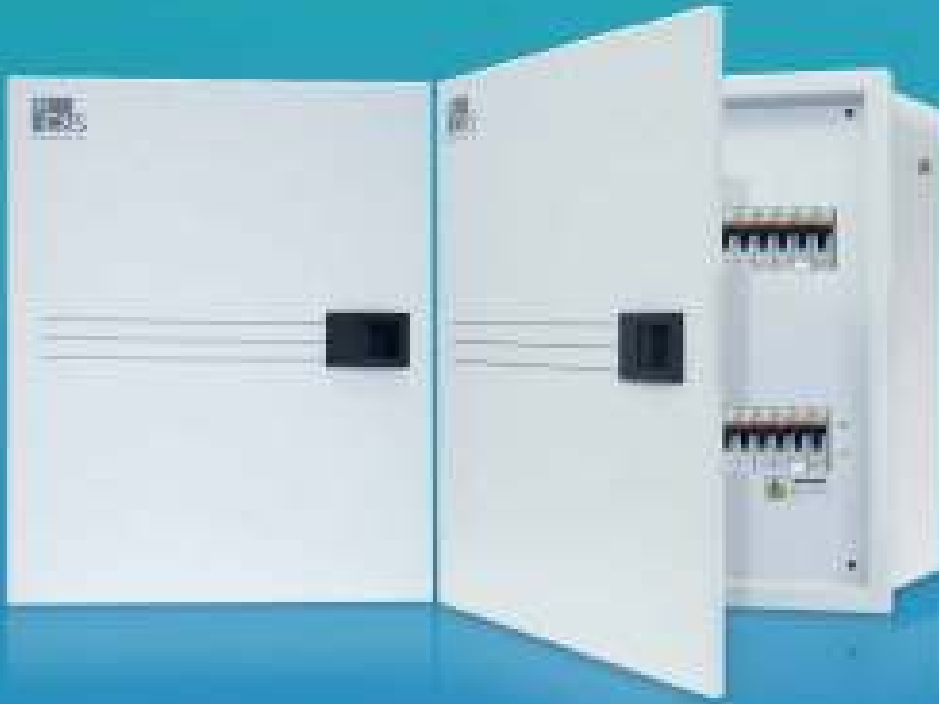

STRONG

SMART

SLEEK

- IP43 Version-SPN-TPN
- Increased Sheet Thickness
- Low Depth -75mm
- Strong Gland Plates
- Option for real time data monitoring

*For MRP & other details, please contact nearest branch office



for Residential & industrial application

- Heavy duty Gasket to inhibit the entry of foreign particles
- Choice of multiple incomers as MCB/Isolator/RCCB
- Adequate wiring space
- Also available with lock & key mechanism for safety
- Real time data monitoring & seamless IOT Integration option available

EPITOME IP43 Distribution Boards

[HSN Code: 8537]

Description	Product Code	No. of Modules (Incomer+Outgoing)	MRP (₹)
SPN Distribution Board			
SPN Double Door 04 Way IP43 DB	CSDBSPNPWXDD04	4	2540
SPN Double Door 06 Way IP43 DB	CSDBSPNPWXDD06	6	2980
SPN Double Door 08 Way IP43 DB	CSDBSPNPWXDD08	8	3210
SPN Double Door 10 Way IP43 DB	CSDBSPNPWXDD10	10	3870
SPN Double Door 12 Way IP43 DB	CSDBSPNPWXDD12	12	4070
SPN Double Door 16 Way IP43 DB	CSDBSPNPWXDD16	16	5180
SPN Double Door 20 Way IP43 DB	CSDBSPNPWXDD20	20	7000
TPN Distribution Board			
TPNH Double Door 04 Way IP43 DB	CSDBTPNHPWXDD04	8+12	6850
TPNH Double Door 06 Way IP43 DB	CSDBTPNHPWXDD06	8+18	8550
TPNH Double Door 08 Way IP43 DB	CSDBTPNHPWXDD08	8+24	10630
TPNH Double Door 12 Way IP43 DB	CSDBTPNHPWXDD12	8+36	14410
TPNH Double Door 16 Way IP43 DB	CSDBTPNHPWXDD16	8+48	18770

EPITOME IP43 Distribution Boards

[HSN Code: 8537]

Description	Product Code	No. of Modules (Incomer+Outgoing)	MRP (₹)
PPI Vertical Distribution Board			
4 Way Double Door	CSDBTPNVPIWXDD04	8+6+12	11290
6 Way Double Door	CSDBTPNVPIWXDD06	8+6+18	11820
8 Way Double Door	CSDBTPNVPIWXDD08	8+6+24	13560
12 Way Double Door	CSDBTPNVPIWXDD12	8+6+36	16810
PPI Horizontal Distribution Board			
4 Way Double Door	CSDBTPNHPIWXDD04	8+6+12	9810
6 Way Double Door	CSDBTPNHPIWXDD06	8+6+18	11070
8 Way Double Door	CSDBTPNHPIWXDD08	8+6+24	12600
12 Way Double Door	CSDBTPNHPIWXDD12	8+6+36	15790
Description	Product Code	No. of Modules (Incomer+Outgoing)	MRP (₹)
VTNP Distribution Board (with provision for MCCB Winbreak1 as incomer & Wintrip2 MCB as outgoing)			
DB MCCB AS I/C 125A DD04 Way	CSDBMCCB125PWXDD04S	MCCB+12	17780
DB MCCB AS I/C 125A DD06 Way	CSDBMCCB125PWXDD06S	MCCB+18	19230
DB MCCB AS I/C 125A DD08 Way	CSDBMCCB125PWXDD08S	MCCB+24	20020
DB MCCB AS I/C 125A DD12 Way	CSDBMCCB125PWXDD12S	MCCB+36	27090
DB MCCB AS I/C 250A DD04 Way	CSDBMCCB250PWXDD04S	MCCB+12	21340
DB MCCB AS I/C 250A DD06 Way	CSDBMCCB250PWXDD06S	MCCB+18	24540
DB MCCB AS I/C 250A DD08 Way	CSDBMCCB250PWXDD08S	MCCB+24	27780
DB MCCB AS I/C 250A DD12 Way	CSDBMCCB250PWXDD12S	MCCB+36	34720
Description	Product Code	No. of Modules (Incomer+Outgoing)	MRP (₹)
VTNP Distribution Board (with Wintrip2 MCB as Incoming & Outgoing)			
TPNV Double Door 04 Way IP43 DB	CSDBTPNVMCBWXDD04	8+12	12090
TPNV Double Door 06 Way IP43 DB	CSDBTPNVMCBWXDD06	8+18	14260
TPNV Double Door 08 Way IP43 DB	CSDBTPNVMCBWXDD08	8+24	16490
TPNV Double Door 12 Way IP43 DB	CSDBTPNVMCBWXDD12	8+36	21030

EPIC Distribution Board

[HSN Code: 8537]

Description	Product Code	Total Modules	MRP (₹)
SPN Distribution Board			
04 Way SPN Single Door	CSDBSPNPESD04	4	1210
06 Way SPN Single Door	CSDBSPNPESD06	6	1310
08 Way SPN Single Door	CSDBSPNPESD08	8	1550
12 Way SPN Single Door	CSDBSPNPESD12	12	1980
16 Way SPN Single Door	CSDBSPNPESD16	16	2530
SPN Distribution Board			
04 Way SPN Double Door	CSDBSPNPEDD04	4	2010
06 Way SPN Double Door	CSDBSPNPEDD06	6	2170
08 Way SPN Double Door	CSDBSPNPEDD08	8	2510
10 Way SPN Double Door	CSDBSPNPEDD10	10	3040
12 Way SPN Double Door	CSDBSPNPEDD12	12	3310
16 Way SPN Double Door	CSDBSPNPEDD16	16	4110

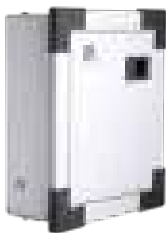

EPiC Distribution Board

[HSN Code: 8537]

Description	Product Code	Total Modules	MRP (₹)
TPN-Horizontal Distribution Board			
04 Way TPNH Single Door	CSDBTPNHPESD04	20	3810
06 Way TPNH Single Door	CSDBTPNHPESD06	26	4770
08 Way TPNH Single Door	CSDBTPNHPESD08	32	5590
12 Way TPNH Single Door	CSDBTPNHPESD12	44	7540
TPN-Horizontal Distribution Board			
04 Way TPNH Double Door	CSDBTPNHPEDD04	20	5510
06 Way TPNH Double Door	CSDBTPNHPEDD06	26	6790
08 Way TPNH Double Door	CSDBTPNHPEDD08	32	8130
12 Way TPNH Double Door	CSDBTPNHPEDD12	44	11070
TPN-Vertical Distribution Board			
04 Way TPNH Double Door	CSDBTPNVPECGDD04	20	10040
06 Way TPNH Double Door	CSDBTPNVPECGDD06	26	11830
08 Way TPNH Double Door	CSDBTPNVPECGDD08	32	13750
12 Way TPNH Double Door	CSDBTPNVPECGDD12	44	17520



EPiC-F Distribution Board

[HSN Code: 8537]

Description	Product Code	No. of Modules (Incomer+Outgoing)	MRP (₹)
SPN Distribution Board			
04 Way SPN Single Door	CSDBSPNPSD04	4	1250
06 Way SPN Single Door	CSDBSPNPSD06	6	1380
08 Way SPN Single Door	CSDBSPNPSD08	8	1590
12 Way SPN Single Door	CSDBSPNPSD12	12	2090
16 Way SPN Single Door	CSDBSPNPSD16	16	2720
SPN Distribution Board			
04 Way SPN Double Door	CSDBSPNPGDD04	4	2050
06 Way SPN Double Door	CSDBSPNPGDD06	6	2290
08 Way SPN Double Door	CSDBSPNPGDD08	8	2570
10 Way SPN Double Door	CSDBSPNPGDD10	10	3110
12 Way SPN Double Door	CSDBSPNPGDD12	12	3370
16 Way SPN Double Door	CSDBSPNPGDD16	16	4210
TPN-Horizontal Distribution Board			
04 Way TPNH Single Door	CSDBTPNHPSD04	8+12	4060
06 Way TPNH Single Door	CSDBTPNHPSD06	8+18	5050
08 Way TPNH Single Door	CSDBTPNHPSD08	8+24	5880
12 Way TPNH Single Door	CSDBTPNHPSD12	8+36	7940
TPN-Horizontal Distribution Board			
04 Way TPNH Double Door	CSDBTPNHPCGDD04	8+12	5500
06 Way TPNH Double Door	CSDBTPNHPCGDD06	8+18	6860
08 Way TPNH Double Door	CSDBTPNHPCGDD08	8+24	8340
12 Way TPNH Double Door	CSDBTPNHPCGDD12	8+36	11680
VTPN Distribution Board (with provision for MCCB Winbreak1 as incomer & Wintrip2 MCB as outgoing)			
DB MCCB AS I/C 100A DD04 Way	CSDBMCCB125PDD04S	MCCB+12	17180
DB MCCB AS I/C 100A DD08 Way	CSDBMCCB125PDD08S	MCCB+24	19360
DB MCCB AS I/C 100A DD12 Way	CSDBMCCB125PDD12S	MCCB+36	26750
DB MCCB AS I/C 250A DD04 Way	CSDBMCCB250PDD04S	MCCB+12	20620
DB MCCB AS I/C 250A DD08 Way	CSDBMCCB250PDD08S	MCCB+24	26850
DB MCCB AS I/C 250A DD12 Way	CSDBMCCB250PDD12S	MCCB+36	33550

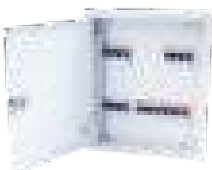

CSDBMCCB250PDD04S Non Stockable item



Distribution Board

Selection Table for MCCB as Incomer VTPN Distribution Boards



	Description	Product Code	Type/Breaking Capacity Ics=100%Icu	MCCB Rating
WINbreak 1 MCCB	CSE1M125ATM3P-*, CSE1M125ATM4P-*	CSDBMCCB125PDD04S	25kA, 36kA & 50kA	#FMU Release with rating lower than 63A ATM - 63A, 80A, 100A, 125A ETM - 40A, 63A, 100A, 125A
	CSE1NN125ATM3P-*, CSE1NN125ATM4P-*	CSDBMCCB125PDD08S		
	CSE1NN125ETM3P-*, CSE1NN125ETM4P-*	CSDBMCCB125PDD12S		
	CSE1S125ETM3P-*, CSE1S125ETM4P-*			
	CSE2M250ATM3P-*, CSE2M250A M4P-*	CSDBMCCB250PDD04S	25kA, 36kA & 50kA	ATM - 160A, 200A, 250V ETM - 160V, 200V, 250V
	CSE2NN250ATM3P-*, CSE2NN250ATM4P-*	CSDBMCCB250PDD08S		
CSE2NN250ETM3P-*, CSE2NN250ETM4P-*	CSDBMCCB250PDD12S			
CSE2SX250ETM3P-*, CSE2SX250ETM4P-*				
CSE2SX250ATM3P-*, CSE2SX250ATM4P-*				

NOTE: While Ordering, Replace "*" by current Rating.

#For lower ratings please contact nearest Branch Office.



SPN Winclass Distribution Board

[HSN Code: 8537]

Description	Product Code	No. of Modules (Incomer+Outgoing)	MRP (₹)
2+04 Way Double Door	CSDBSPNDD04S	2+04	2600
2+08 Way Double Door	CSDBSPNDD08S	2+08	3230
2+12 Way Double Door	CSDBSPNDD12S	2+12	4230
2+14 Way Double Door	CSDBSPNDD16S	2+14	5530

TPN Winclass Distribution Board

04 Way Double Door DB	CSDBTPNHDD04SN	4+12	6850
04 Way Double Door DB	CSDBTPNHDD04S	8+12	6920
06 Way Double Door DB	CSDBTPNHDD06S	8+18	8660
08 Way Double Door DB	CSDBTPNHDD08S	8+24	10910
12 Way Double Door DB	CSDBTPNHDD12S	8+36	15530
16 Way Double Door DB	CSDBTPNHDD16S	8+48	19590

VTPN Distribution Board (with provision for Wintrip2 MCB)

4 way Double Door	CSDBTPNVDD04S	8+12	17730
6 way Double Door	CSDBTPNVDD06S	8+18	20330
8 way Double Door	CSDBTPNVDD08S	8+24	22470
12 way Double Door	CSDBTPNVDD12S	8+36	30100

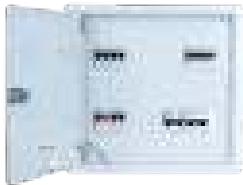

WiNtrip Distribution Board

Polycarbonate Cover Consumer Unit DB [HSN Code: 8537]

Description	Product Code	No. of Modules (Incomer+Outgoing)	MRP (₹)
SPN WC 06 Way SD With Acrylic Door	CSDBSPNSDCA06	6	2320
SPN WC 08 Way SD With Acrylic Door	CSDBSPNSDCA08	8	2600
SPN WC 12 Way SD With Acrylic Door	CSDBSPNSDCA12	12	3350
SPN WC 16 Way SD With Acrylic Door	CSDBSPNSDCA16	16	4270



Phase Selector Distribution Board - TPN Phase Selector DD DB for incorporating MCB / Isolator / RCCB, equipped with 3 Nos 63A Phase Selector Switches & 3 No Plano Switches [HSN Code: 8537]

Description	Product Code	MRP (₹)
4 Way DD with 63A Rotary Switch	CSDBPHSCDD04RS63	19950
6 Way DD with 63A Rotary Switch	CSDBPHSCDD06RS63	20420
8 Way DD with 63A Rotary Switch	CSDBPHSCDD08RS63	22530
12 Way DD with 63A Rotary Switch	<input checked="" type="checkbox"/> CSDBPHSCDD12RS63	24950
4 Way DD with 40A Rotary Switch	CSDBPHSCDD04RS40	19830
6 Way DD with 40A Rotary Switch	CSDBPHSCDD06RS40	20060
8 Way DD with 40A Rotary Switch	<input checked="" type="checkbox"/> CSDBPHSCDD08RS40	22310
12Way DD with 40A Rotary Switch	<input checked="" type="checkbox"/> CSDBPHSCDD12RS40	24530
4 Way DD without Rotary Switch	<input checked="" type="checkbox"/> CSDBPHSCDD04	17060
6 Way DD without Rotary Switch	<input checked="" type="checkbox"/> CSDBPHSCDD06	17480
8 Way DD without Rotary Switch	CSDBPHSCDD08	19240
12 Way DD without Rotary Switch	CSDBPHSCDD12	21980



7 Segment Distribution Board [HSN Code: 8537]

Description	Product Code	No. of Modules (Incomer+Outgoing)	MRP (₹)
7 Segment TPN DD DB With Provision for FP MCB / Isolator / RCCB as incomer, DP MCB / Isolator / RCCB as sub incomer and SP MCBs as outgoing	<input checked="" type="checkbox"/> CSDB7SEGDD04	8+12+12	15640
	CSDB7SEGDD06	8+12+18	17610
	<input checked="" type="checkbox"/> CSDB7SEGDD08	8+12+24	19670
	<input checked="" type="checkbox"/> CSDB7SEGDD12	8+12+36	24980

Price on request : Prewired Distribution Board fitted with Busbar, Terminal Block for incoming/outgoing phase neutral & Earth duly wired with Provision for ISO/RCCB/MCB as incomer and SP outgoing (without MCBs)

Non Stockable item

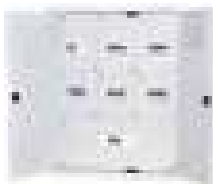



WiNtrip Distribution Board

Cable End Box

[HSN Code: 8537]

WiNclass Cable End Box

Description	Product Code	MRP (₹)
SPN Cable End Box		
SPN 4 Way	CSDBCBSPNDD04S	1190
SPN 8 Way	CSDBCBSPNDD08S	1470
SPN 12 Way	CSDBCBSPNDD12S	1730
SPN 16 Way	CSDBCBSPNDD16S	2080
TPNH Cable End Box		
TPNH 4 Way	CSDBCBTNHDD04SN	1550
TPNH 6 Way	CSDBCBTNHDD06S	1830
TPNH 8 Way	☒CSDBCBTNHDD08S	2140
TPNH 12 Way	☒CSDBCBTNHDD12S	2690
TPNH 16 Way	CSDBCBTNHDD16S	3210
VTPN MCB I/C Cable End box		
CABLE END BOX FOR CSDBTPNVDD04~12S WAY DB	CSDBCBTNPVDD	2610
Epic-F / Epic Cable End Box		
SPN Cable End Box		
SPN 4 Way	CSDBCBSPNPDD04	990
TPNH 6 Way	CSDBCBSPNPDD06	1100
SPN 8 Way	☒CSDBCBSPNPDD08	1240
SPN 12 Way	CSDBCBSPNPDD12	1540
SPN 16 Way	CSDBCBSPNPDD16	1880
TPNH Cable End Box		
TPNH 4 Way	CSDBCBTNPHPDD04	1600
TPNH 6 Way	CSDBCBTNPHPDD06	1840
TPNH 8 Way	☒CSDBCBTNPHPDD08	2100
TPNH 12 Way	CSDBCBTNPHPDD12	2680
EPiC TPNV Cable End Box		
CABLE END BOX FOR CSDBTPNPVEDD 04~12 WAY DB	CSDBCBTNPVEDD	2270
VTPN MCCB I/C Cable End Box		
CABLE END BOX FOR CSDBMCCB125PDD04~12S WAY DB	CSDBCMBCCBPDDDB	2690
PPI Kit		
PPI KIT TO CONVERT TPNHP/TPNHPE DD 04 TO DD 02 WAY	CSDBPPPIKT01	3180
PPI KIT TO CONVERT TPNHP/TPNHPE DD 06 TO DD 04 WAY	CSDBPPPIKT02	3580
PPI KIT TO CONVERT TPNHP/TPNHPE DD 08 TO DD 06 WAY	CSDBPPPIKT03	4020
PPI KIT TO CONVERT TPNHP/TPNHPE DD 12 TO DD 10 WAY	CSDBPPPIKT04	4830

WiNtrip Distribution Board

WiNtrip Plug and Socket DBs (without MCB)

Powder Coated Sheet Metal Deep Drawn DBs with Plug & Socket including insulated Neutral link, adjustable Din Rail and connecting links.

[HSN Code: 8537]



Description	Product Code	MRP (₹)	Std. Pkg. (No.s)
10Amp SPN	<input checked="" type="checkbox"/> CSDBPSSPN010	1810	12
20Amp SPN	CSDBPSSPN020	1810	12
20Amp SPN (SP Cutout)	CSDBPSSPN020SP	1810	12
20Amp TPN	CSDBPSTPN020	4380	6
30Amp TPN	CSDBPSTPN030	4810	6

WiNtrip Plug and Sockets (Metal Clad)

[HSN Code: 8537]



Description	Product Code	MRP (₹)	Std. Pkg. (No.s)
10Amp SPN Plug	CSDBPSPN010	370	36
10Amp SPN Socket	CSDBSSPN010	380	36
20Amp SPN Plug	CSDBPSPN020	390	36
20Amp SPN Socket	CSDBSSPN020	470	36
20Amp TPN Plug	CSDBPTPN020	480	36
20Amp TPN Socket	CSDBSTPN020	480	36
30Amp TPN Plug	CSDBPTPN030	750	36
30Amp TPN Socket	CSDBSTPN030	750	36

WiNtrip Metal Enclosures (with Din Rail)

For Mounting WiNtrip MCBs / RCCBs / Isolators

[HSN Code: 8537]



Description	Product Code	MRP (₹)	Std. Pkg. (No.s)
SP Enclosure	CSDBMCBESP	630	24
DP Enclosure	CSDBMCBEDP	630	24
TP Enclosure	CSDBMCBETP	740	12
FP Enclosure	CSDBMCBEFP	740	12

WiNtrip Plastic Enclosure without MCB

[HSN Code: 8537]

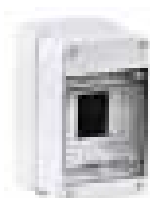

Description	Product Code	MRP (₹)
Plastic MCB Enclosure SP&DP/STD	CSDBMCBEPDP	250
Plastic MCB Enclosure TP&FP/STD	CSDBMCBEFPF	340

MCB Enclosure IP55

[HSN Code: 8537]

4 Pole Enclosure

Description	Product Code	MRP (₹)	Std. Pkg. (No.s)
MCB Enclosure IP55 04 Way	CSDBEP04	2500	1

Non Stockable item



elusio
SWITCHES
Born Green



© 2018 C&S

Stylish and eco-friendly.
30% more switch.
upto 3 times more switching.



FRONT MOUNT
& REMOVAL OPTION



SLEEK
DESIGN



UNBREAKABLE
DESIGNS



SMOOTH
TO TOUCH

Colors available in White, Elusio Green, Champagne, Dark Grey & Charcoal Black

Switches

Product Code	HSN Code	Description	Rating	Module	MRP (₹)			Std. Pkg. (Nos.)
					White	Colour	Elusio Green	
CE20113NR	85361010	6AX Switch SP 1 way	6AX	1M	131	172	198	20
CE20114NR	85361010	6AX Switch SP 1 way with Indicator	6AX	1M	170	195	225	
CE20123NR	85361010	6AX Switch SP 2 way	6AX	1M	187	212	244	
CE20568NR	85361010	10AX Switch SP 1 way	10AX	1M	151	198	228	
CE20569NR	85361010	10AX Switch SP 1 way with Indicator	10AX	1M	195	225	258	
CE20571NR	85361010	10AX Switch SP 2 way	10AX	1M	215	244	280	
CE20573NR	85361020	16AX Switch SP 1 way	16AX	1M	179	204	234	
CE20574NR	85361020	16AX Switch SP 1 way with Indicator	16AX	1M	235	252	290	
CE20578NR	85361020	16AX Switch SP 2 way	16AX	1M	263	288	331	
CE20580NR	85361020	20AX Switch SP 1 way	20AX	1M	206	234	269	
CE20581NR	85361020	20AX Switch SP 2 way	20AX	1M	302	331	380	
CE20584NR	85361020	20AX Switch SP 1 way with Indicator	20AX	1M	271	290	333	
CE20115NR	85361010	6AX Switch SP 1 way with Indicator	6AX	2M	221	236	272	10
CE20124NR	85361010	6AX Switch SP 2 way	6AX	2M	213	255	294	
CE20570NR	85361010	10AX Switch SP 1 way with Indicator	10AX	2M	254	272	313	
CE20572NR	85361010	10AX Switch SP 2 way	10AX	2M	245	293	338	
CE20575NR	85361020	16AX Switch SP 1 way with Indicator	16AX	2M	232	274	315	
CE20579NR	85361020	16AX Switch SP 2 way	16AX	2M	271	313	360	
CE20582NR	85361020	20AX Switch SP 1 way	20AX	2M	252	284	357	
CE20583NR	85361020	20AX Switch SP 2 way	20AX	2M	312	360	414	
CE20121NR	85361020	32A DP Switch with Indicator	32A	2M	646	837	962	

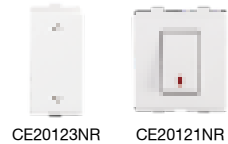

Bell Push Switches

Product Code	HSN Code	Description	Rating	Module	MRP (₹)			Std. Pkg. (Nos.)
					White	Colour	Elusio Green	
CE20509NR	85361010	6A Bell Push Switch	6A	1M	144	168	193	20
CE20508NR	85361010	6A Bell Push Switch with Indicator	6A	1M	172	197	227	
CE20510NR	85361010	6A Bell Push Switch	6A	2M	168	209	240	10
CE20511NR	85361010	6A Bell Push Switch with Indicator	6A	2M	197	238	274	

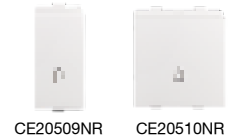

Blanking / Phase Indicator

Product Code	HSN Code	Description	Module	MRP (₹)			Std. Pkg. (Nos.)
				White	Colour	Elusio Green	
CE20056NR	85361010	Blanking Plate	1M	46	57	65	40
CE20631NR	85361010	Phase Indicator Red	1M	298	-	-	20



Fan Regulator / Dimmer

Product Code	HSN Code	Description	Rating	Module	MRP (₹)			Std. Pkg. (Nos.)
					White	Colour	Elusio Green	
CE20827NR	85361010	4 Step Fan Regulator	100W	1M	468	489	562	20
CE20826NR	85361010	5 Step Fan Regulator	100W	2M	599	646	743	10
CE20828NR	85361010	5 Step Fan Regulator	120W	2M	786	834	931	10
CE20804NR	85361010	Rotary Dimmer	300W	1M	649	697	801	20
CE20801NR	85361010	Rotary Dimmer	500W	2M	752	835	961	10



Sockets

Product Code	HSN Code	Description	Rating	Module	MRP (₹)			Std. Pkg. (Nos.)
					White	Colour	Elusio Green	
CE20370NR	85361020	6A 3 Pin Socket	6A	2M	184	301	347	10
CE20352NR	85361020	6/16A 3 Pin Socket	6/16A	2M	303	362	416	
CE20354NR	85361020	6/16A 3 Pin Socket- Projected	6/16A	2M	320	380	437	10
*CE20358NR	85361020	13A Universal Socket	13A	2M	184	301	347	

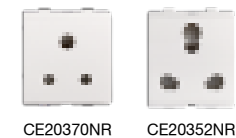

*Material available till stock last.

NOTE: For ordering color accessories suffix CB for Charcol Black, DG for Dark Grey, CZ for Champagne, JG for Elusio Green e.g. for ordering one module Charcol Black plate, the code would be CE25801CB

TV / Telephone / Computer / HDMI / VGA / USB / Night Lamp / Skirt Light

Product Code	HSN Code	Description	Rating	Module	MRP (₹)			Std. Pkg. (Nos.)
					White	Colour	Elusio Green	
CE20228NR	85361010	TV Socket		1M	112	135	155	20
CE20251NR	85361010	RJ 11 Telephone Socket		1M	106	130	149	
CE20272NR	85361010	RJ 45 Cat 6 Computer Socket	Cat 6	1M	1072	1113	1280	
CE20273NR	85361010	RJ 45 Cat 6a Computer Socket	Cat6a	1M	2105	2141	2462	10
CE20276NR	85361010	HDMI Socket		1M	1289	1481	1703	
CE20277NR	85361010	VGA Socket		1M	1284	1418	1631	
CE20275NR	85044030	USB Charger Socket (Fast Charging)	2.1A, A type	1M	1164	1474	1696	20
CE20278NR	85044030	USB Charger Socket (Power Delivery)	18W C type	1M	3100	3500	3700	
CE20633NR	94051090	Night Lamp		2M	473	515	592	10
CE20632NR	94051090	Skirt Light with LED		2M	654	714	821	



CE20364NR

Single Phase Motor Starter

Product Code	HSN Code	Description	Rating	Module	MRP (₹)			Std. Pkg. (Nos.)
					White	Colour	Elusio Green	
CE20364NR	85361020	Motor Starter 16A	16A	2M	705	762	877	10
CE20366NR	85361020	Motor Starter 25A	25A	2M	705	762	877	

Hospitality Range

Product Code	HSN Code	Description	Module	MRP (₹)			Std. Pkg. (Nos.)
				White	Colour	Elusio Green	
CE20611NR	85361010	DND/CMR internal unit	1M	384	410	471	10
CE20610NR	85361010	DND/CMR external unit	1M	615	629	723	
CE20609NR	85361010	DND/MMR Indicator	1M	440	473	544	20
CE20116NR	85361010	6AX Switch SP 1 way MMR	1M	168	173	200	
CE20125NR	85361010	6AX Switch SP 2 way DND	1M	221	226	259	
CE20636NR	85361010	Buzzer	1M	635	714	821	
CE20825NR	85361010	16A Electronic Key Card Switch	2M	13388	15225	17509	3



CE20825NR

Modular - Miniature Circuit Breakers

Product Code	HSN Code	Description	Rating	Module	MRP (₹)			Std. Pkg. (Nos.)
					White	Colour	Elusio Green	
CE20431NR	85361010	MCB 6A Single Pole 4.5kA	6A, C Curve	1M	406	442	508	12
CE20432NR	85361010	MCB 10A Single Pole 4.5kA	10A, C Curve	1M	406	442	508	
CE20433NR	85361010	MCB 16A Single Pole 4.5kA	16A, C Curve	1M	406	442	508	
CE20437NR	85361010	MCB 20A Single Pole 4.5kA	20A, C Curve	1M	406	442	508	
CE20435NR	85361010	MCB 25A Single Pole 4.5kA	25A, C Curve	1M	406	442	508	
CE20436NR	85361010	MCB 32A Single Pole 4.5kA	32A, C Curve	1M	406	442	508	
CE20438NR	85361010	MCB 6A Double Pole 4.5kA	6A, C Curve	2M	835	893	1026	6
CE20439NR	85361010	MCB 10A Double Pole 4.5kA	10A, C Curve	2M	835	893	1026	
CE20440NR	85361010	MCB 16A Double Pole 4.5kA	16A, C Curve	2M	835	893	1026	
CE20441NR	85361010	MCB 20A Double Pole 4.5kA	20A, C Curve	2M	835	893	1026	
CE20442NR	85361010	MCB 25A Double Pole 4.5kA	25A, C Curve	2M	835	893	1026	
CE20443NR	85361010	MCB 32A Double Pole 4.5kA	32A, C Curve	2M	835	893	1026	

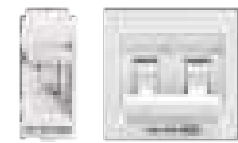

CE20436NR CE20440NR

Cover Plate with Support Plate

Product Code	HSN Code	Description	Module	MRP (₹)			Std. Pkg. (Nos.)
				White	Colour	Elusio Green	
CE25801WHNR	85381010	Cover & Support Plate	1M	119	239	275	10
CE25802WHNR	85381010	Cover & Support Plate	2M	123	234	269	
CE25803WHNR	85381010	Cover & Support Plate	3M	153	295	339	
CE25804WHNR	85381010	Cover & Support Plate	4M	181	352	405	
CE25806WHNR	85381010	Cover & Support Plate	6M	251	553	635	
CE25808WHNR	85381010	Cover & Support Plate-Horizontal	8M	307	621	714	
CE25809WHNR	85381010	Cover & Support Plate-Vertical	8MV	316	630	725	
CE25812WHNR	85381010	Cover & Support Plate	12M	440	900	960	
CE25816WHNR	85381010	Cover & Support Plate	16M	554	980	1040	
CE25818WHNR	85381010	Cover & Support Plate	18M	600	1250	1315	



CE25803WHNR

NOTE: For ordering color accessories suffix CB for Charcol Black, DG for Dark Grey, CZ for Champagne, JG for Elusio Green e.g. for ordering one module Charcol Black plate, the code would be CE25801CB



YOUR SAFETY MATTERS US

C&S Primo Plus Antibacterial Switches protects from Germs & Bacterial Infections.



Primo Plus SWITCHES

- Available with Anti Bacterial features*
- Sleek design, compatible with PRIMO range of switches
- Highly aesthetic break free design
- Compatible to market boxes
- High gloss design
- Designed with front mounting and removable feature
- Ease of mounting
- Available in 1M - 18M

DIVINO SWITCHES

Primo Plus SWITCHES

COMBI WEATHER PROOF ENCLOSURES

primo SWITCHES

bridgg SWITCHES



Modular Switches | DIVINO

Switches

Product Code - Pure White / Grey	HSN Code	Description	Type	No. of Modules	MRP (₹)	Std. Pkg. (Nos.)
One-Way Switches						
CG20113PWNR / CG23113NR	85361010	1P-6A	General	1	117	20
CG20114PWNR / CG23114NR	85361010	1P-6A	Luminous	1	165	
CG20573PWNR / CG23573NR	85361020	1P-16A	General	1	190	
CG20574PWNR / CG23574NR	85361020	1P-16A	Luminous	1	218	
CG20117PWNR / CG23117NR	85361020	1P-25A	General	1	246	
CG20118PWNR / CG23118NR	85361020	1P-25A	Luminous	1	301	
CG20120PWNR / CG23120NR	85361020	2P-32A	Luminous	2	444	10
Two-Way Switches						
CG20123PWNR / CG23123NR	85361010	1P-6A	General	1	161	20
CG20578PWNR / CG23578NR	85361020	1P-16A	General	1	237	

Product Code - Pure White / Grey	HSN Code	Description	Type	No. of Modules	MRP (₹)	Std. Pkg. (Nos.)
Bell Push Switches						
CG20508PWNR / CG23508NR	85361010	1P-6A	Luminous	1	209	20
CG20509PWNR / CG23509NR	85361010	1P-6A	With Symbol	1	165	

Product Code - Pure White / Grey	HSN Code	Description	Type	No. of Modules	MRP (₹)	Std. Pkg. (Nos.)
Blanking Modules						
CG20056PWNR / CG23056NR	85381010	1 Gang	-	1	38	40
CG20073PWNR / CG23073NR	85381010	2 Gang	-	2	66	20

Product Code - Pure White / Grey	HSN Code	Description	Type	No. of Modules	MRP (₹)	Std. Pkg. (Nos.)
Neon Indicators						
CG20634PWNR / CG23634NR	85361010	Red Color	-	1	109	20

Fan Regulator / Dimmer

Product Code - Pure White / Grey	HSN Code	Description	Type	No. of Modules	MRP (₹)	Std. Pkg. (Nos.)
Fan Regulator						
CG20826PWNR / CG23826NR	85361010	5 Step (100W)	Rotary	2	507	10
CG20827PWNR / CG23827NR	85361010	4 Step (100W)	Rotary	1	403	20

Product Code - Pure White / Grey	HSN Code	Description	Type	No. of Modules	MRP (₹)	Std. Pkg. (Nos.)
Dimmer						
CG20801PWNR / CG23801NR	85361010	500W	Rotary (Stepless)	2	503	10
CG20804PWNR / CG23804NR	85361010	300W	Rotary (Stepless)	1	444	20

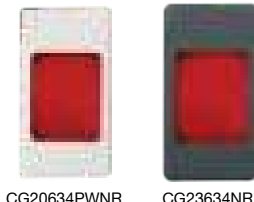

Socket

Product Code - Pure White / Grey	HSN Code	Description	For Plug Pin	No. of Modules	MRP (₹)	Std. Pkg. (Nos.)
Sockets With Safety Shutters						
CG20370PWNR / CG23370NR	85361010	6A Socket 3 Pin (Flushed)	Round	2	158	10
CG20354PWNR / CG23354NR	85361020	6/16A Twin Socket 3 Pin (Flushed)	Round	3	302	6
CG20352PWNR / CG23352NR	85361020	6/16A Twin Socket 3 Pin (Projected)	Round	2	288	10



CG20370PWNR CG23370NR



CG20251PWNR CG23251NR

Product Code - Pure White / Grey	HSN Code	Description	Nos. Pairs	For Plug Pin	No. of Modules	MRP (₹)	Std. Pkg. (Nos.)
Telephone / Computer / TV Socket							
CG20251PWNR / CG23251NR	85361010	RJ11	2	Twisted pair	1	132	20
CG20228PWNR / CG23228NR	85361010	TV Socket	-	-		125	
CG20272PWNR / CG23272NR	85361010	RJ45 CAT6	4	UTP		604	
CG20273PWNR / CG23273NR	85361010	RJ45 CAT6a		UTP		1328	

Buzzer

CG20636PWNR / CG23636NR	85361010	Buzzer	1	611	20
-------------------------	----------	--------	---	-----	----



CG20636PWNR



CG20275PWNR

USB Charger Socket

Product Code - Pure White / Grey	HSN Code	Description	No. of Modules	MRP (₹)	Std. Pkg. (Nos.)
CG20275PWNR / CG23275NR	85044030	USB Charger Socket 2.1A (Fast Charging)	1	1032	20

Hospitality Range

Product Code - Pure White / Grey	HSN Code	Description	No. of Modules	MRP (₹)	Std. Pkg. (Nos.)
Energy Key Tag					
CG20815PWNR / CG23815NR	85361020	1P-25A, 230V-Energy Key Switch With Tag	2	664	1
CG20434PWNR / CG23434NR	85361010	Tag For Energy Key Tag		137	10

Application activation of functions service inside hotel rooms (e.g.m light, air-conditioner, minibar) when the room is occupied (with badge inserted)

Do Not Disturb

CG20609PWNR / CG23609NR	85361010	Indicator	1	120	20
CG20124PWNR / CG23124NR	85361010	6A-230V, IW, SP Luminous Switch		170	
CG20612PWNR / CG23612NR	85361010	Unit (Indicator+Switch)	1+1	285	10

Room Occupied

CG20610PWNR / CG23610NR	85361010	Indicator	1	120	20
CG20125PWNR / CG23125NR	85361010	6A-230V, IW, SP Luminous Switch		170	
CG20613PWNR / CG23613NR	85361010	Unit (Indicator+Switch)	1+1	285	10

Make My Room

CG20611PWNR / CG23611NR	85361010	Indicator	1	120	20
CG20126PWNR / CG23126NR	85361010	6A-230V, IW, SP Luminous Switch		170	
CG20614PWNR / CG23614NR	85361010	Unit (Indicator+Switch)	1+1	285	10

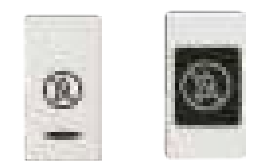

CG20124PWNR CG23609NR



CG20125PWNR CG23610NR



CG20126PWNR CG23611NR



Modular Switches | DIVINO

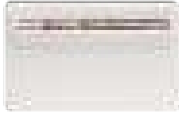

CG20825PWNR



CG20632NR



CG20436PWNR



CG20443PWNR



CG26401PWNR



CG20362PWNR



CG25703PWNR



CG25803PWNR

Product Code - Pure White / Grey	HSN Code	Description	No. of Modules	MRP (₹)	Std. Pkg. (Nos.)
Time Delay Electronic Switch (Card Operated)					
CG20825PWNR / CG23825NR	85361020	25A	3	1481	6

Foot Lamp					
CG20631NR	94051090	230V-LED Yellow Night Lamp	3	414	6
CG20632NR	94051090	230V-LED Blue Night Lamp			
CG20633NR	94051090	230V-LED White Night Lamp			

Modular Miniature Case Circuit Breaker - WIntrip 'S'

Product Code - Pure White	HSN Code	Description	No. of Modules	MRP (₹)	Std. Pkg. (Nos.)
Single Pole					
CG20431PWNR	85361010	6A Single Pole 4.5kA - Tripping Curve 'C'	1	235	12
CG20432PWNR	85361010	10A Single Pole 4.5kA - Tripping Curve 'C'			
CG20433PWNR	85361020	16A Single Pole 4.5kA - Tripping Curve 'C'			
CG20437PWNR	85361020	20A Single Pole 4.5kA - Tripping Curve 'C'			
CG20435PWNR	85361020	25A Single Pole 4.5kA - Tripping Curve 'C'			
CG20436PWNR	85361020	32A Single Pole 4.5kA - Tripping Curve 'C'			

Double Pole					
CG20438PWNR	85361010	6A Double Pole 4.5kA - Tripping Curve 'C'	2	560	6
CG20439PWNR	85361010	10A Double Pole 4.5kA - Tripping Curve 'C'			
CG20440PWNR	85361020	16A Double Pole 4.5kA - Tripping Curve 'C'			
CG20441PWNR	85361020	20A Double Pole 4.5kA - Tripping Curve 'C'			
CG20442PWNR	85361020	25A Double Pole 4.5kA - Tripping Curve 'C'			
CG20443PWNR	85361020	32A Double Pole 4.5kA - Tripping Curve 'C'			

Power Unit

Product Code - Pure White	HSN Code	Description	MRP (₹)	Std. Pkg. (Nos.)
Power Unit with Metal Box				
CG26401PWNR	85371000	16Amp Power Unit	1027	1
Power Unit with PVC				
CG26404PWNR	85371000	16Amp Power Unit	895	1

Single Phase Motor Starter

Product Code - Pure White / Grey	HSN Code	Description	No. of Modules	MRP (₹)	Std. Pkg. (Nos.)
CG20362PWNR / CG23362NR	85361020	Motor Starter 16A	2	494	10
CG20364PWNR / CG23364NR	85361020	Motor Starter 25A	2	628	

Pure White Cover Plates With Support Plate

Product Code - Vera / Virna	HSN Code	Description	MRP (₹)	Std. Pkg. (Nos.)
CG25701PWNR / CG25801PWNR	85381010	1 Module Plate	135	10
CG25702PWNR / CG25802PWNR	85381010	2 Module Plate		
CG25703PWNR / CG25803PWNR	85381010	3 Module Plate		
CG25704PWNR / CG25804PWNR	85381010	4 Module Plate		
CG25706PWNR / CG25806PWNR	85381010	6 Module Plate	289	5
CG25708PWNR / CG25808PWNR	85381010	8 Module Plate - Vertical		
CG25709PWNR / CG25809PWNR	85381010	8 Module Plate - Horizontal		
CG25712PWNR / CG25812PWNR	85381010	12 Module Plate		
CG25718PWNR / CG25818PWNR	85381010	18 Module Plate	709	

Glossy Grey Cover Plates With Support Plate

Product Code Vera / Virna	HSN Code	Description	MRP (₹)	Std. Pkg. (Nos.)
CG25701GRNR / CG25801GRNR	85381010	1 Module Plate	194	10
CG25702GRNR / CG25802GRNR	85381010	2 Module Plate		
CG25703GRNR / CG25803GRNR	85381010	3 Module Plate		
CG25704GRNR / CG25804GRNR	85381010	4 Module Plate		
CG25706GRNR / CG25806GRNR	85381010	6 Module Plate	418	5
CG25708GRNR / CG25808GRNR	85381010	8 Module Plate - Vertical		
CG25709GRNR / CG25809GRNR	85381010	8 Module Plate - Horizontal		
CG25712GRNR / CG25812GRNR	85381010	12 Module Plate		
CG25718GRNR / CG25818GRNR	85381010	18 Module Plate	874	

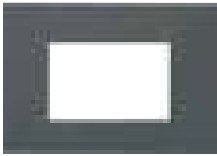

CG25803GRNR

Cover Plates With Support Plate

Product Code Vera / Virna	HSN Code	Description	MRP (₹)	Std. Pkg. (Nos.)
Cadet Grey / Black Olive / Argent Grey / Charcol Black / Arsenic Black / Champagne / Candy Red / Coral Red / British Green Plates				
CG25701NR / CG25801NR	85381010	1 Module Plate	292	10
CG25702NR / CG25802NR	85381010	2 Module Plate		
CG25703NR / CG25803NR	85381010	3 Module Plate		
CG25704NR / CG25804NR	85381010	4 Module Plate		
CG25706NR / CG25806NR	85381010	6 Module Plate	647	5
CG25708NR / CG25808NR	85381010	8 Module - Vertical		
CG25709NR / CG25809NR	85381010	8 Module - Horizontal		
CG25712NR / CG25812NR	85381010	12 Module Plate		
CG25718NR / CG25818NR	85381010	18 Module Plate	1076	

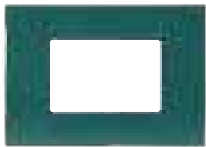

CG25803BGNR

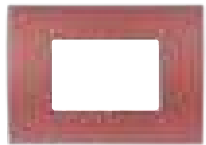

CG25803CORN

Please add codes CG for Cadet Grey, BO for Black Olive, AG for Argent Grey, CB for Charcol Black, AB for Arsenic Black, CH for Champagne, CAR for Candy Red, COR for Coral Red, BG for British Green Plates e.g. for ordering one module Vera Cadet Grey plate code would be CG25701CG

English Walnut & Burly Wood Cover Plates With Support Plate

Product Code Vera / Virna	HSN Code	Description	MRP (₹)	Std. Pkg. (Nos.)
CG25701NR / CG25801NR	85381010	1 Module Plate	364	10
CG25702NR / CG25802NR	85381010	2 Module Plate		
CG25703NR / CG25803NR	85381010	3 Module Plate		
CG25704NR / CG25804NR	85381010	4 Module Plate		
CG25706NR / CG25806NR	85381010	6 Module Plate	812	5
CG25708NR / CG25808NR	85381010	8 Module Plate - Vertical		
CG25709NR / CG25809NR	85381010	8 Module Plate - Horizontal		
CG25712NR / CG25812NR	85381010	12 Module Top Plate		
CG25718NR / CG25818NR	85381010	18 Module Plate	1205	

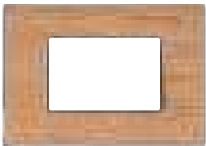

CG25703BWN



CG25803EWN

Please add codes EW for English Walnut and BW for Burly Wood e.g. for ordering one module Vera English Walnut plate code would be CG25701EW

Cover Plate Sizes (All dimensions in mm)

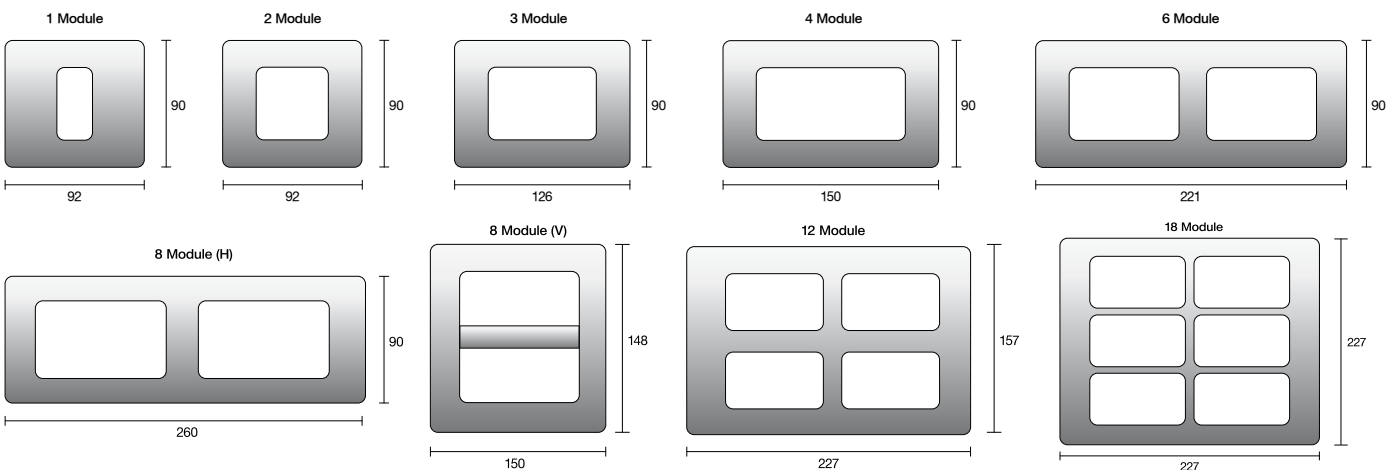

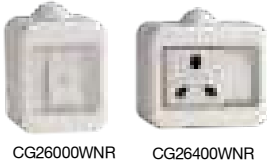

CG26000WNR CG26400WNR



CG24025WNR



CG26012WNR

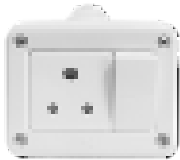

CG26020WNR

IP55 Enclosures

Product Code	HSN Code	Description	Configuration	MRP (₹)	Std. Pkg. (Nos.)
Watertight And Dust Proof Enclosures IP55-Surface Mounting					
CG26000WNR	85371000	Bell Push	1 Module	771	1
CG26400WNR	85371000	16A Switch, 6/16A Socket	3 Module	1313	
CG26016WNR	85371000	6A Switch	1 Module	712	10

IP55 Motor Starter

CG26018WNR	85381010	IP55 2M Enclosure With 16A Motor Starter		1284	10
CG26019WNR	85381010	IP55 2M Enclosure With 25A Motor Starter		1509	

Watertight Plates For Flush Mounting Installations IP55 (Compatible with 3M concealed box)

CG24025WNR	85381010	3 Gang		817	10
------------	----------	--------	--	-----	----

Product Code	HSN Code	Description	Configuration	External Dim. LxHxD (mm)	MRP (₹)	Std. Pkg. (Nos.)
--------------	----------	-------------	---------------	--------------------------	---------	------------------

Watertight Enclosures For Fixed Or Movable Applications

CG26010WNR	85381010	1 Gang	Module 1	80x64x59	551	10
CG26011WNR	85381010	2 Gang	Module 2	80x64x59	572	
CG26012WNR	85381010	3 Gang	Module 3	80x96x59	691	
CG26013WNR	85381010	4 Gang	Module 4x1	80x128x59	905	
CG26014WNR	85381010	8 Gang	Module 4x2	160x128x59	1546	5
CG26015WNR	85381010	12 Gang	Module 4x3	240x128x59	2037	3



IP40 Enclosures (Combined)

CG26020WNR	85381010	6A Switch, 6A Socket		357	10
CG26021WNR	85381010	16A Switch, 16A Protected Socket		410	

Accessories



CG28017NR



CG28020NR

Plug Top

Product Code	HSN Code	Description	MRP (₹)	Std. Pkg. (Nos.)
CG28014NR	85361010	6A Plug Top	75	10
CG28015NR	85361020	16A Plug Top	111	
CG28017NR	85361020	16A Plug Top with Indicator	119	

Multi Plug Socket

Product Code	HSN Code	Description	MRP (₹)	Std. Pkg. (Nos.)
CG28020NR	85361010	6A Multi Plug Socket	101	10

Power Extension & Door Bell

Product Code	HSN Code	Description	MRP (₹)	Std. Pkg. (Nos.)
ACEXB001NR	85381010	4 Universal Socket with 1 Master Switch with 1.5m wire	755	1
ACEXB002NR	85381010	4 Universal Socket with 4 Switches with 1.5m wire	765	
ACEXB003NR	85381010	4 Universal Socket with 1 Master Switch, 1 Thermal Switch with 1.5m wire	734	
ACEXB004NR	85381010	4 Universal Socket with 1 Master Switch with 3m wire	1000	
ACEXB005NR	85381010	4 Universal Socket with 4 Switches with 3m wire	1020	
ACEXB006NR	85381010	4 Universal Socket with 1 Master Switch, 1 Thermal Switch with 3m wire	984	
ACEXB007NR	85381010	4 Universal Socket with 1 Master Switch with 5m wire	1224	
ACEXB008NR	85381010	4 Universal Socket with 4 Switches with 5m wire	1260	
ACEXB009NR	85381010	4 Universal Socket with 1 Master Switch, 1 Thermal Switch with 5m wire	1204	
ACDB001NR	85381010	Door Bell - Jewell (Ding Dong Sound)	418	
ACDB002NR	85381010	Door Bell - Curvy (Ding Dong Sound)		



ACEXB001NR



ACEXB002NR



ACEXB003NR



ACDB001NR

ACDB002NR



ACBHS001NR

ACBHA004NR



ACBHA005NR



ACBHS006NR



ACBHS008NR



ACBHS001BNR



ACCR001NR

Batten Holder

Product Code	HSN Code	Description	MRP (₹)	Std. Pkg. (Nos.)
ACBHS001NR	85381010	Straight Batten Holder (Plain)	60	20
ACBHA003NR	85381010	Angular Batten Holder (Plain)		
ACBHS002NR	85381010	Straight Batten Holder (Fancy)	72	
ACBHA004NR	85381010	Angular Batten Holder (Fancy)	84	
ACBHA005NR	85381010	Batten Holder common (2 in 1)	96	10
ACBHS006NR	85381010	Square Batten Holder (Plain)		
ACBHA007NR	85381010	Square angle Batten Holder (Plain)		
ACBHS008NR	85381010	Slim Batten Holder (Fancy)	105	
ACBHA009NR	85381010	Slim angle Batten Holder (Fancy)		

Batten Holder & Ceiling Rose

Product Code	HSN Code	Description	MRP (₹)	Std. Pkg. (Nos.)
ACBHS001BNR	85381010	Batten Holder Straight	41	20
ACBHA003BNR	85381010	Batten Holder Angular		
ACBHS002BNR	85381010	Batten Holder Straight Fancy	56	
ACBHA004BNR	85381010	Batten Holder Angular Fancy		

Ceiling Rose

Product Code	HSN Code	Description	MRP (₹)	Std. Pkg. (Nos.)
ACCR001NR	85381010	Ceiling rose	50	20

Surface Plastic Box

Product Code	HSN Code	Description	MRP (₹)	Std. Pkg. (Nos.)
ACSMB001NR	85381010	1 Module	75	10
ACSMB002NR	85381010	2 Module	75	
ACSMB003NR	85381010	3 Module	97	
ACSMB004NR	85381010	4 Module	104	
ACSMB006NR	85381010	6 Module	140	
ACSMB008NR	85381010	8 Module (Horizontal)	192	
ACSMB009NR	85381010	8 Module (Vertical)	192	
ACSMB012NR	85381010	12 Module	244	
ACSMB018NR	85381010	18 Module	273	5



A Piece of Art with Complete
Safety, Comfort & Aesthetics
for your Walls

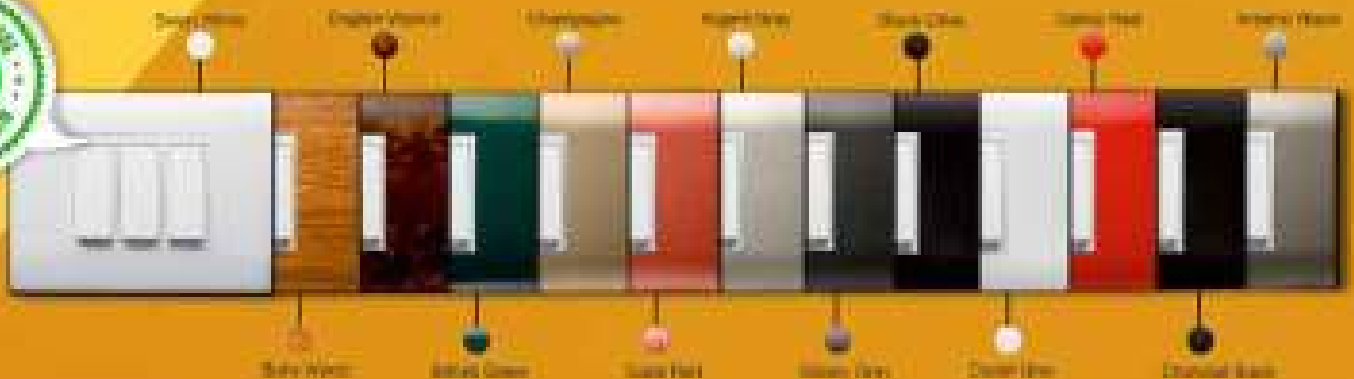
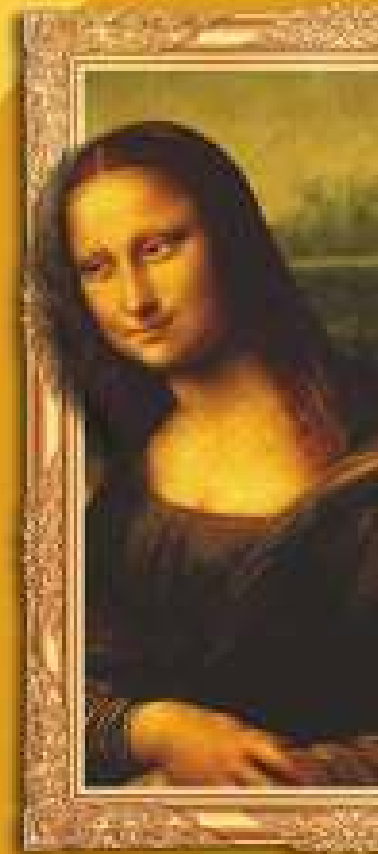
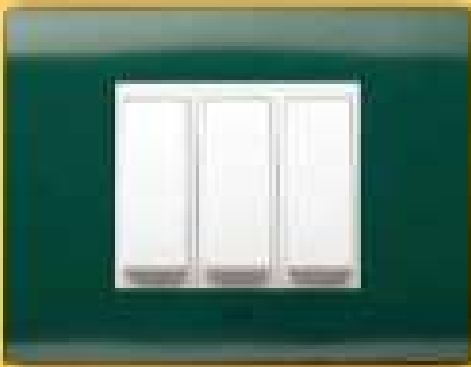

- Available in 1 Module to 18 Module*
- Sleek Design & Compatible with Primo Range of Switches
- Highly Aesthetic Break Free Design
- Compatible to Market Boxes
- Designed with Front Mount & Removal Option

* The Antibacterial feature are available only in White & Grey Top Plates & Accessories.

Switches

Product Code - Pure White / Grey	HSN Code	Description	Type	No. Modules	MRP (₹)	Std. Pkg. (Nos.)
-------------------------------------	----------	-------------	------	-------------	---------	---------------------

One-Way Switches

CS20113PNR / CS23113PNR	85361010	6A, 250V	General	1	98	20
CS20114PNR / CS23114PNR	85361010	6A, 250V	Luminous	1	130	
CS20115PNR / CS23115PNR	85361010	6A, 250V	Luminous	2	145	10
CS20573PNR / CS23573PNR	85361020	16A, 250V	General	1	160	20
CS20574PNR / CS23574PNR	85361020	16A, 250V	Luminous	1	190	
CS20575PNR / CS23575PNR	85361020	16A, 250V	Luminous	2	195	10
CS20117PNR / CS23117PNR	85361020	25A, 250V	General	1	212	20
CS20118PNR / CS23118PNR	85361020	25A, 250V	Luminous	1	235	
CS20119PNR / CS23119PNR	85361020	25A, 250V	General	2	238	10
CS20120PNR / CS23120PNR	85361020	25A, 250V	Luminous	2	256	

Two-Way Switches

CS20123PNR / CS23123PNR	85361010	6A, 250V	General	1	152	20
CS20124PNR / CS23124PNR	85361010	6A, 250V	General	2	160	10
CS20578PNR / CS23578PNR	85361020	16A, 250V	General	1	218	20
CS20579PNR / CS23579PNR	85361020	16A, 250V	General	2	241	10

Product Code - Pure White / Grey	HSN Code	Description	Type	No. Modules	MRP (₹)	Std. Pkg. (Nos.)
-------------------------------------	----------	-------------	------	-------------	---------	---------------------

Bell Push Switches

CS20509PNR / CS23509PNR	85361010	6A, Bell Push	General	1	135	20
CS20508PNR / CS23508PNR	85361010	6A, Bell Push	Luminous	1	156	
CS20510PNR / CS23510PNR	85361010	6A, Bell Push	General	2	162	10
CS20511PNR / CS23511PNR	85361010	6A, Bell Push	Luminous	2	165	

Blanking Module

CS20056PNR / CS23056PNR	85381010	1M Blank	General	1	28	40
-------------------------	----------	----------	---------	---	----	----

Product Code - Pure White / Grey	HSN Code	Description	No. Modules	MRP (₹)	Std. Pkg. (Nos.)
-------------------------------------	----------	-------------	-------------	---------	---------------------

Neon Indicator

CS20631PNR / CS23631PNR	85361010	Neon Indicator Red	1	100	20
-------------------------	----------	--------------------	---	-----	----

Product Code - Pure White / Grey	HSN Code	Description	No. Modules	MRP (₹)	Std. Pkg. (Nos.)
-------------------------------------	----------	-------------	-------------	---------	---------------------

Fan Regulator / Dimmer

CS20826PNR / CS23826PNR	85361010	5-Step Fan Regulator 100W	2	450	10
CS20828PNR / CS23828PNR	85361010	5 Step Fan Regulator 120 W	2	530	10
CS20827PNR / CS23827PNR	85361010	4-Step Fan Regulator 100W	1	370	20
CS20801PNR / CS23801PNR	85361010	Rotary Type Dimmer 500W	2	460	10
CS20804PNR / CS23804PNR	85361010	Rotary Type Dimmer 300W	1	338	20



CS20114PNR



CS20123PNR



CS20511PNR



CS20631NR



CS20801PNR



CS20370PNR



CS20636PNR

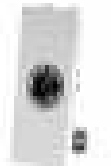

CS20228PNR



CS20251PNR



CS20275PNR

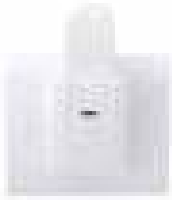

CS20816PNR

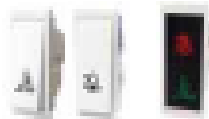

CS20611PNR CS20609PNR



CS20632PNR CS20633PNR

Product Code - Pure White / Grey	HSN Code	Description	No. Modules	MRP (₹)	Std. Pkg. (Nos.)
Sockets with Safety Shutters					
CS20370PNR / CS23370PNR	85361010	6A, 3 Pin	2	127	10
CS20352PNR / CS23352PNR	85361020	6/16A, 6 Pin	3	262	6
CS20354PNR / CS23354PNR	85361020	6/16A, Socket Projected	2	240	10

Buzzer

Product Code	HSN Code	Description	No. of Modules	MRP (₹)	Std. Pkg. (Nos.)
CS20636PNR / CS23636PNR	85044030	Buzzer	1	642	20

Product Code - Pure White / Grey	HSN Code	Description	No. Modules	MRP (₹)	Std. Pkg. (Nos.)
TV Socket / Flex Outlet					
CS20228PNR / CS23228PNR	85361010	TV Socket	1	115	20
CS20237PNR / CS23237PNR	85361010	Flex Outlet	1	85	

Product Code - Pure White / Grey	HSN Code	Description	No. Modules	MRP (₹)	Std. Pkg. (Nos.)
Telephone / Computer Socket					
CS20251PNR / CS23251PNR	85361010	RJ 11, Telephone Jack	1	128	20
CS20272PNR / CS23272PNR	85361010	RJ 45, Computer Jack CAT6	1	642	
CS20273PNR / CS23273PNR	85361010	RJ 45, Computer Jack CAT6a	1	1130	

USB Charger Socket

Product Code - Pure White / Grey	HSN Code	Description	No. of Modules	MRP (₹)	Std. Pkg. (Nos.)
CS20275PNR / CS23275PNR	85044030	USB Charger Socket 2.1A (Fast Charging)	1	995	20

Hospitality Range

Product Code - Pure White / Grey	HSN Code	Description	No. of Modules	MRP (₹)	Std. Pkg. (Nos.)
Energy Saving Switch					
CS20816PNR / CS23816PNR	85361020	25A, Energy Saving Switch With Key Tag & Indicator	2	586	1

APPLICATION: activation of functions and service inside hotel rooms (e.g. light, air-conditioner, minibar) when the room is occupied (with badge inserted).

DND/MMR Switch Units

CS20609PNR / CS23609PNR	85361010	Indicator	1	107	20
CS20610PNR / CS23610PNR	85361010	DND/MMR External Unit	1	265	10
CS20611PNR / CS23611PNR	85361010	DND/MMR Internal Unit	1+1	240	10

Skirt Light & Night Lamp

CS20632PNR / CS23632PNR	94051090	Skirt Light	2	445	10
CS20633PNR / CS23633PNR	94051090	Night Lamp	2	410	10

Primo Plus Power Unit with PVC

Product Code - Pure White	HSN Code	Description	No. of Modules	MRP (₹)	Std. Pkg. (Nos.)
CS26404PWNR	85371000	Power Unit Combo 16A MCB Protected Socket	4	850	1
CS26408PWNR	85371000	Power Unit Combo Heavy Duty with 25Amp MCB	4	1189	

Primo Plus Power Unit with Metal Enclosure

Product Code	HSN Code	Description	No. of Modules	MRP (₹)	Std. Pkg. (Nos.)
CS26401PNR	85371000	Power Unit Combo 16A MCB	4	1027	1
CS26407PWNR	85371000	Power Unit Combo Heavy Duty with 25Amp MCB	4	1194	

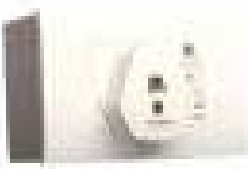

CS26404PWNR



CS25803WHNR

Product Code	HSN Code	Description	MRP (₹)	Std. Pkg. (Nos.)
--------------	----------	-------------	---------	------------------

Swan White (Cover Plates with Support Plate)

CS25801WHNR	85381010	1 Module Plate	118	10
CS25802WHNR	85381010	2 Module Plate		
CS25803WHNR	85381010	3 Module Plate	150	
CS25804WHNR	85381010	4 Module Plate	162	
CS25806WHNR	85381010	6 Module Plate	229	
CS25808WHNR	85381010	8 Module Plate (Horizontal)	291	
CS25809WHNR	85381010	8 Module Plate (Vertical)	291	5
CS25812WHNR	85381010	12 Module Plate	376	
CS25816WHNR	85381010	16 Module Plate	418	
CS25818WHNR	85381010	18 Module Plate	471	

Glossy Grey (Cover Plates with Support Plate)

CS25801GRNR	85381010	1 Module Plate	124	10
CS25802GRNR	85381010	2 Module Plate		
CS25803GRNR	85381010	3 Module Plate	158	
CS25804GRNR	85381010	4 Module Plate	170	
CS25806GRNR	85381010	6 Module Plate	241	
CS25808GRNR	85381010	8 Module Plate (Horizontal)	306	
CS25809GRNR	85381010	8 Module Plate (Vertical)	306	5
CS25812GRNR	85381010	12 Module Plate	395	
CS25816GRNR	85381010	16 Module Plate	450	
CS25818GRNR	85381010	18 Module Plate	495	



CS25803GRNR

Cover Plates with Support Plate

Product Code	HSN Code	Description	MRP (₹)	Std. Pkg. (Nos.)
--------------	----------	-------------	---------	------------------

Cadet Grey / Black Olive / Argent Grey / Charcol Black / Arsenic Black / Champagne / Candy Red / Corel Red / British Green Plates

CS25801NR	85381010	1 Module Plate	215	10
CS25802NR	85381010	2 Module Plate		
CS25803NR	85381010	3 Module Plate	254	
CS25804NR	85381010	4 Module Plate	285	
CS25806NR	85381010	6 Module Plate	431	
CS25808NR	85381010	8 Module - Horizontal	482	
CS25809NR	85381010	8 Module - Vertical	482	5
CS25812NR	85381010	12 Module Plate	624	
CS25816NR	85381010	16 Module Plate	666	
CS25818NR	85381010	18 Module Plate	807	



Please add codes CS for Cadet Grey, BO for Black Olive, AG for Argent Grey, CB for Charcol Black, AB for Arsenic Black, CH for Champagne, CAR for Candy Red, COR for Corel Red, BG for British Green Plates e.g. for ordering one module Cadet Grey plate code would be CS25801

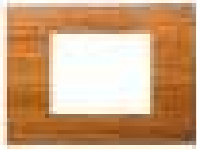

CS25803BWNR

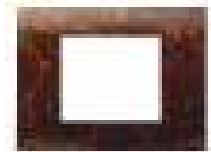

CS25803EWNR

English Walnut & Burly Wood Cover Plates with Support Plate

Product Code	HSN Code	Description	MRP (₹)	Std. Pkg. (Nos.)
CS25801NR	85381010	1 Module Plate	281	10
CS25802NR	85381010	2 Module Plate		
CS25803NR	85381010	3 Module Plate	308	
CS25804NR	85381010	4 Module Plate	324	
CS25806NR	85381010	6 Module Plate	554	
CS25808NR	85381010	8 Module Plate - Horizontal	639	
CS25809NR	85381010	8 Module Plate - Vertical	639	5
CS25812NR	85381010	12 Module Top Plate	828	
CS25816NR	85381010	16 Module Top Plate	925	
CS25818NR	85381010	18 Module Plate	984	

Please add codes EW for English Walnut and BW for Burly Wood e.g. for ordering one module English Walnut plate code would be CS25801EW

Fabricated Metal Boxes - Elusio, Divino, Primo Plus, Primo & Bridgg

Product Code	HSN Code	Description	Dimension LxHxD (mm)	MRP (₹)	Std. Pkg. (Nos.)
CG24271NR	85381010	1 Module Box	75 X 75 X 50	86	10
CG24271NR	85381010	2 Module Box	75 X 75 X 50		
CG24272NR	85381010	3 Module Box	100 X 75 X 50	102	
CG24273NR	85381010	4 Module Box	135 X 76 X 50	125	
CG24274NR	85381010	6 Module Box	210 X 75 X 50	176	5
CG24275NR	85381010	8 Module Box (4 +4)	134 X 140 X 52	204	
CG24276NR	85381010	8 Module Box (Horizontal)	232 X 79 X 52		
CG24277NR	85381010	12 Module Box	210 X 140 X 50	250	
CG24279NR	85381010	16 Module Box	210 X 140 X 60	314	7
CG24278NR	85381010	18 Module Box	210 X 210 X 56	353	5

* 10M Top Plate shall be fitted in 8M (4+4) Vertical Metal Box (i.e. CG 24 275)

* 5M Top Plate Shall be fitted in 4M Metal Box (i.e. CG 24 273)

* Deep Drawn Metal Boxes are available on request.



CG24272NR



CS20114NR



CS20123NR



CS20511NR



CS20801NR



CS20370NR



CS20228NR

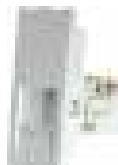

CS20251NR

Switches

Product Code - Pure White	HSN Code	Description	Type	No. Modules	MRP (₹)	Std. Pkg. (Nos.)
One-Way Switches						
CS20113NR	85361010	6A, 250V	General	1	87	20
CS20114NR	85361010	6A, 250V	Luminous	1	122	
CS20115NR	85361010	6A, 250V	Luminous	2	137	10
CS20573NR	85361020	16A, 250V	General	1	153	20
CS20574NR	85361020	16A, 250V	Luminous	1	182	
CS20575NR	85361020	16A, 250V	Luminous	2	188	10
CS20117NR	85361020	25A, 250V	General	1	204	20
CS20118NR	85361020	25A, 250V	Luminous	1	224	
CS20119NR	85361020	25A, 250V	General	2	230	10
CS20120NR	85361020	25A, 250V	Luminous	2	238	

Two-Way Switches

CS20123NR	85361010	6A, 250V	General	1	144	20
CS20124NR	85361010	6A, 250V	General	2	150	10
CS20578NR	85361020	16A, 250V	General	1	197	20
CS20579NR	85361020	16A, 250V	General	2	202	10

Product Code - Pure White	HSN Code	Description	Type	No. Modules	MRP (₹)	Std. Pkg. (Nos.)
---------------------------	----------	-------------	------	-------------	---------	------------------

Bell Push Switches

CS20509NR	85361010	6A, Bell Push	General	1	124	20
CS20508NR	85361010	6A, Bell Push	Luminous	1	144	
CS20510NR	85361010	6A, Bell Push	General	2	155	10
CS20511NR	85361010	6A, Bell Push	Luminous	2	159	

Blanking Module

CS20056NR	85381010	1M Blank	General	1	26	40
-----------	----------	----------	---------	---	----	----

Product Code - Pure White	HSN Code	Description	No. Modules	MRP (₹)	Std. Pkg. (Nos.)
---------------------------	----------	-------------	-------------	---------	------------------

Neon Indicator

CS20631NR	85361010	Neon Indicator Red	1	94	20
-----------	----------	--------------------	---	----	----

Product Code - Pure White	HSN Code	Description	No. Modules	MRP (₹)	Std. Pkg. (Nos.)
---------------------------	----------	-------------	-------------	---------	------------------

Fan Regulator / Dimmer

CS20826NR	85361010	5-Step Fan Regulator 100W	2	424	10
CS20828NR	85361010	5 Step Fan Regulator 120 W	2	508	10
CS20827NR	85361010	4-Step Fan Regulator 100W	1	353	20
CS20801NR	85361010	Rotary Type Dimmer 500W	2	447	10
CS20804NR	85361010	Rotary Type Dimmer 300W	1	322	20

Sockets with Safety Shutters

CS20370NR	85361010	6A, 3 Pin	2	120	10
CS20352NR	85361020	6/16A, 6 Pin	3	253	6
CS20354NR	85361020	6/16A, Socket Projected	2	229	10

Product Code - Pure White	HSN Code	Description	No. Modules	MRP (₹)	Std. Pkg. (Nos.)
---------------------------	----------	-------------	-------------	---------	------------------

TV Socket / Flex Outlet

CS20228NR	85361010	TV Socket	1	109	20
CS20237NR	85361010	Flex Outlet	1	79	

Product Code - Pure White	HSN Code	Description	No. Modules	MRP (₹)	Std. Pkg. (Nos.)
---------------------------	----------	-------------	-------------	---------	------------------

Telephone / Computer Socket

CS20251NR	85361010	RJ 11, Telephone Jack	1	121	20
CS20272NR	85361010	RJ 45, Computer Jack CAT6	1	612	
CS20273NR	85361010	RJ 45, Computer Jack CAT6a	1	1075	



CS20636NR



CS20275NR



CS20815NR

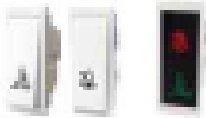

CS20611NR CS20609NR

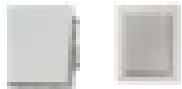

CS20632NR CS20633NR

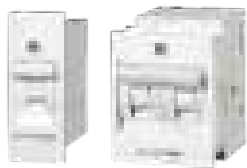

CS20431NR CS20443NR



CS26401WNR



CS20364NR

Buzzer

Product Code	HSN Code	Description	No. of Modules	MRP (₹)	Std. Pkg. (Nos.)
CS20636NR	85044030	Buzzer	1	613	20

USB Charger Socket

Product Code - Pure White	HSN Code	Description	No. of Modules	MRP (₹)	Std. Pkg. (Nos.)
CS20275NR	85044030	USB Charger Socket 2.1A (Fast Charging)	1	962	20

Hospitality Range

Product Code - Pure White	HSN Code	Description	No. of Modules	MRP (₹)	Std. Pkg. (Nos.)
---------------------------	----------	-------------	----------------	---------	------------------

Energy Saving Switch

CS20815NR	85361020	25A, Energy Saving Switch With Key Tag & Indicator	2	558	1
-----------	----------	--	---	-----	---

APPLICATION: activation of functions and service inside hotel rooms (e.g. light, air-conditioner, minibar) when the room is occupied (with badge inserted).

DND/MMR Switch Units

CS20610NR	85361010	DND/MMR External Unit	1+1	250	10
CS20611NR	85361010	DND/MMR Internal Unit	1+1	229	10
CS20609NR	85361010	Indicator	1	99	20

Skirt Light & Night Lamp

CS20632NR	94051090	Skirt Light	2	426	10
CS20633NR	94051090	Night Lamp	2	393	10

Modular Miniature Case Circuit Breaker - WiNtrip 'S'

Product Code - Pure White	HSN Code	Description	No. of Modules	MRP (₹)	Std. Pkg. (Nos.)
---------------------------	----------	-------------	----------------	---------	------------------

Single & Double Pole

CS20431NR	85361010	6A Single Pole 4.5kA - Tripping Curve 'C'	1	253	12
CS20432NR	85361010	10A Single Pole 4.5kA - Tripping Curve 'C'			
CS20433NR	85361020	16A Single Pole 4.5kA - Tripping Curve 'C'			
CS20437NR	85361020	20A Single Pole 4.5kA - Tripping Curve 'C'			
CS20435NR	85361020	25A Single Pole 4.5kA - Tripping Curve 'C'			
CS20436NR	85361020	32A Single Pole 4.5kA - Tripping Curve 'C'			
CS20438NR	85361010	6A Double Pole 4.5kA - Tripping Curve 'C'	2	582	6
CS20439NR	85361010	10A Double Pole 4.5kA - Tripping Curve 'C'			
CS20440NR	85361020	16A Double Pole 4.5kA - Tripping Curve 'C'			
CS20441NR	85361020	20A Double Pole 4.5kA - Tripping Curve 'C'			
CS20442NR	85361020	25A Double Pole 4.5kA - Tripping Curve 'C'	2		
CS20443NR	85361020	32A Double Pole 4.5kA - Tripping Curve 'C'			

Power Unit with Metal Box

Product Code - Pure White	HSN Code	Description	No. of Modules	MRP (₹)	Std. Pkg. (Nos.)
CS26401WNR	85371000	Power Unit Combo 16A MCB Protected Socket	4	846	1

Single Phase Motor Starter

Product Code	HSN Code	Description	MRP (₹)	Std. Pkg. (Nos.)
CS20364NR	85361020	Motor Starter 16A	732	10
CS20366NR	85361020	Motor Starter 25A		

Top Plates with Support Plate

Product Code - Pure White	HSN Code	Description	MRP (₹)	Std. Pkg. (Nos.)	
CS25701WHNR	85381010	1 Module Plate	90	10	
CS25702WHNR	85381010	2 Module Plate			
CS25703WHNR	85381010	3 Module Plate	141		
CS25704WHNR	85381010	4 Module Plate	147		
CS25705WHNR	85381010	5 Module Plate (Compatible with 4M Metal Box)			
CS25706WHNR	85381010	6 Module Plate	200		
CS25707WHNR	85381010	8 Module-Horizontal	265		
CS25709WHNR	85381010	8 Module Plate Horizontal (Compatible with 6M Metal Box)			
CS25710WHNR	85381010	10 Module-Vertical (Compatible With 8M (4+4) Metal Box)	265		5
CS25711WHNR	85381010	10 Module-Horizontal (Compatible With 8M (H) Metal Box)	265		10
CS25712WHNR	85381010	12 Module Plate	332	5	
CS25716WHNR	85381010	16 Module Plate (Compatible With 12M Metal Box)	418		
CS25718WHNR	85381010	18 Module Plate	433		

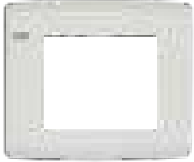

Red / Yellow/ Green/ Blue / Grey Plates

CS25701NR	85381010	1 Module Plate	102	10	
CS25702NR	85381010	2 Module Plate			
CS25703NR	85381010	3 Module Plate	148		
CS25704NR	85381010	4 Module Plate	154		
CS25705NR	85381010	5 Module Plate (Compatible With 4M Metal Box)			
CS25706NR	85381010	6 Module Plate	209		
CS25707NR	85381010	8 Module Horizontal	268		
CS25709NR	85381010	8 Module Plate Horizontal (Compatible with 6M Metal Box)			
CS25710NR	85381010	10 Module-Vertical (Compatible With 8M (4+4) Metal Box)	268		5
CS25711NR	85381010	10 Module-Horizontal (Compatible With 8M (H) Metal Box)	268		10
CS25712NR	85381010	12 Module Plate	358	5	
CS25716NR	85381010	16 Module Plate (Compatible With 12M Metal Box)	436		
CS25718NR	85381010	18 Module Plate	500		

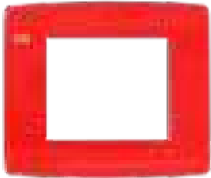

Please add following to codes for color selection GR for Grey / RD for RED / YL for Yellow / BL for Blue/ GN for Green e.g. for ordering one module red plate code would be CS25701RD

Wooden

CS25701WNNR	85381010	1 Module Plate	194	10	
CS25702WNNR	85381010	2 Module Plate			
CS25703WNNR	85381010	3 Module Plate	247		
CS25704WNNR	85381010	4 Module Plate	268		
CS25705WNNR	85381010	5 Module Plate (Compatible With 4M Metal Box)			
CS25706WNNR	85381010	6 Module Plate	342		
CS25707WNNR	85381010	8 Module Horizontal	491		
CS25709WNNR	85381010	8 Module Plate Horizontal (Compatible with 6M Metal Box)			
CS25710WNNR	85381010	10 Module-Vertical (Compatible With 8M (4+4) Metal Box)	491		5
CS25711WNNR	85381010	10 Module-Horizontal (Compatible With 8M (H) Metal Box)	491		10
CS25712WNNR	85381010	12 Module Plate	604	5	
CS25716WNNR	85381010	16 Module Plate (Compatible With 12M Metal Box)	639		
CS25718WNNR	85381010	18Module Plate	759		

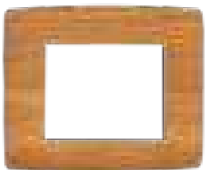

Cover Plate Sizes (All dimensions in mm)

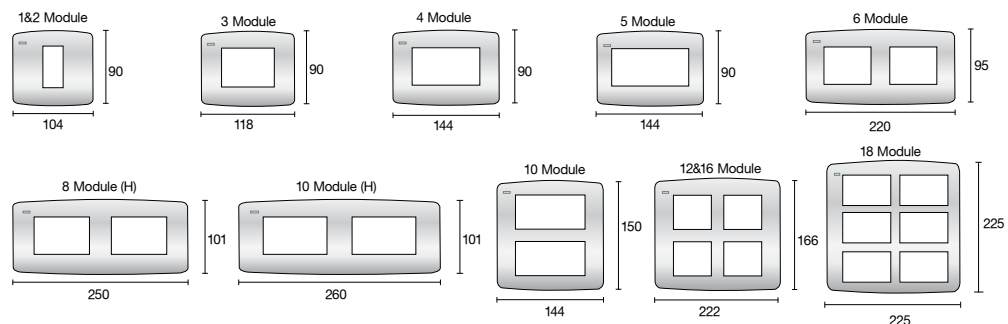



DESIGNED FOR SEAMLESSLY BLEND STYLE & AFFORDABILITY



anywhere, everywhere...



FLAME
RETARDANT



SLEEK
DESIGN



UNBREAKABLE
DESIGNS



SMOOTH
TO TOUCH



Switches



CB20568NR CB20571NR CB20580NR



CB20569NR CB20569NR CB20508NR

Product Code	HSN Code	Description	Rating	No. Modules	MRP (₹)	Std. Pkg. (Nos.)
CB20568NR	85361010	Switch 10AX 1way	10AX	1M	72	20
CB20571NR	85361010	Switch 10AX 2way	10AX	1M	93	20
CB20569NR	85361010	Switch Indicator 10AX 1 Way	10AX	1M	94	20
CB20509NR	85361010	Bell Push 10A	10A	1M	83	20
CB20508NR	85361010	Bell Push 10A Indicator	10A	1M	94	20
CB20511NR	85361010	Bell Push 10A Indicator	10A	2M	133	10
CB20580NR	85361020	Switch 20A	20A	1M	89	20
CB20584NR	85361020	Switch Indicator 20A	20A	1M	108	20
CB20121NR	85361020	Switch 32A DP 1 Way Indicator	32A	2M	283	10
CB20581NR	85361020	Switch 20A 2way	20A	1M	106	20

Sockets / Fan Regulator / Dimmer



CB20370NR CB20354NR



CB20827NR CB20826NR

Product Code	HSN Code	Description	Rating	No. Modules	MRP (₹)	Std. Pkg. (Nos.)
CB20370NR	85361010	Socket 6A 3 Pin	6A	2M	83	10
CB20354NR	85361020	Twin Socket 6/16A	6/16A	2M	175	10
CB20827NR	85361010	Fan Regulator 80W	80W	1M	260	20
CB20826NR	85361010	Fan Regulator 100W	100W	2M	340	10
CB20804NR	85361010	Tiny Dimmer 300W	300W	1M	260	20

Accessories



CB20056NR CB20631NR CB20228NR



CB20251NR CB20272NR CB20633NR

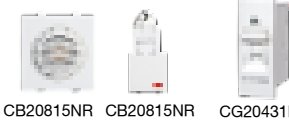

CB20815NR CB20815NR CG20431R

Product Code	HSN Code	Description	Rating	No. Modules	MRP (₹)	Std. Pkg. (Nos.)
CB20056NR	85361010	Blank Plate	-	1M	22	20
CB20631NR	85361010	Phase Indicator LED Red	-	1M	70	20
CB20228NR	85361010	TV Socket outlet	-	1M	92	20
CB20251NR	85361010	RJ11 Tel Jack with Shutter	-	1M	92	20
CB20272NR	85361010	RJ45 Computer Jack Cat6	-	1M	550	20
CB20633NR	94051090	Foot Light LED Cool day Light	-	2M	295	10
CB20636NR	85361010	Electronic Buzzer Parrot	-	2M	380	10
CB20815NR	85361020	Key Tag Switch 32A	32A	2M	522	5
CG20431R-437RNR	85361010	Single Pole Tripping Curve 'C' 4.5kA	6A-32A	1M	235	12
CG20438R-443RNR	85361010	Double Pole Tripping Curve 'C' 4.5kA	6A-32A	2M	560	6

Cover Plate with Support Plate



CB25804WHNR

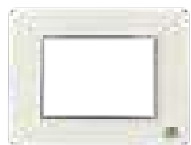

CB25804CNR

Product Code	HSN Code	Description	No. Modules	MRP (₹)	Std. Pkg. (Nos.)
CB25801WHNR	85381010	1 Module White	1M	80	10
CB25802WHNR	85381010	2 Module White	2M	80	10
CB25803WHNR	85381010	3 Module White	3M	94	10
CB25804WHNR	85381010	4 Module White	4M	110	10
CB25806WHNR	85381010	6 Module White	6M	155	10
CB25808WHNR	85381010	8 Module White - Horizontal	8M	185	10
CB25809WHNR	85381010	8 Module White - Vertical	8M	185	10
CB25812WHNR	85381010	12 Module White	12M	239	10
CB25816WHNR	85381010	16 Module White	16M	250	5
CB25818WHNR	85381010	18 Module White	18M	283	5
CB25801CNR	85381010	1 Module White with Chrome	1M	85	10
CB25802CNR	85381010	2 Module White with Chrome	2M	85	10
CB25803CNR	85381010	3 Module White with Chrome	3M	95	10
CB25804CNR	85381010	4 Module White with Chrome	4M	120	10
CB25806CNR	85381010	6 Module White with Chrome	6M	160	10
CB25808CNR	85381010	8 Module White with Chrome - Horizontal	8M	190	10
CB25809CNR	85381010	8 Module White with Chrome - Vertical	8M	190	10
CB25812CNR	85381010	12 Module White with Chrome	12M	255	10
CB25816CNR	85381010	16 Module White with Chrome	16M	272	5
CB25818CNR	85381010	18 Module White with Chrome	18M	335	5



WiNtrip 'S'

Single Lock Modular MCB

The perfect solution for AC's, Refrigerators & Electrical Appliances

Safe | Convenient | Energy Saving | Wide Range
Compact Design | Overload & Short Circuit Protection
Rapid Closing Mechanism | Easy to Operate

Product Code	HSN Code	Description	No. of Modules	MRP (₹)	Std. Pkg. (Nos.)
--------------	----------	-------------	----------------	---------	------------------

Single Pole - Tripping Curve 'C'

CG20431RNR	85361010	6A Single Pole 4.5kA-Tripping Curve 'C'	1	235	12
CG20432RNR	85361010	10A Single Pole 4.5kA-Tripping Curve 'C'			
CG20433RNR	85361020	16A Single Pole 4.5kA-Tripping Curve 'C'			
CG20437RNR	85361020	20A Single Pole 4.5kA-Tripping Curve 'C'			
CG20435RNR	85361020	25A Single Pole 4.5kA-Tripping Curve 'C'			
CG20436RNR	85361020	32A Single Pole 4.5kA-Tripping Curve 'C'			



CS20431RNR

Double Pole - Tripping Curve 'C'

CG20438RNR	85361010	6A Double Pole 4.5kA-Tripping Curve 'C'	2	560	6
CG20439RNR	85361010	10A Double Pole 4.5kA-Tripping Curve 'C'			
CG20440RNR	85361020	16A Double Pole 4.5kA-Tripping Curve 'C'			
CG20441RNR	85361020	20A Double Pole 4.5kA-Tripping Curve 'C'			
CG20442RNR	85361020	25A Double Pole 4.5kA-Tripping Curve 'C'			
CG20443RNR	85361020	32A Double Pole 4.5kA-Tripping Curve 'C'			



CS20443RNR

Non-Modular Miniature Case Circuit Breaker - WiNtrip 'S'

Product Code - Pure White	HSN Code	Description	No. of Modules	MRP (₹)	Std. Pkg. (Nos.)
---------------------------	----------	-------------	----------------	---------	------------------

Single & Double Pole

CS20431NNR	85361010	6A Single Pole 4.5kA-Tripping Curve 'C'	1	235	12
CS20432NNR	85361010	10A Single Pole 4.5kA-Tripping Curve 'C'			
CS20433NNR	85361020	16A Single Pole 4.5kA-Tripping Curve 'C'			
CS20437NNR	85361020	20A Single Pole 4.5kA-Tripping Curve 'C'			
CS20435NNR	85361020	25A Single Pole 4.5kA-Tripping Curve 'C'			
CS20436NNR	85361020	32A Single Pole 4.5kA-Tripping Curve 'C'			
CS20438NNR	85361010	6A Double Pole 4.5kA-Tripping Curve 'C'	2	560	6
CS20439NNR	85361010	10A Double Pole 4.5kA-Tripping Curve 'C'			
CS20440NNR	85361020	16A Double Pole 4.5kA-Tripping Curve 'C'			
CS20441NNR	85361020	20A Double Pole 4.5kA-Tripping Curve 'C'			
CS20442NNR	85361020	25A Double Pole 4.5kA-Tripping Curve 'C'			
CS20443NNR	85361020	32A Double Pole 4.5kA-Tripping Curve 'C'			

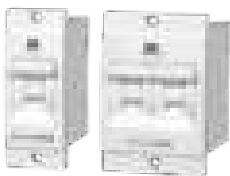

CS20436NR

CS20438NR

Wiring Accessories

General Terms & Conditions

Price are subject to revision without prior notice and will be applicable as prevailing at the time of dispatch.

- This Pricelist supercedes all previous Price Lists.
- Maximum Retail Price (MRP) mentioned are maximum recommended selling prices inclusive of GST.
- All Prices are in Indian Rupees.

Warranty

All our listed Electro-mechanical wiring devices carry a warranty, against manufacturing defects for a period of 10 years from the date of invoicing & 2 years for all mains related electronic wiring products viz. Dimmers, Step Fan regulator and Indicators subject to it's usages in normal recommended operating conditions. Guarantee does not include Metal Box, Plug Tops and other stand alone products. The guarantee defines the company's entire liability & does not cover consequences loss or damage or re-installations cost arising from defective product. The company liability shall be limited to exchange or repair of the product, at our discretion, provided that such defective products are returned to nearest Branch office.





TYPE 2 CO-ORDINATION CHART



For Type2 Co-Ordination Chart kindly visit to our website: www.cselectric.co.in

We touch your **electricity** everyday!



CX Partner Program



An-IEC 61439 Design Verified Panel

- Compliance to IEC 61439
- Fixed Construction
- Rated Voltage: 415V AC
- Internal Arc Protected Design (IEC 61641)
- From 3B Type-2-4B Type-7 Construction
- Seismic Zone: 4



Modernization Solution

LV Switchgear

Comprehensive Service Support

With over five decades of experience, C&S Electric is a trusted after-sales service expert for Low Voltage Distribution Applications in Power Generation Plant, Oil Sector, Industries and Residential & Commercial Complexes. We offer the following services to support you in maintaining your Low Voltage Distribution System:

Toll Free Number

1800 572 2012

WhatsApp No. / 99994 43333

Email: customerservice@cselct.com

Regular Maintenance Support

We ensure that your systems receive routine upkeep to keep them running smoothly.

Preventive Maintenance Program

Our proactive approach allows us to identify and address potential issues before they become major problems.

On Call Assistance Program

Whenever you need assistance, we are just a call away to provide prompt support.

Annual Maintenance Contract

Benefit from a comprehensive maintenance agreement for added convenience and peace of mind.

Product Support for Managing

Obsolescence, Retrofitting & Upgradation

We help you manage outdated equipment by offering support for retrofitting and upgrading your switchgear products.

Availability of Spares

Whenever you need any spares for switchboard or switchgear, we are always available.

Trust on **C&S Electric** as your reliable partner in maintaining the performance and longevity of your Low Voltage Distribution systems.



Our service philosophy:

Customer's systems should be up & running. Insurgencies can follow.



We touch your electricity everyday!



TRAINING

AUTOMATION

SKILL

DEVELOP

ARYABHATTA Training Center

Embark on a transformative journey with C&S
Switchgear Training Program

Maximize productivity, conserve energy, minimize operational costs, and enhance safety with our comprehensive C&S Electrical & Automation training programs.

With a proven track record of benefiting over more than 2000+ professionals in the last 5 years, our training programs provide the right exposure and impart knowledge on the selection, installation, maintenance, and testing of electrical & automation products.



Accelerate your technical expertise and go above and beyond with

- 12 Courses on contemporary topics designed to keep you at the forefront of the industry.
- Courses applicable to all switchgear brands, ensuring you can apply your knowledge universally.
- Conveniently located Training Center in Noida (UP), providing easy access to quality education.
- A blend of theory and practical experience, equipping you with the skills needed for real-world applications.

Our training programs cover a wide range of topics to meet your specific needs, including:

- Low Voltage Switchgear, Switchboard & Medium Voltage Switchgear protection relays, enabling you to master the complexities of electrical distribution systems.
- Switchboard Electrical Design, equipping you with the knowledge to create efficient and safe electrical installations.
- Protective Relays & Earthing, ensuring the safety and reliability of electrical systems.
- Power Quality Solutions, addressing challenges related to voltage fluctuations, harmonics, and more.



We touch your electricity everyday!

C&S Electric is committed to create a unique alchemy of outstanding products, operational excellence, path breaking customer services & compelling marketing. Further to enhance the post sales customer service experience, C&S introduces a service monitoring software "Salesforce". The software provides a transparent service tracking system and helps in efficient monitoring and quick resolution of queries.



Key Features & Benefits

- Transparent process
- Efficient monitoring & tracking of each Service Request
- Quick resolution time
- All relevant customer data in one single location
- Improved customer relationships
- Strengthen C&S brand image & reputation in the market

FOR QUICK ENQUIRY

Toll Free Number: 1800 572 2012



95994 45253
(9:00 AM to 6:00 PM)

Email: customercare@cselectric.co.in

Escalation Matrix

***C&S Branch Service Engineer " ≥ 24 Hours"**
(Refer contact details on page no. 5 to 11)

***Central Customer Services (CCS) " ≥ 48 Hours"**
(Connect via Toll free no., Email ID, & Whatsapp no.)

Dy. Manager - Mr. Praveen Chauhan " ≥ 72 Hours"
Email: praveen.chauhan@cselectric.co.in

Head Services - Mr. Bikram Rana " ≥ 96 Hours"
Email: bikram.rana@cselectric.co.in

Sr.VP - Mr. P. Anandan " ≥ 120 Hours"
Email: anandan.p@cselectric.co.in



*Refer complete service directory for contact details of service team



Marketing offices spread all over India

REGISTERED OFFICE

210, 211 & 212, Second Floor, 'Salcon Aurum' Building
Plot No. 4, Jasola District Centre, New Delhi - 110 025 (INDIA)
Tel.: +91 11 6922 5600 | Email: info@cselectric.co.in

CENTRAL MARKETING OFFICE

C-60, Wing-A, Phase-II, Noida, District Gautam Budh Nagar, Uttar Pradesh - 201 305 (INDIA)
Tel.: +91 120 387 4800 / 01 | Email: cmo@cselectric.co.in

CUSTOMER CARE

Toll Free Number: 1800 572 2012 | Email: customercare@cselectric.co.in

NORTHERN REGION

DELHI
Email: cmo@cselectric.co.in

LUDHIANA
Email: ludhiana@cselectric.co.in

LUCKNOW
Email: lucknow@cselectric.co.in

KANPUR
Email: lucknow@cselectric.co.in

JAIPUR
Email: jaipur@cselectric.co.in

CENTRAL REGION

INDORE
Email: indore@cselectric.co.in

RAIPUR
Email: raipur@cselectric.co.in

NAGPUR
Email: nagpur@cselectric.co.in

EASTERN REGION

KOLKATA
Email: kolkata@cselectric.co.in

GUWAHATI
Email: guwahati@cselectric.co.in

RANCHI
Email: ranchi@cselectric.co.in

BHUBANESWAR
Email: bhubaneshwar@cselectric.co.in

WESTERN REGION
MUMBAI
Email: mumbai@cselectric.co.in

PUNE
Email: pune@cselectric.co.in

AHMEDABAD
Email: ahmedabad@cselectric.co.in

RAJKOT
Email: ahmedabad@cselectric.co.in

BARODA
Email: baroda@cselectric.co.in

SURAT
Email: surat@cselectric.co.in

SOUTHERN REGION
CHENNAI
Email: chennai@cselectric.co.in

COIMBATORE
Email: coimbatore@cselectric.co.in

KOCHI
Email: cochin@cselectric.co.in

MADURAI
Email: commercial.madurai@cselectric.co.in

BENGALURU
Email: bangalore@cselectric.co.in

HYDERABAD
Email: hyderabad@cselectric.co.in

VIJAYAWADA
Email: vijayawada@cselectric.co.in

RESIDENT ENGINEERS

AHMEDABAD: Visnagar **BANGALORE:** Bellary, Hassan, Hubli, Mangalore **BARODA:** Anand, Vapi **BHUBANESWAR:** Behrampur, Cuttack, Rourkela, Sambalpur **CHENNAI:** Vellore, Trichy **KOCHI:** Kollam **COIMBATORE:** Erode **DELHI & HARYANA:** Gurugram, Hissar, Panipat, **UP (W) & UK:** Agra, Bareilly, Dehradun, Ghaziabad, Meerut, Moradabad, Noida **GUWAHATI:** Silchar, Tezpur **HYDERABAD:** Karimnagar, Warangal **INDORE:** Bhopal, Gwalior, Jabalpur, Rewa, Ujjain **J&K:** Kashmir, Srinagar **JAIPUR:** Bhilwara, Bikaner, Jodhpur, Kota, Sikar, Udaipur **KOLKATA:** Bankura, Bardhaman, Siliguri **LUCKNOW:** Gorakhpur, Prayagraj, Shahjhanpur, Varanasi **LUDHIANA:** Amritsar, Barnala, Jammu, Mansa **MADURAI:** Nagercoil, Rajapalayam **MUMBAI:** Aurangabad, Nasik **NAGPUR:** Akola, Amravati, Chandrapur **PUNE:** Goa, Nasik, Kolhapur, Sangali, Solapur **RAIPUR:** Ambikapur **RAJKOT:** Bhavnagar, Jamnagar **RANCHI:** Dhanbad, Muzaffarpur, Patna, Purnia, Siwan **SURAT:** Aurangabad, Nasik **VIJAYAWADA:** Chittoor, Rajahmundry, Tirupathi, Vishakhapatnam

WAREHOUSES

National Warehouse

NOIDA B-58, Sector-80, Phase-II, Noida, District Gautam Budh Nagar, Uttar Pradesh - 201305 INDIA
Ph.: +91 120 3857483/84/88/89

JHAJJAR P-12, Sector-3, Model Economic Township, Street No. 1, Badli, Dadri Toe
Jhajjar, Haryana - 124103 INDIA

